

- F Notice de montage
- GB Installation instructions
- E Manual de instalación
- I Istruzioni di montaggio
- NL Montage-instructies
- D Montageanleitung



1/2



- Attention aux étapes :
 - GB Check installation steps :
 - Atención a los pasos :
 - Attenzione ai passi :
 - Aandacht voor de stappen :
 - Achtung vor den Schritten :
- P. 4 - 12 - 17

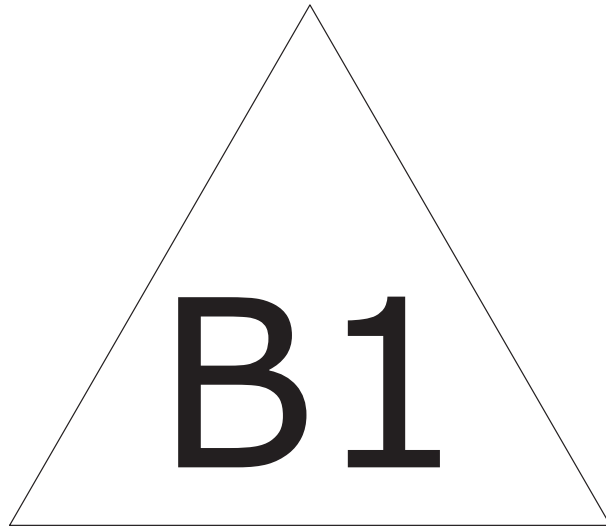

+

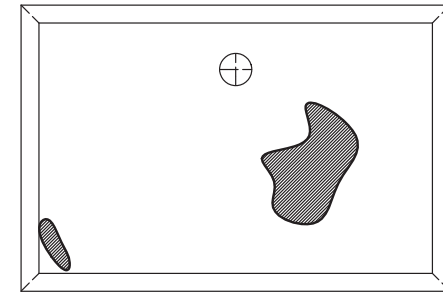

- F** D'éventuelles irrégularités de surface sur le dessous de votre sol n'empêchent pas une installation conforme aux préconisations de pose. La colle (polyuréthane ou MS polymère) comblera facilement ces manques lors du collage.
- GB** Any surface irregularities on the underside of the floor have no influence on the installation according to the installation recommendations. The adhesive (polyurethane or MS polymer) compensates for these unevenness when bonding the feet off without any problems.
- E** Posibles irregularidades de la superficie en la parte inferior del suelo no impida la instalación de acuerdo con las recomendaciones de instalación. El adhesivo (poliuretano o polímero MS) rellenará fácilmente estos huecos al pegar los pies.
- I** Eventuali irregolarità della superficie nella parte sotto del pavimento non impediscono l'installazione in base alle raccomandazioni di montaggio. La colla (poliuretano o MS polimero) riempirà facilmente queste lacuna quando si incollano i piedini.
- NL** Eventuele onregelmatigheden in de vlakke onderzijde van uw vloer vormen geen belemmering voor een installatie conform aan de gestelde richtlijnen. De lijm (polyurethaan of MS-polymeer) vult eventuele openingen makkelijk op tijdens het lijmen.
- D** Eventuelle Unregelmäßigkeiten der Oberfläche an der Unterseite Ihres Bodens haben keinen Einfluss auf die Installation gemäß den Einbauempfehlungen. Der Klebstoff (Polyurethan oder MS-Polymer) gleicht diese Unebenheiten beim Verkleben problemlos aus.



F Aspirer le dessous de votre sol avant la pose

GB Vacuum the bottom of the floor before installation

E Aspirar la parte inferior de su suelo antes de instalarlo



I Aspirare la parte sottostante del pavimento prima dell'installazione

NL Stofzuig de bodem van de vloer voor de installatie

D Saugen Sie den Boden des Bodens vor der Installation ab

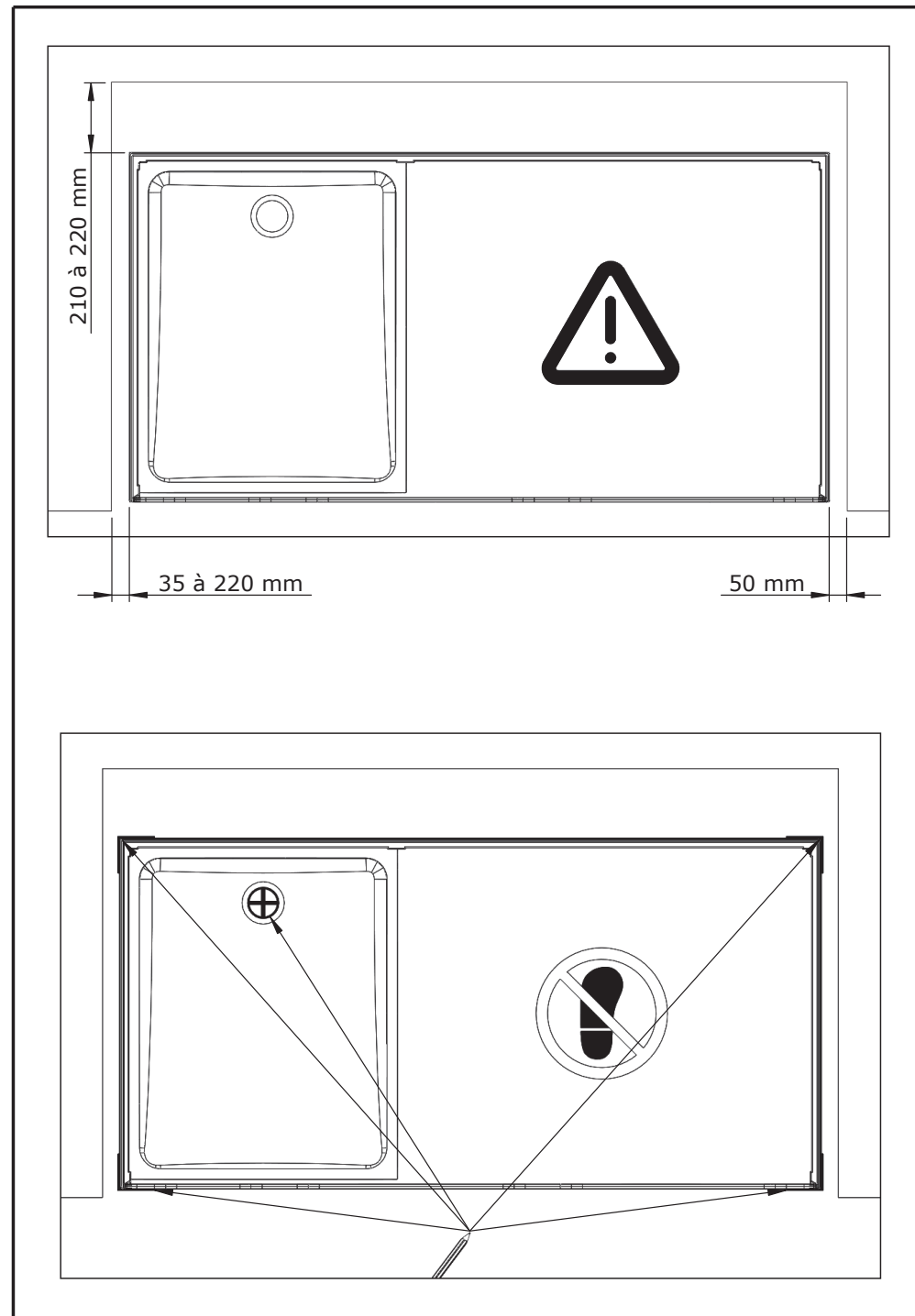
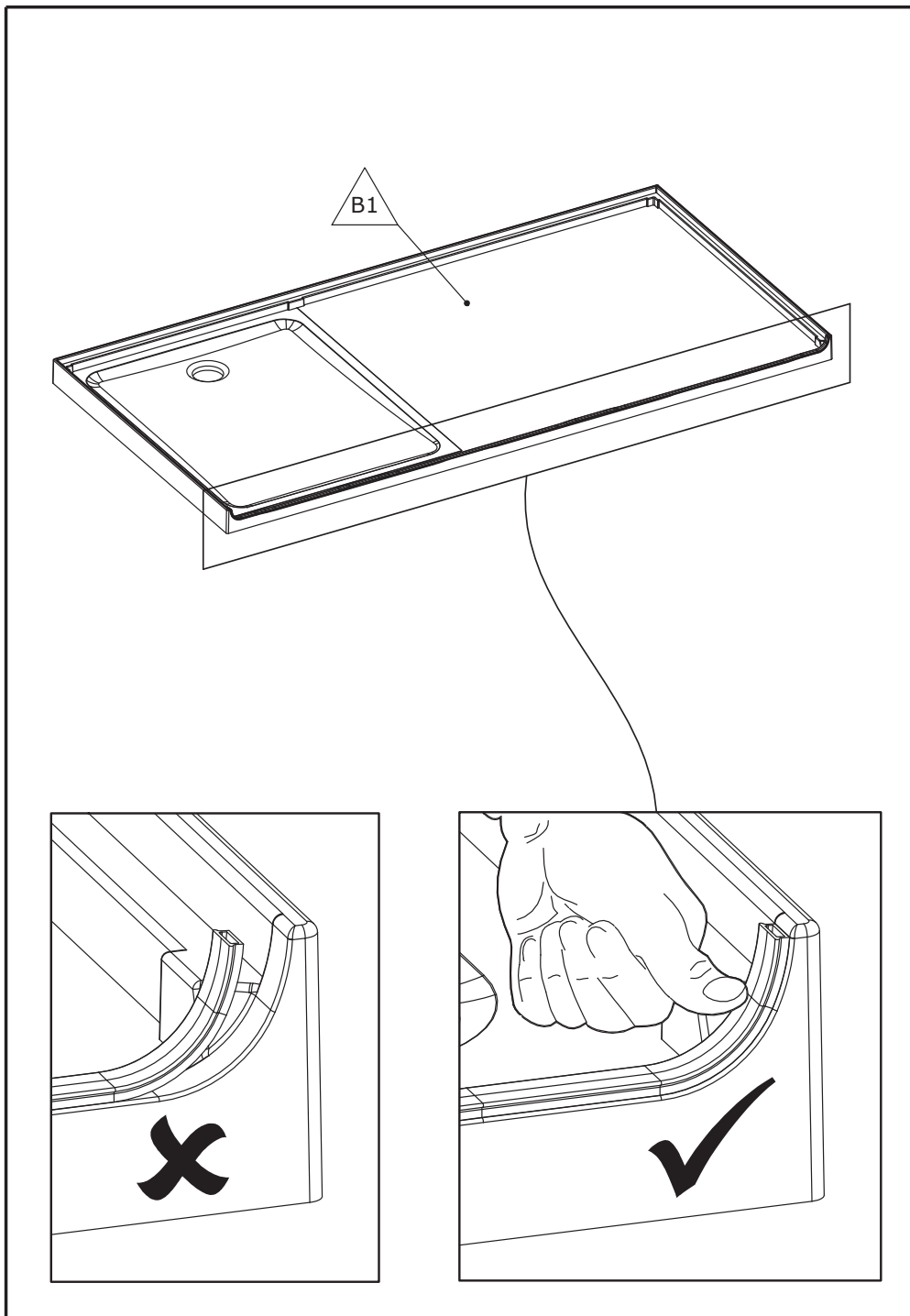

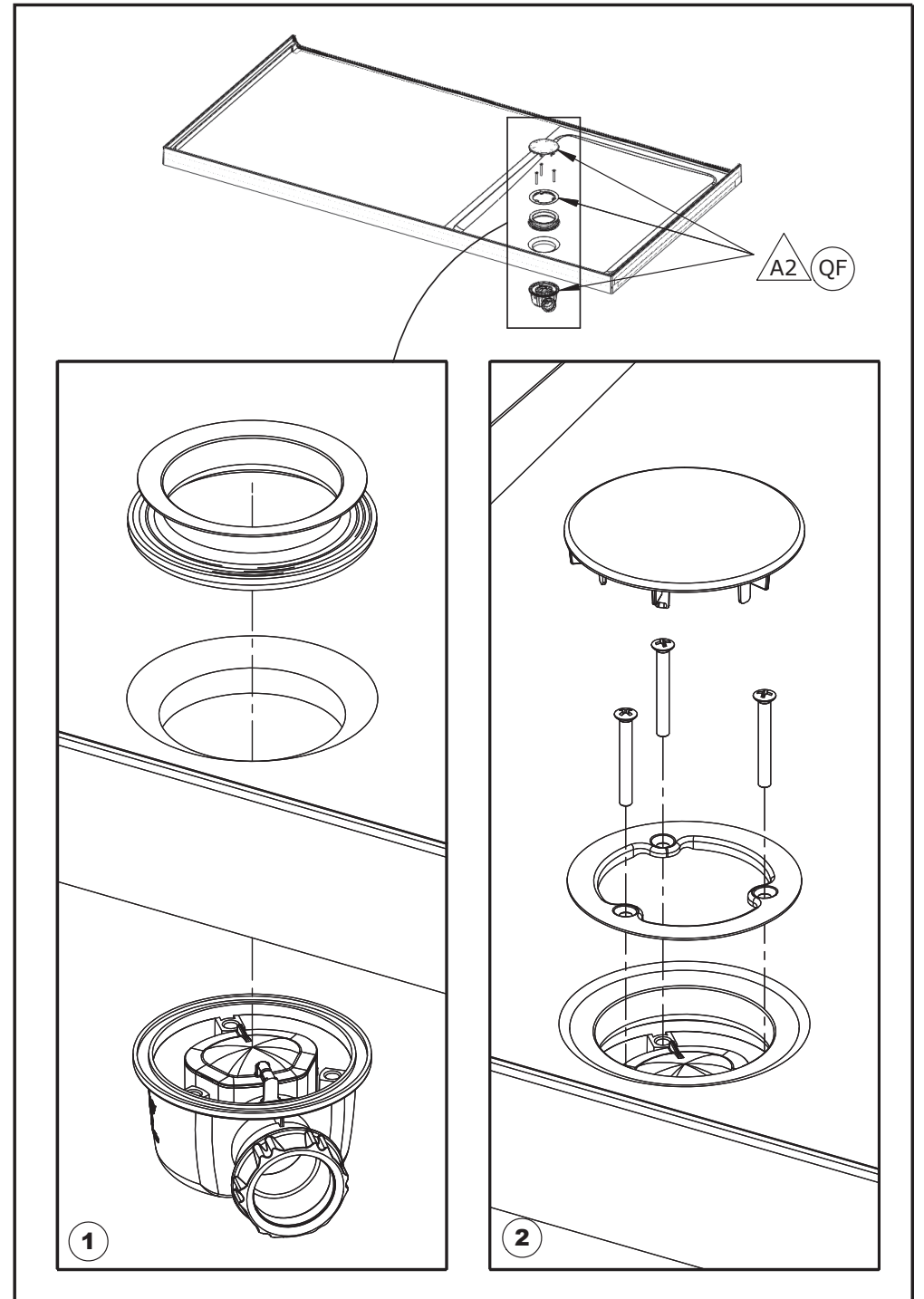
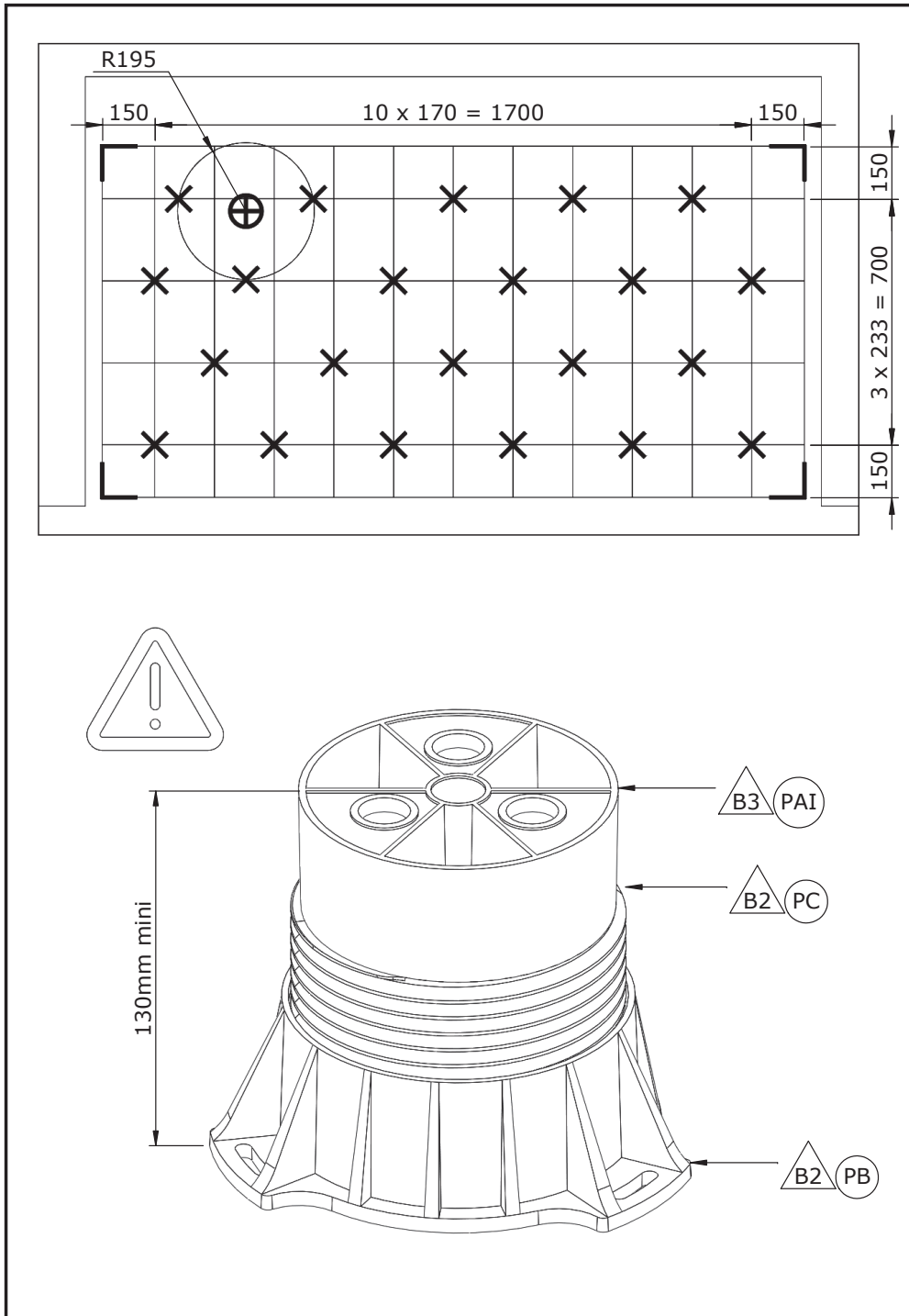

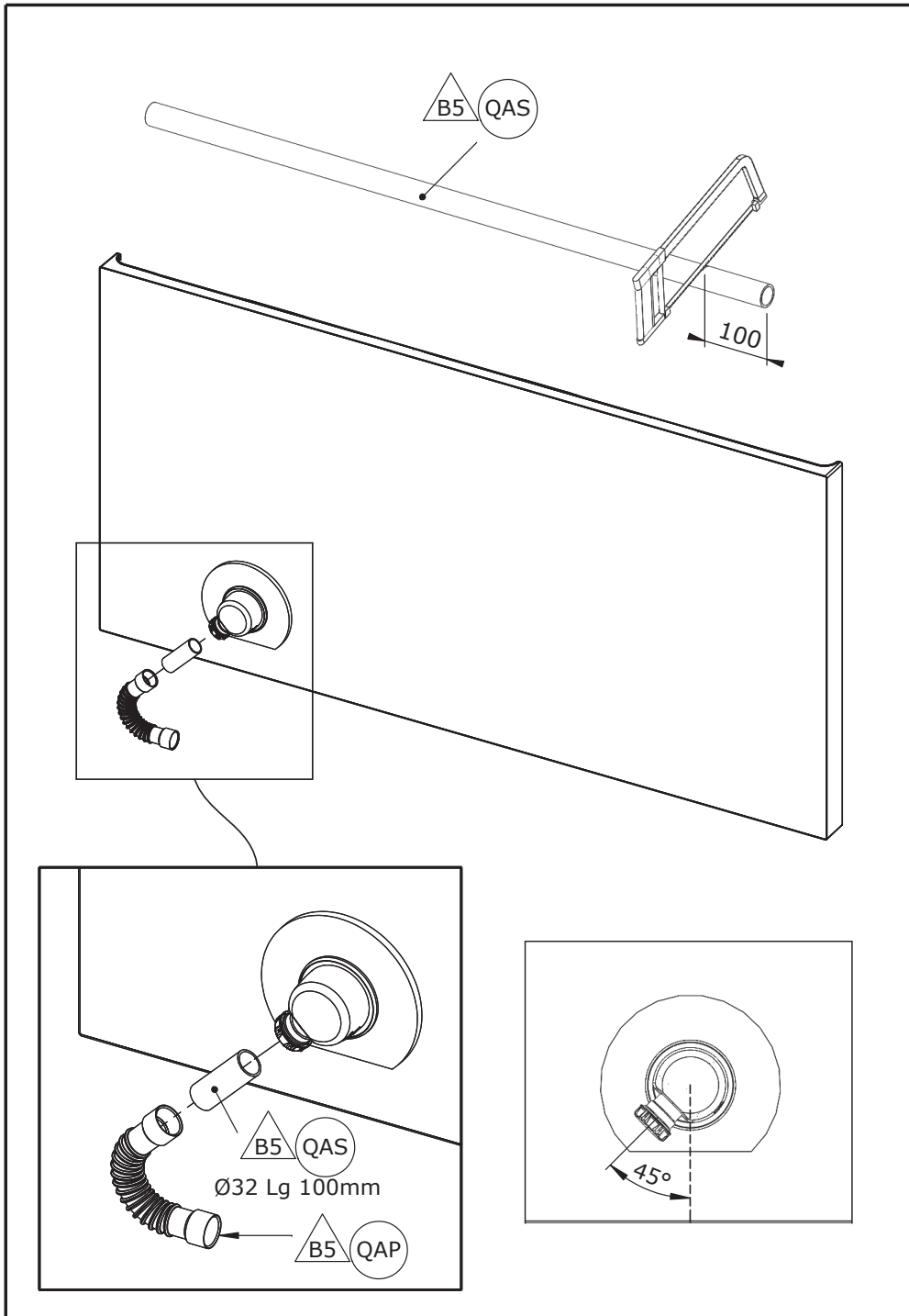

Ⓕ Pose de sol avec pieds Ⓖ Laying the floor with adjustable feet
 Ⓖ Instalación del suelo con pies Ⓕ Posa del pavimento con piedi
 Ⓖ Montage van vloer op poten Ⓕ Installation der Boden mit Füßen

- Ⓕ Colle polyuréthane
- Ⓖ Polyurethane adhesive
- Ⓕ Pegamento de poliuretano
- Ⓕ Adesivo poliuretano
- Ⓖ Polyurethaan kit
- Ⓕ Polyurethan-klebstoff

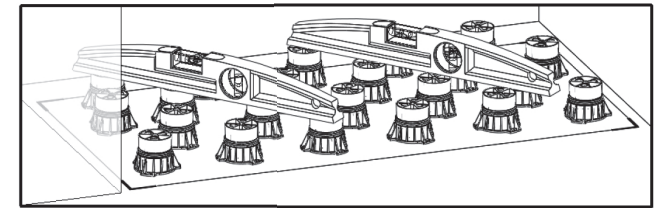
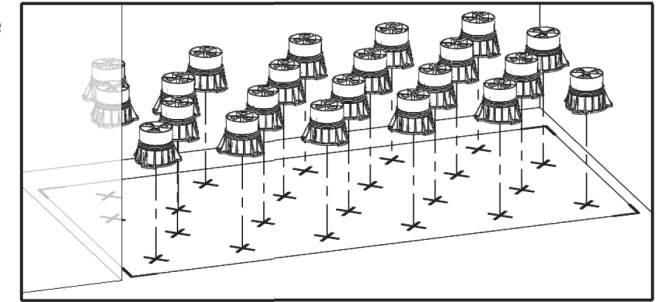
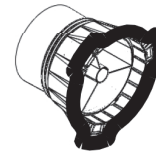
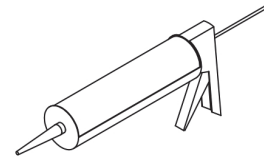

Ⓕ Pose de sol sans pieds Ⓖ Laying the floor without feet
 Ⓖ Instalación del suelo sin pies Ⓕ Posa del pavimento senza piedi
 Ⓖ Montage van vloer zonder poten Ⓕ Installation der Boden ohne Füßen

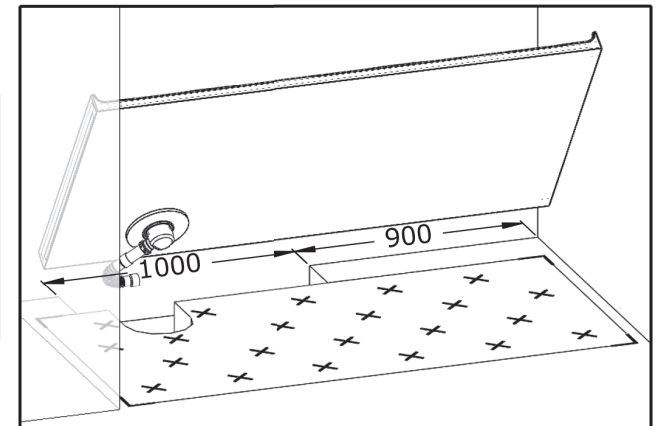
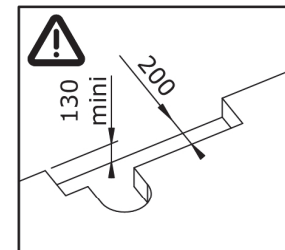

- Ⓕ Colle polyuréthane
- Ⓖ Polyurethane adhesive
- Ⓕ Pegamento de poliuretano
- Ⓕ Adesivo poliuretano
- Ⓖ Polyurethaan kit
- Ⓕ Polyurethan-klebstoff

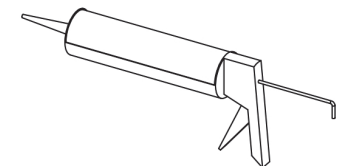

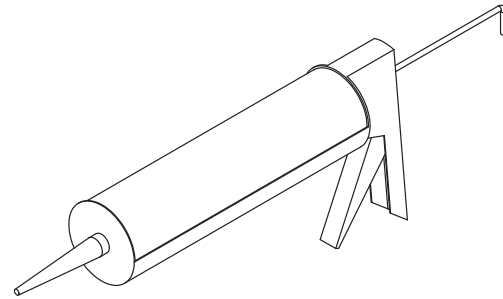
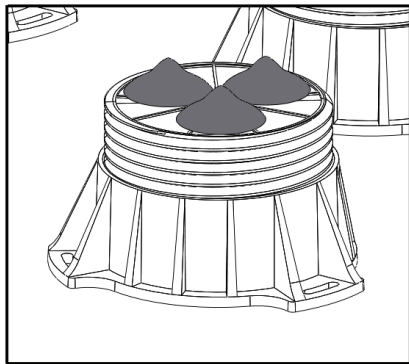

- Colle polyuréthane
- Polyurethane adhesive
- Pegamento de poliuretano
- Adesivo poliuretano
- Polyurethaan kit
- Polyurethan-klebstoff

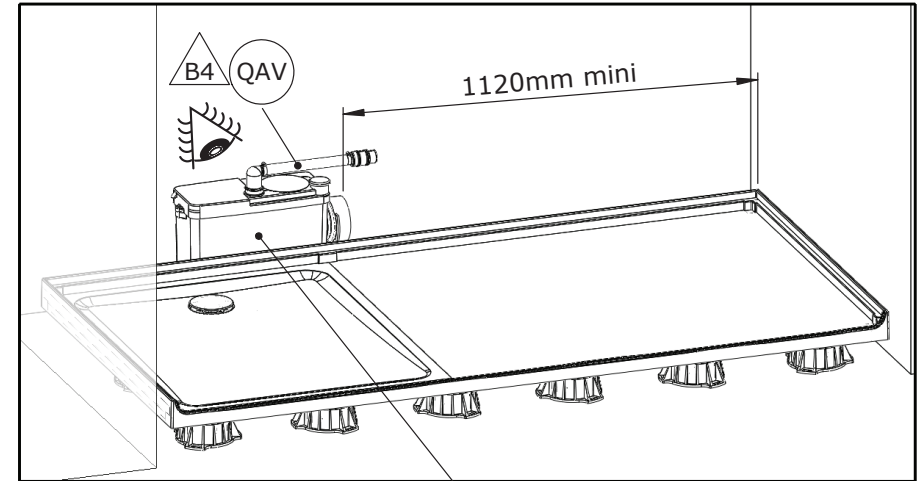
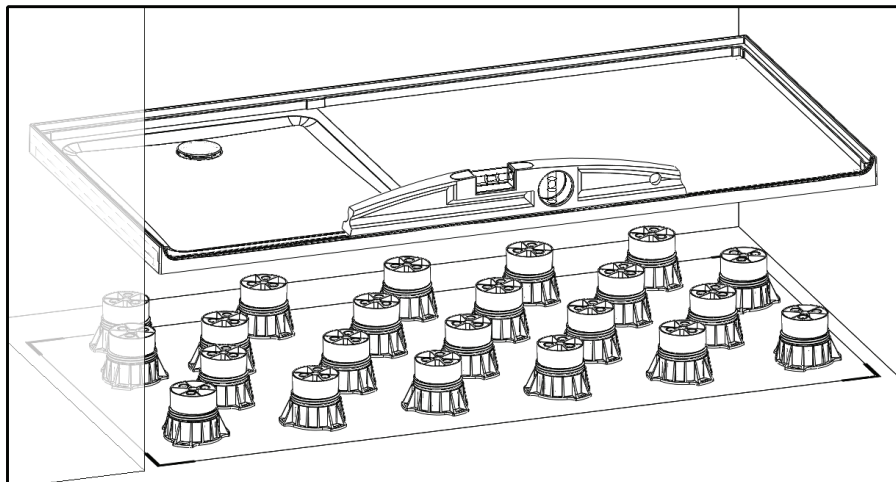

- Raccorder votre évacuation à votre pompe
- Connect your drainage to your pump
- Conecte el drenaje a la bomba
- Collegare l'evacuazione alla pompa
- Sluit de afvoer aan op de pomp
- Abfluss an die Pumpe anschließen

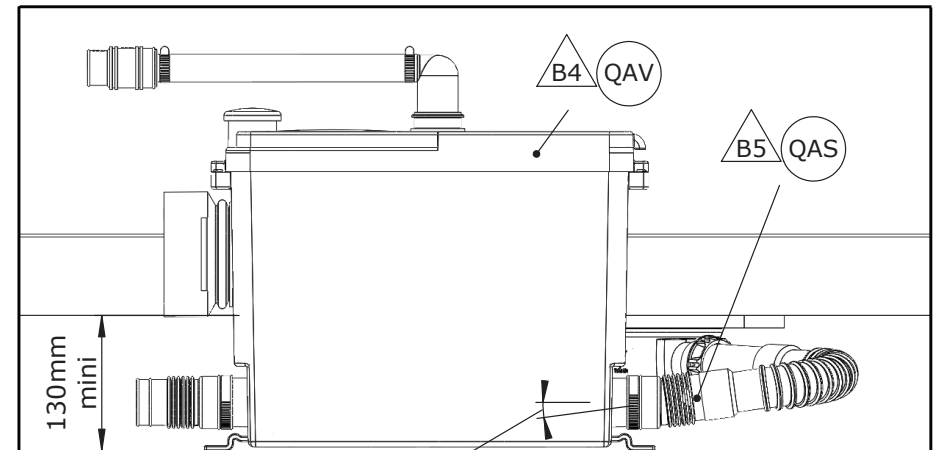

- Pour faciliter l'évacuation, merci de respecter une pente minimum, voir notice concernée
- To facilitate evacuation, please respect a minimum slope, see the relevant instructions
- Para facilitar la evacuación, por favor respete una pendiente mínima, vea las instrucciones correspondientes.
- Per facilitare l'evacuazione, si prega di rispettare una pendenza minima
- Zorg voor een minimale hellingshoek voor een goede afvoer
- Sehen Sie bitte ein minimales Gefälle vor, um den Abfluss zu erleichtern

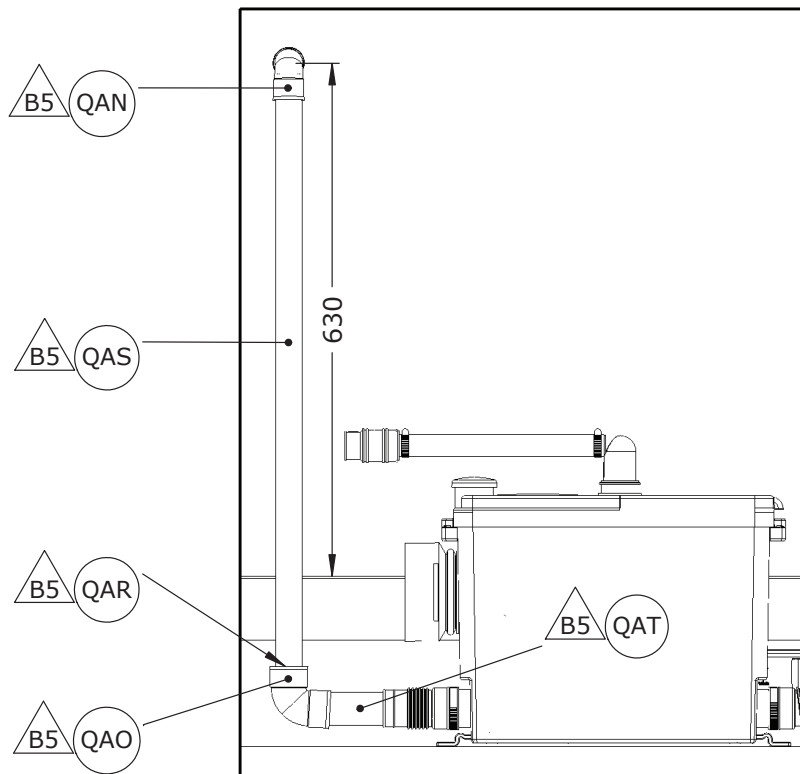
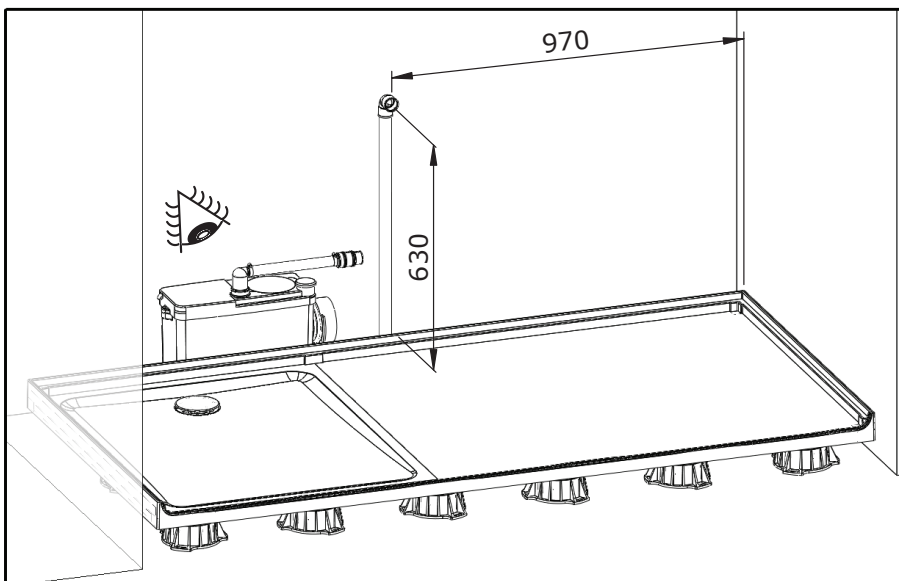

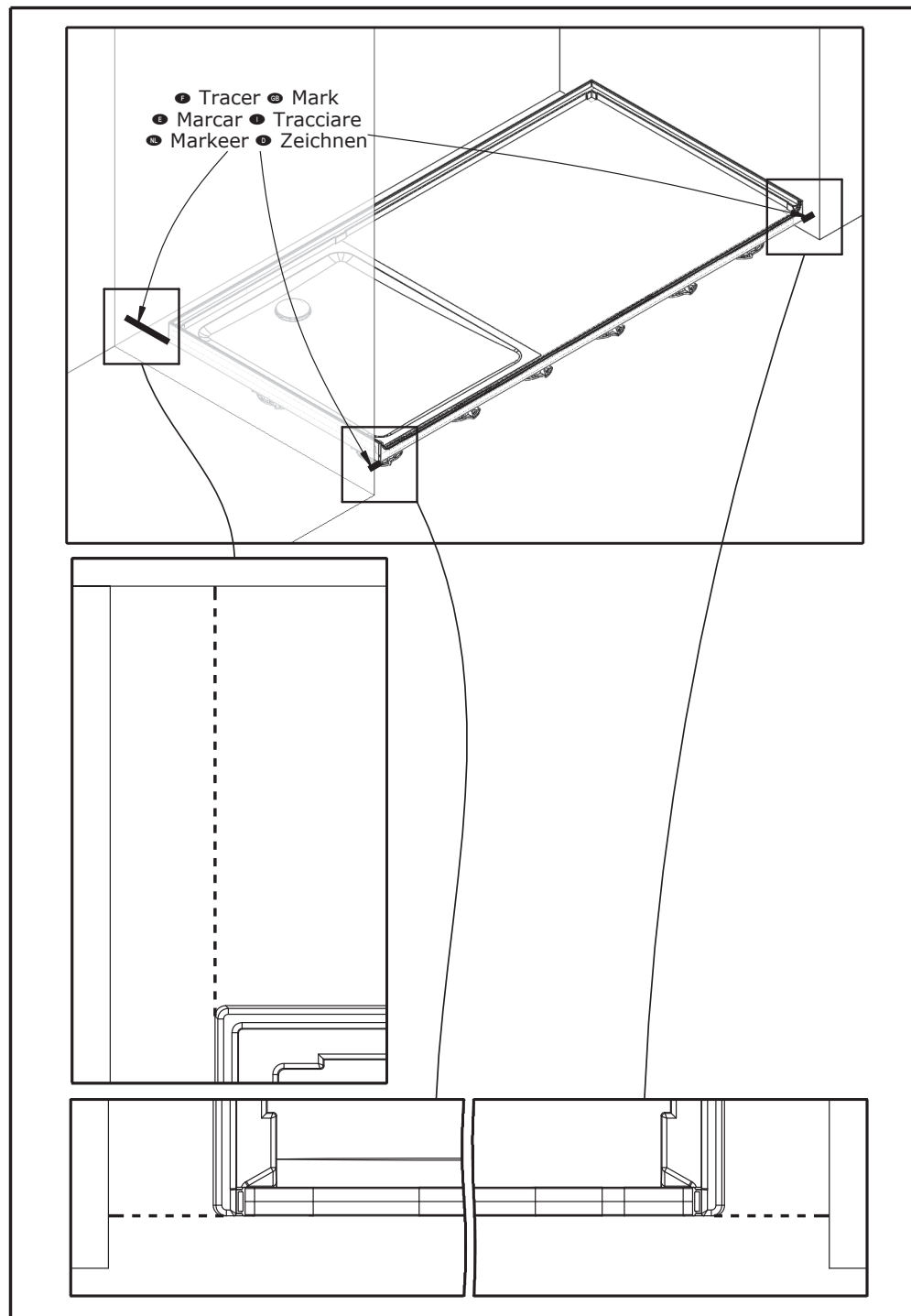
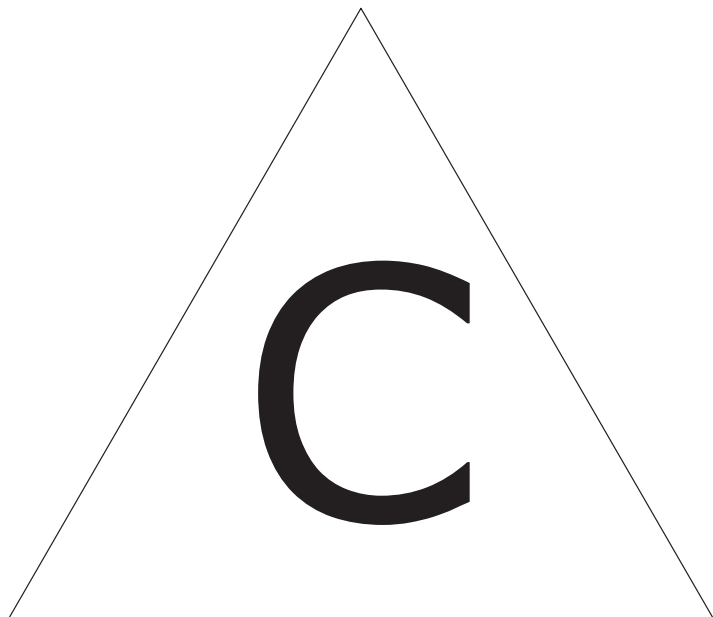

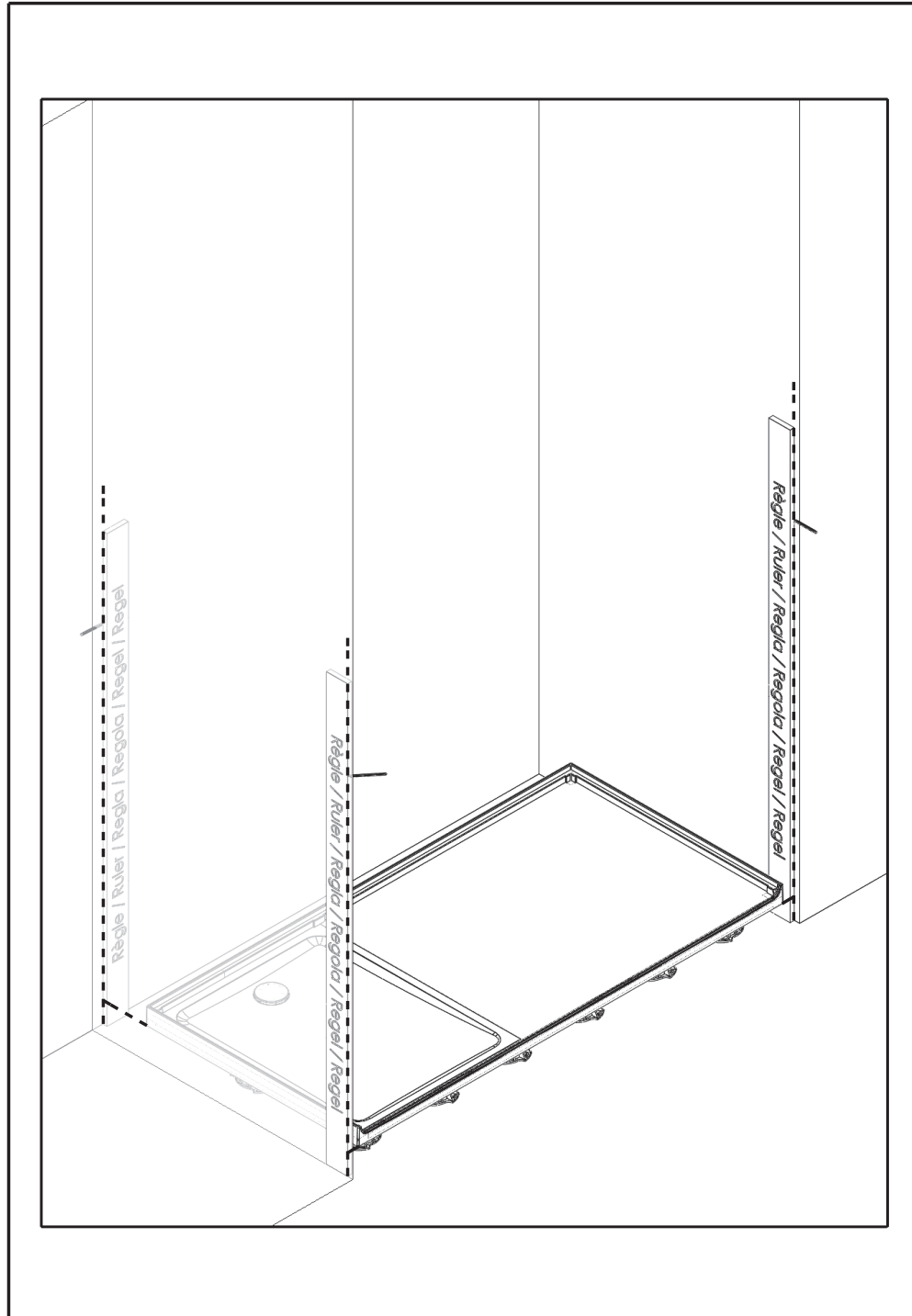
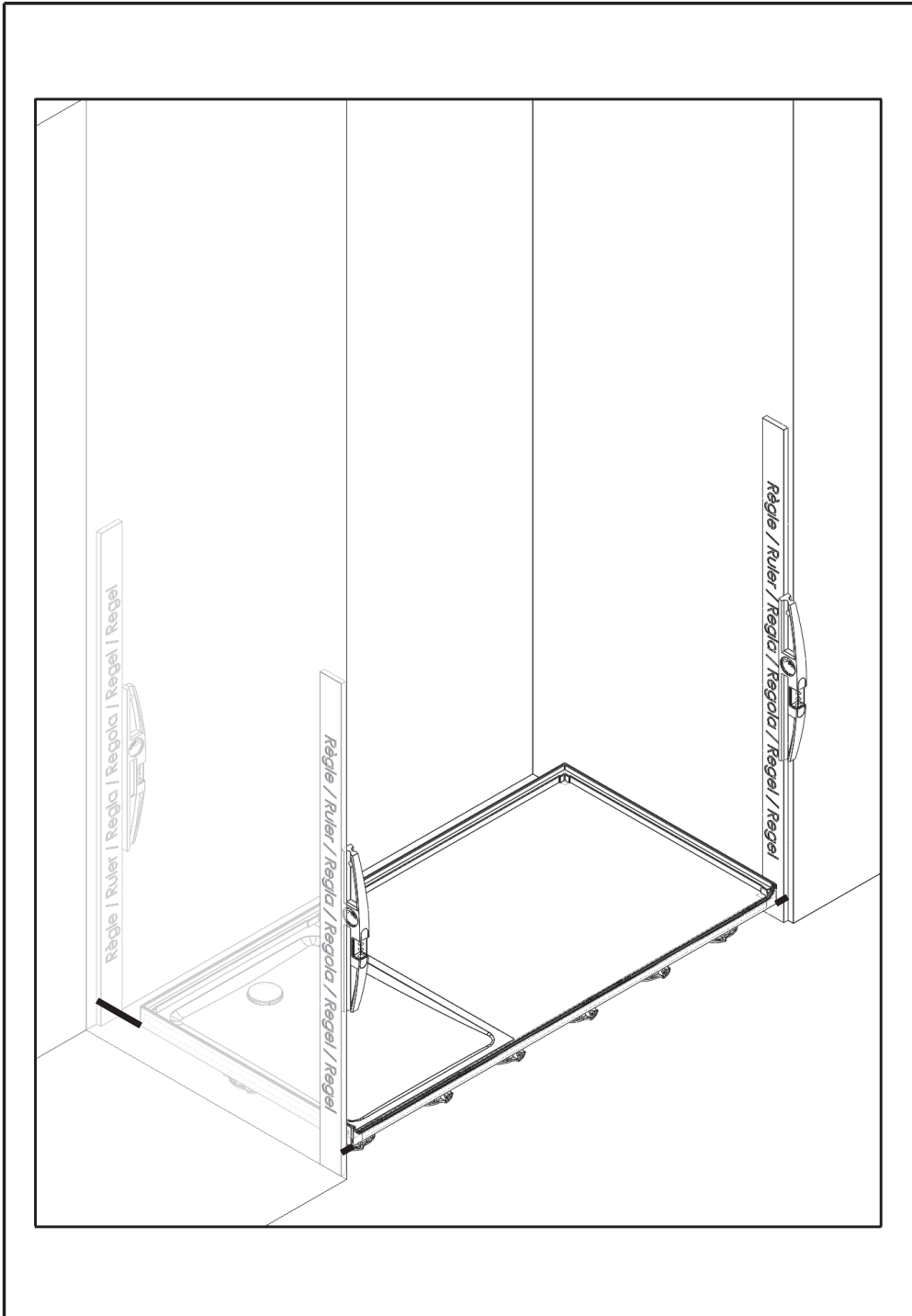

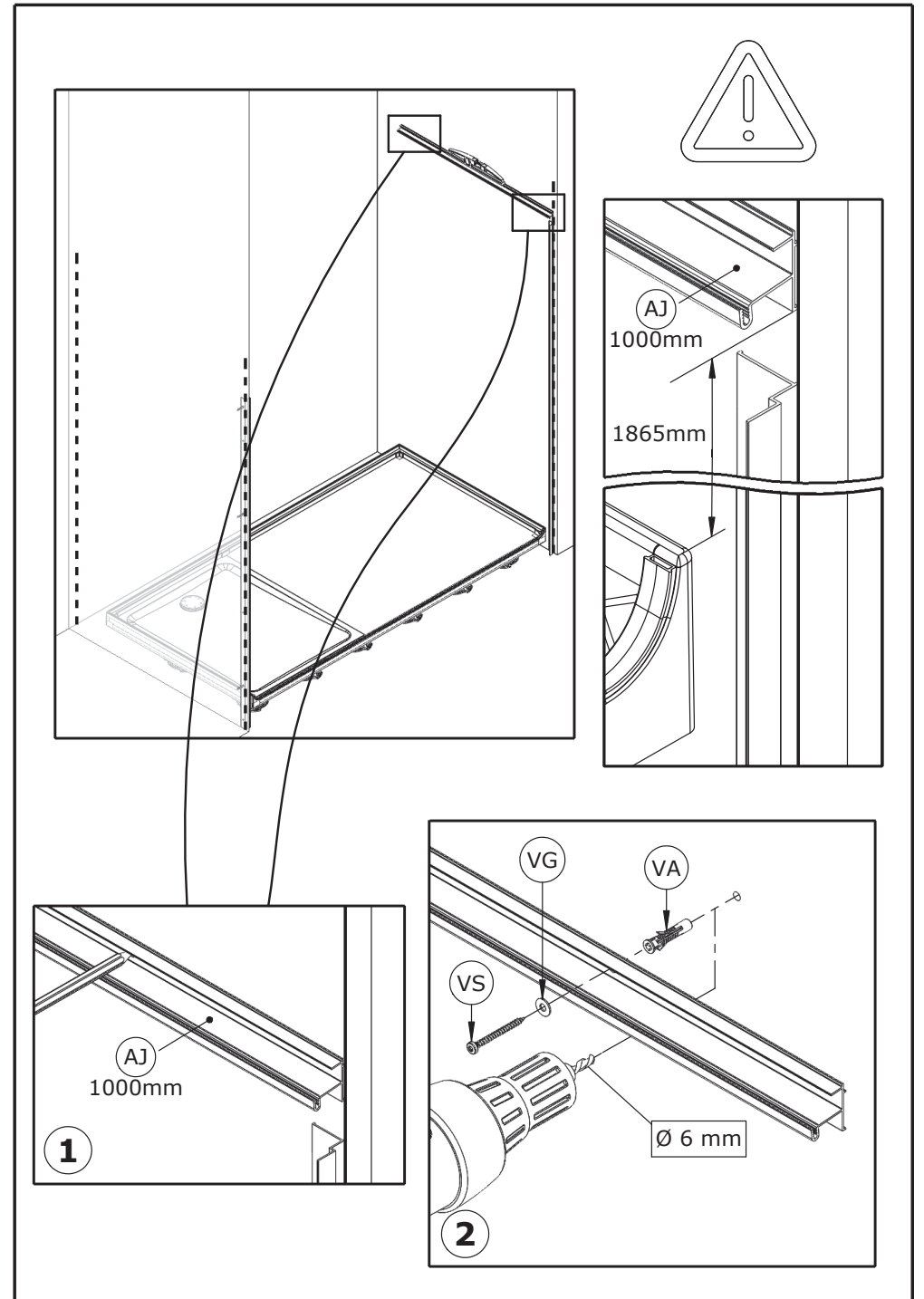
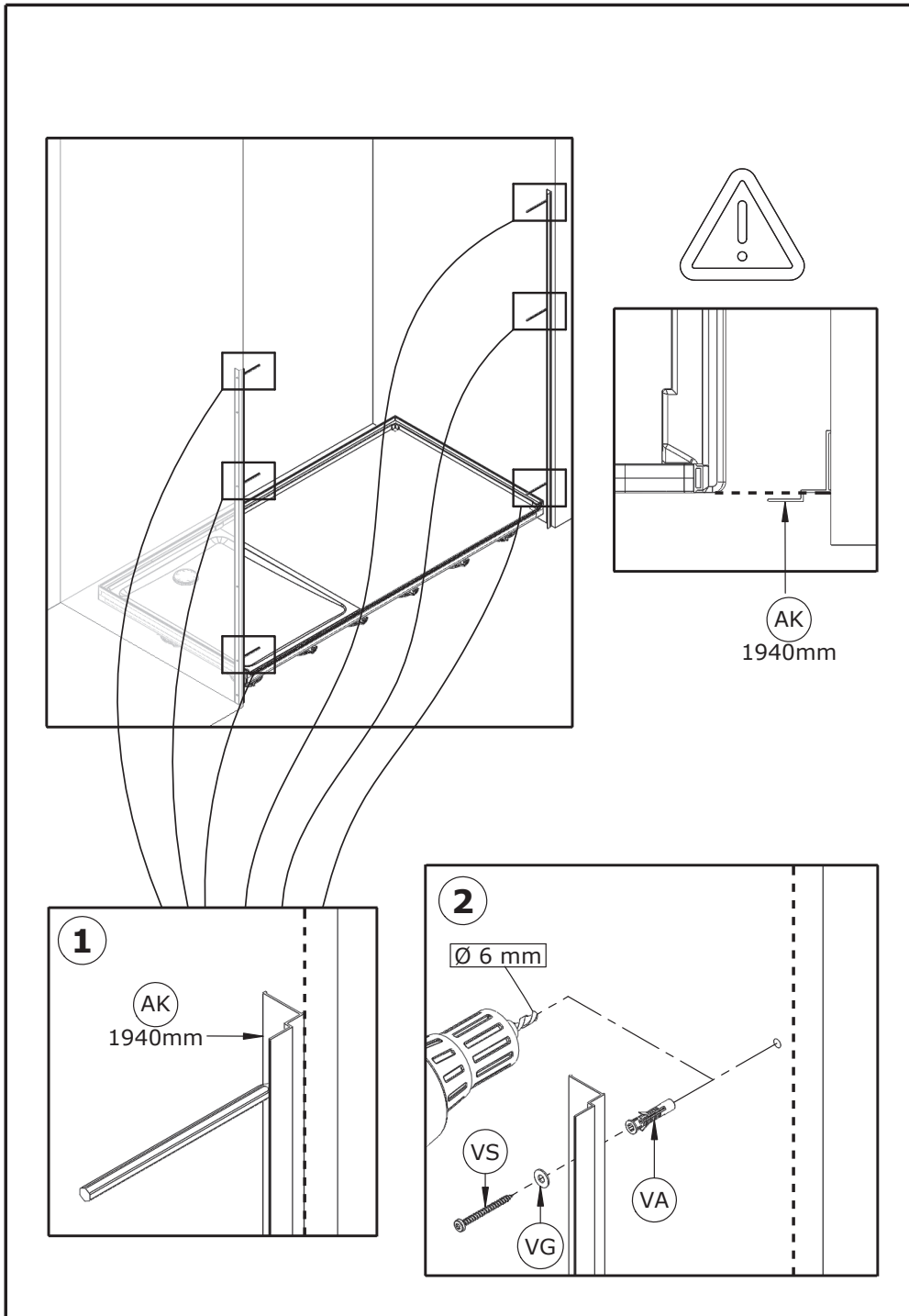



- Couper à longueur
- Cut to length
- Cortar a la medida
- Taglio a misura
- Op lengte gesneden
- Auf die Länge schneiden

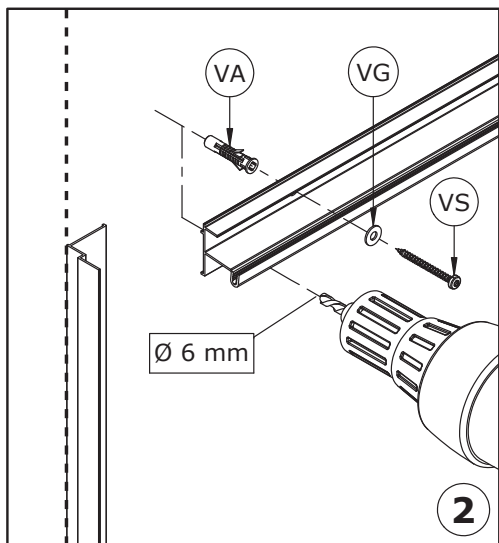
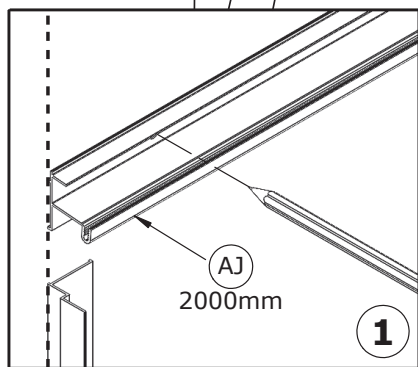
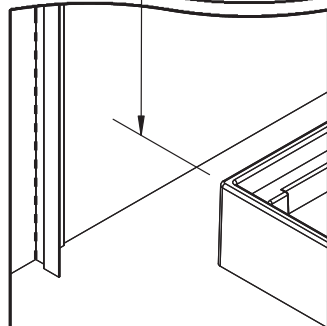
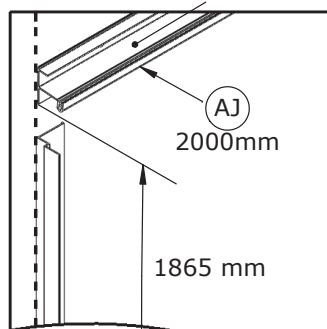
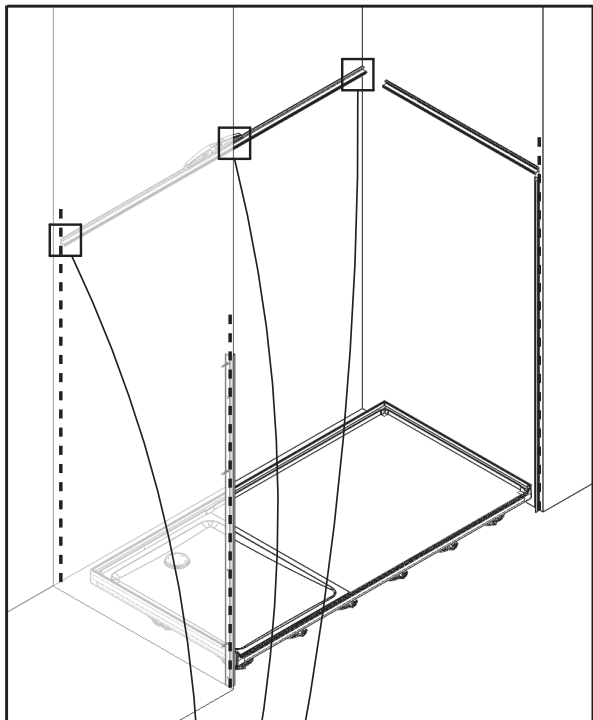

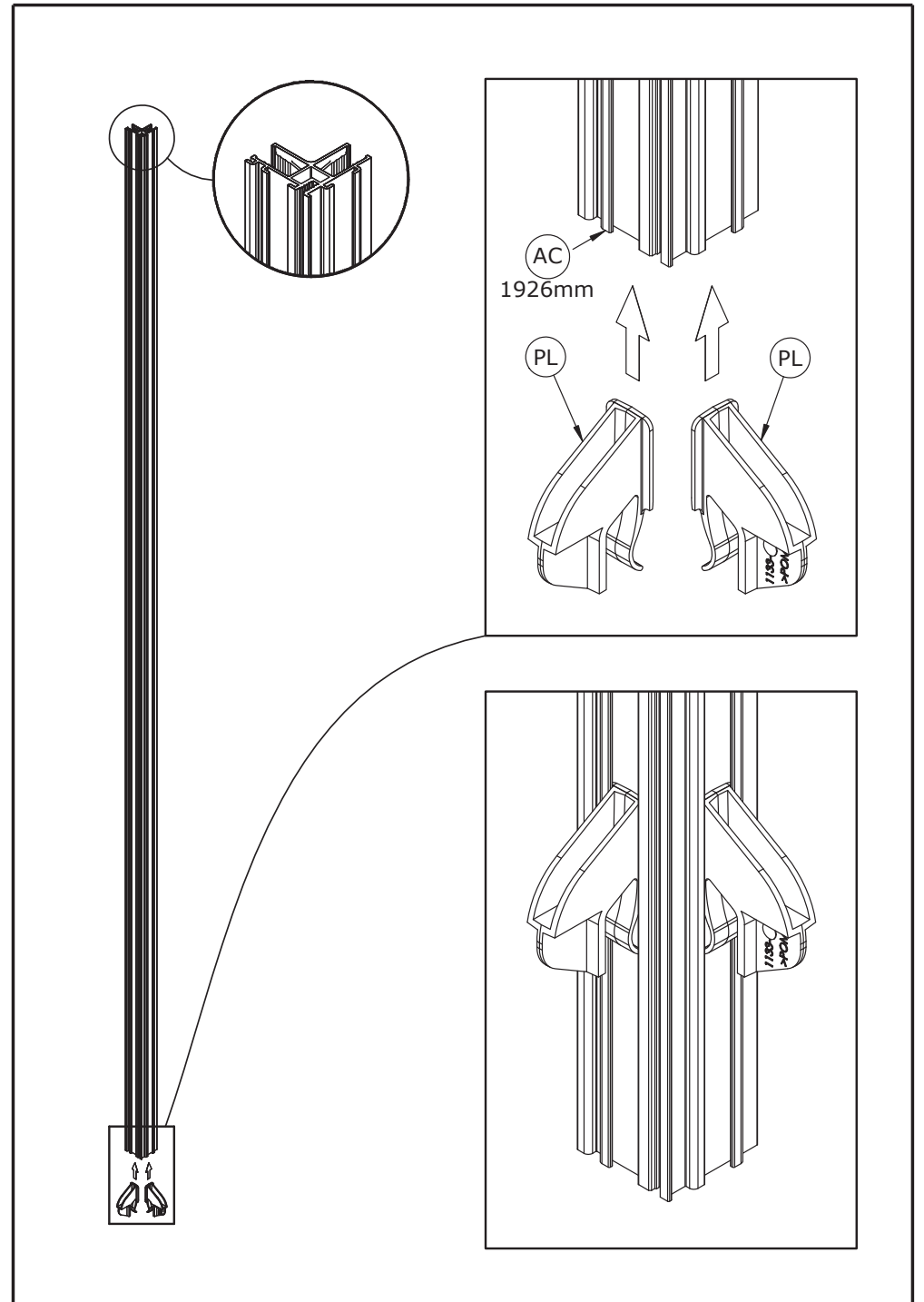
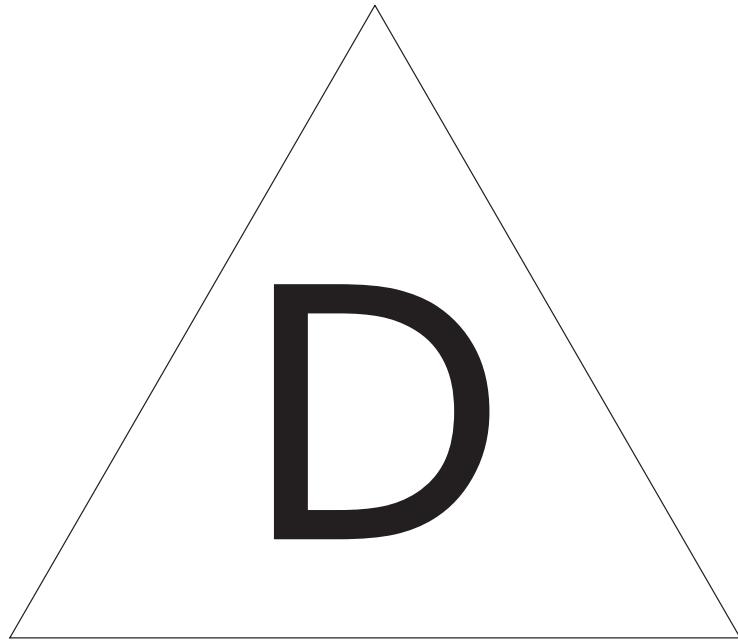

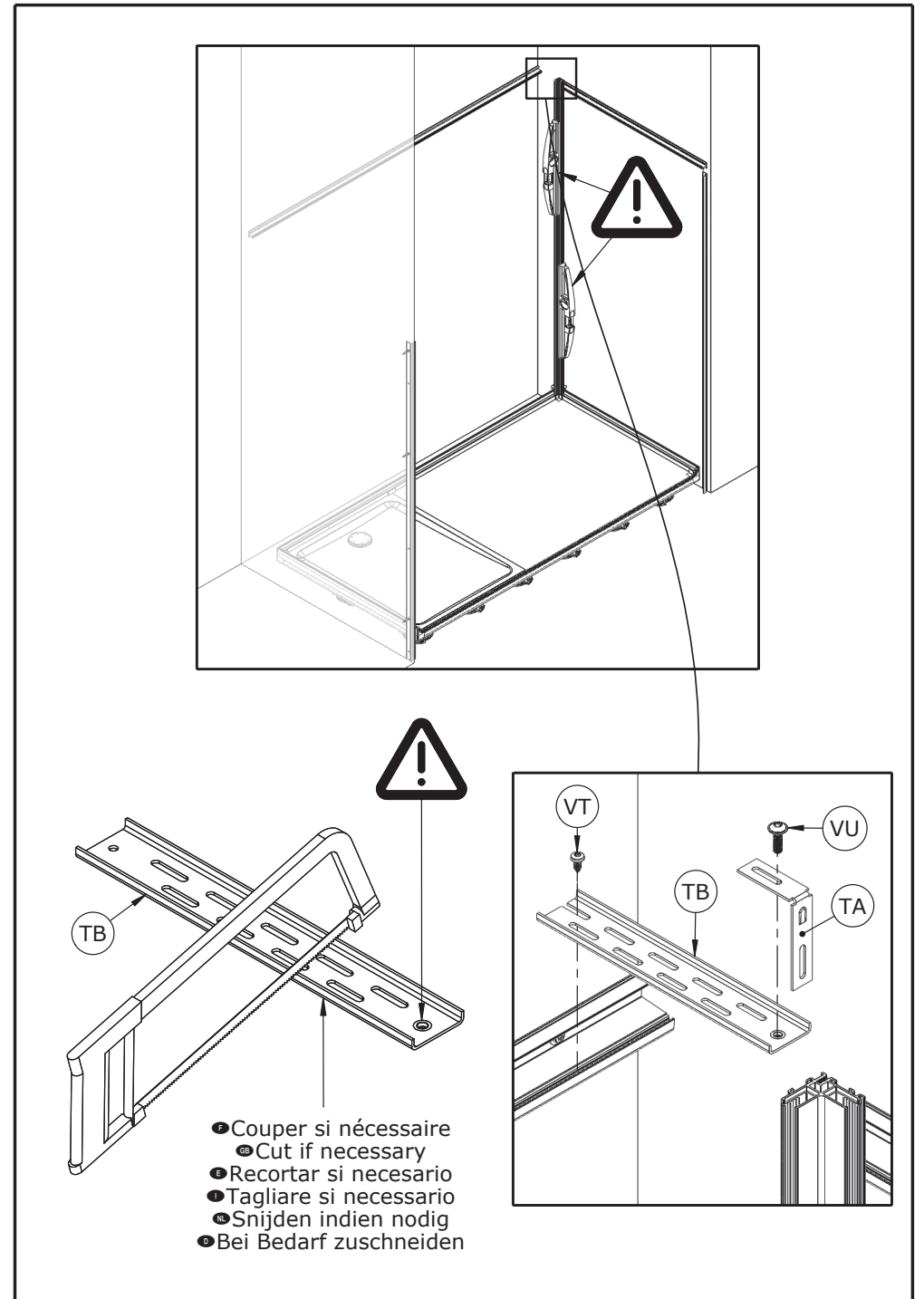
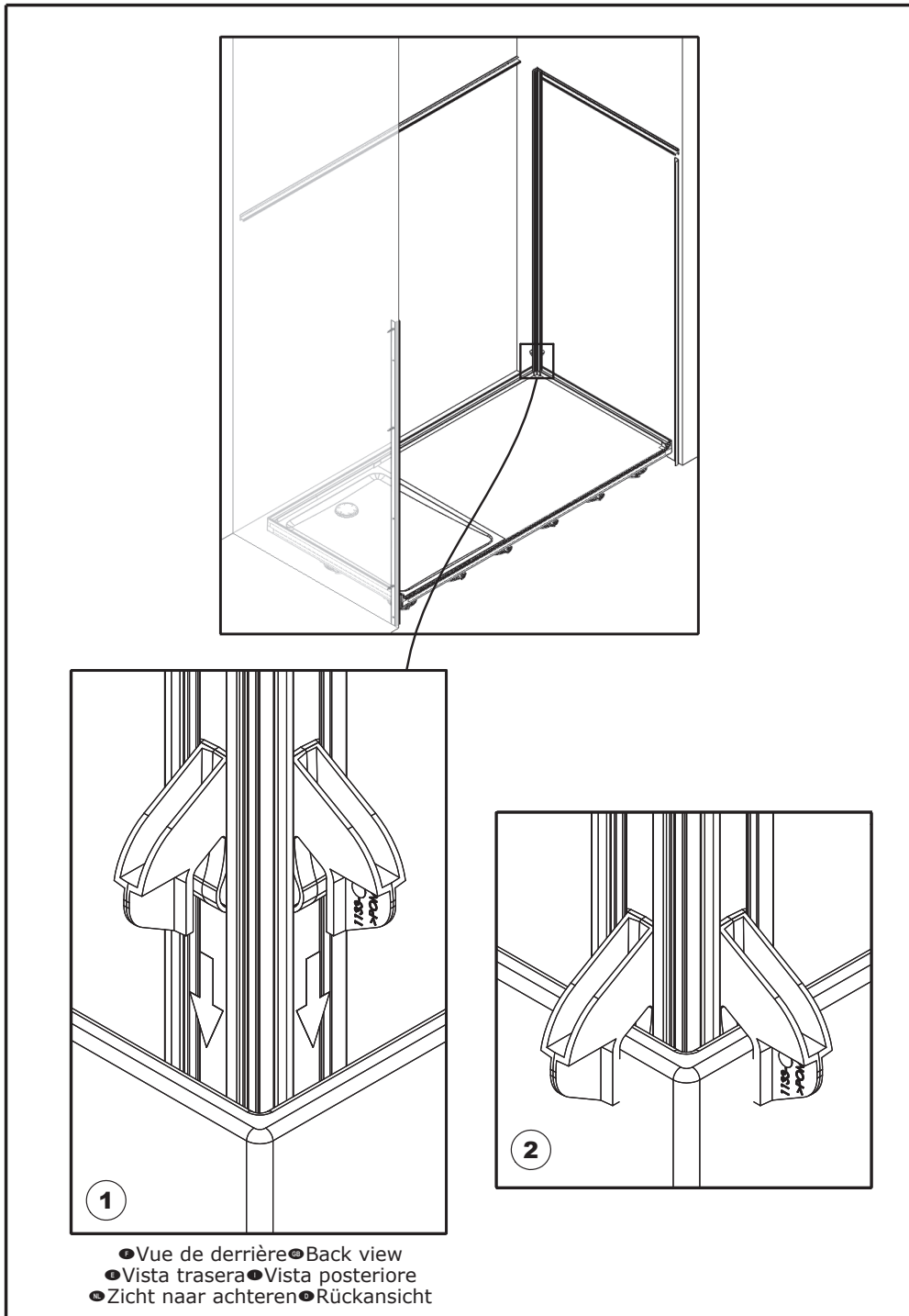

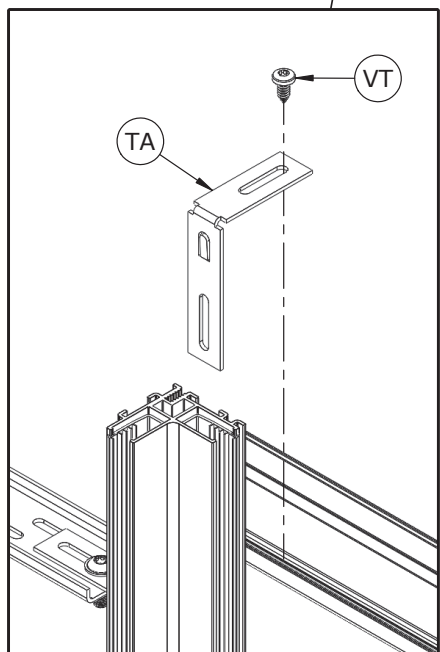
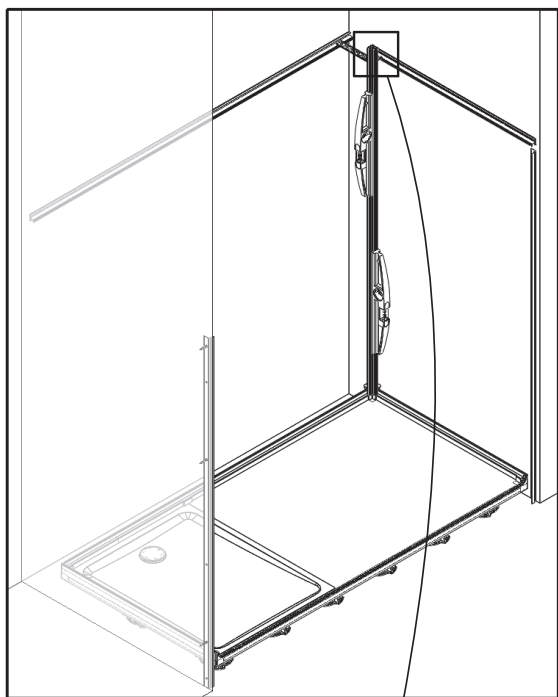

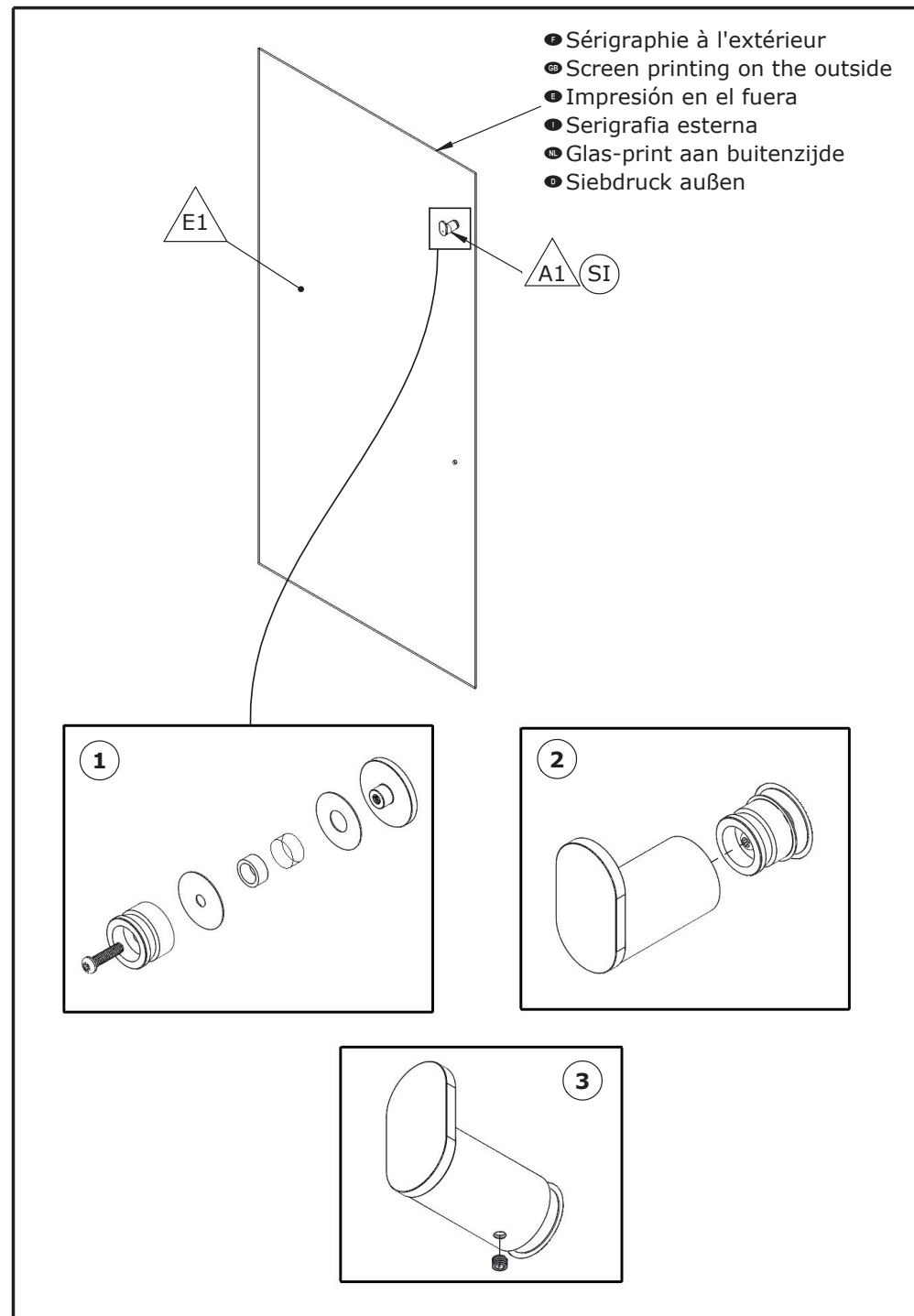
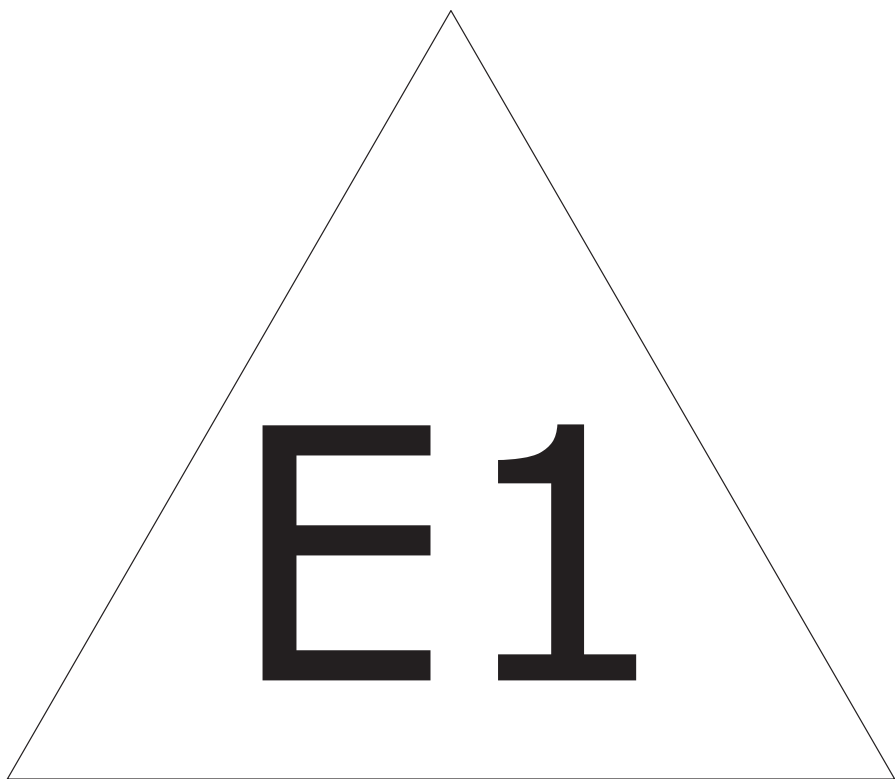

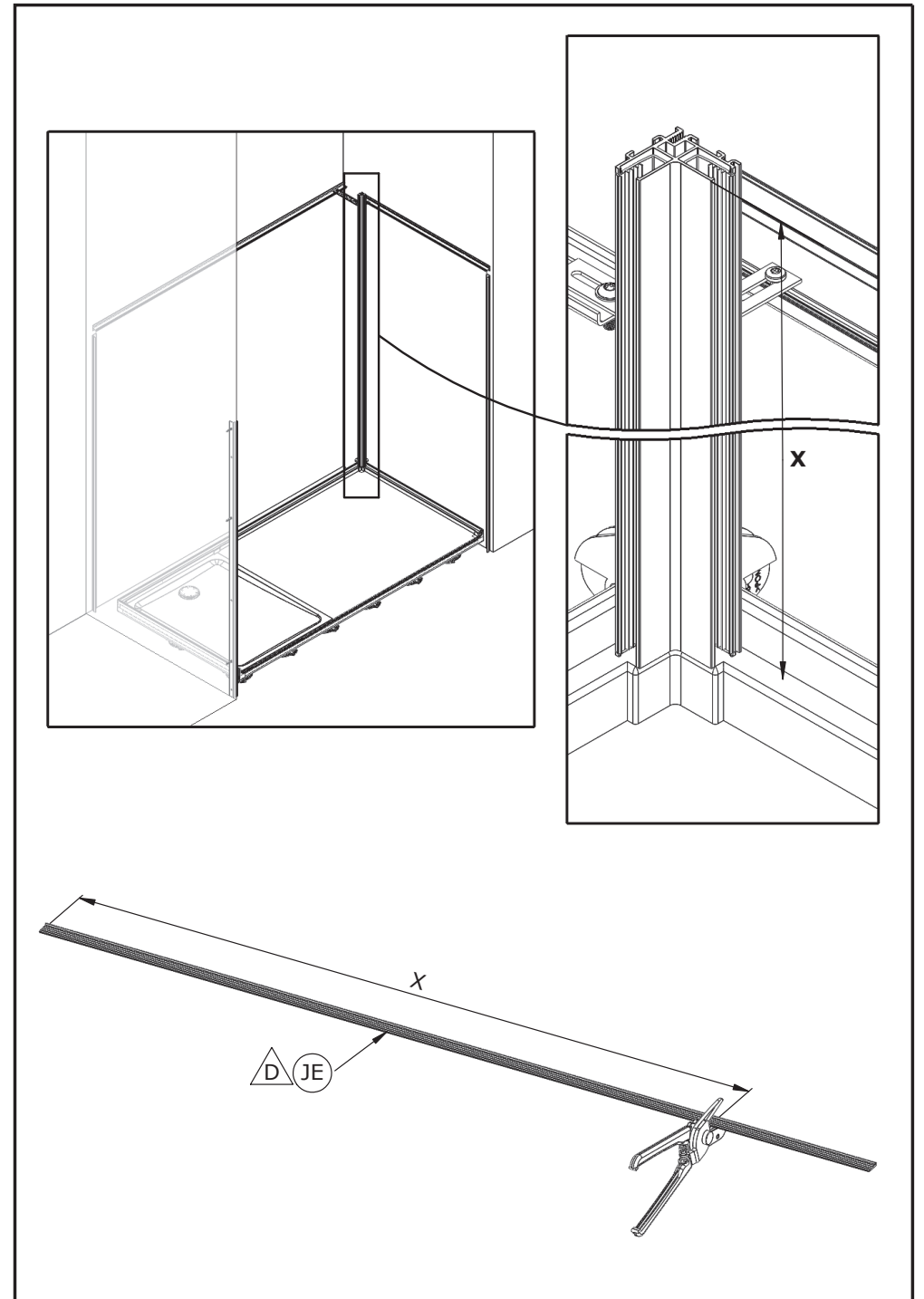
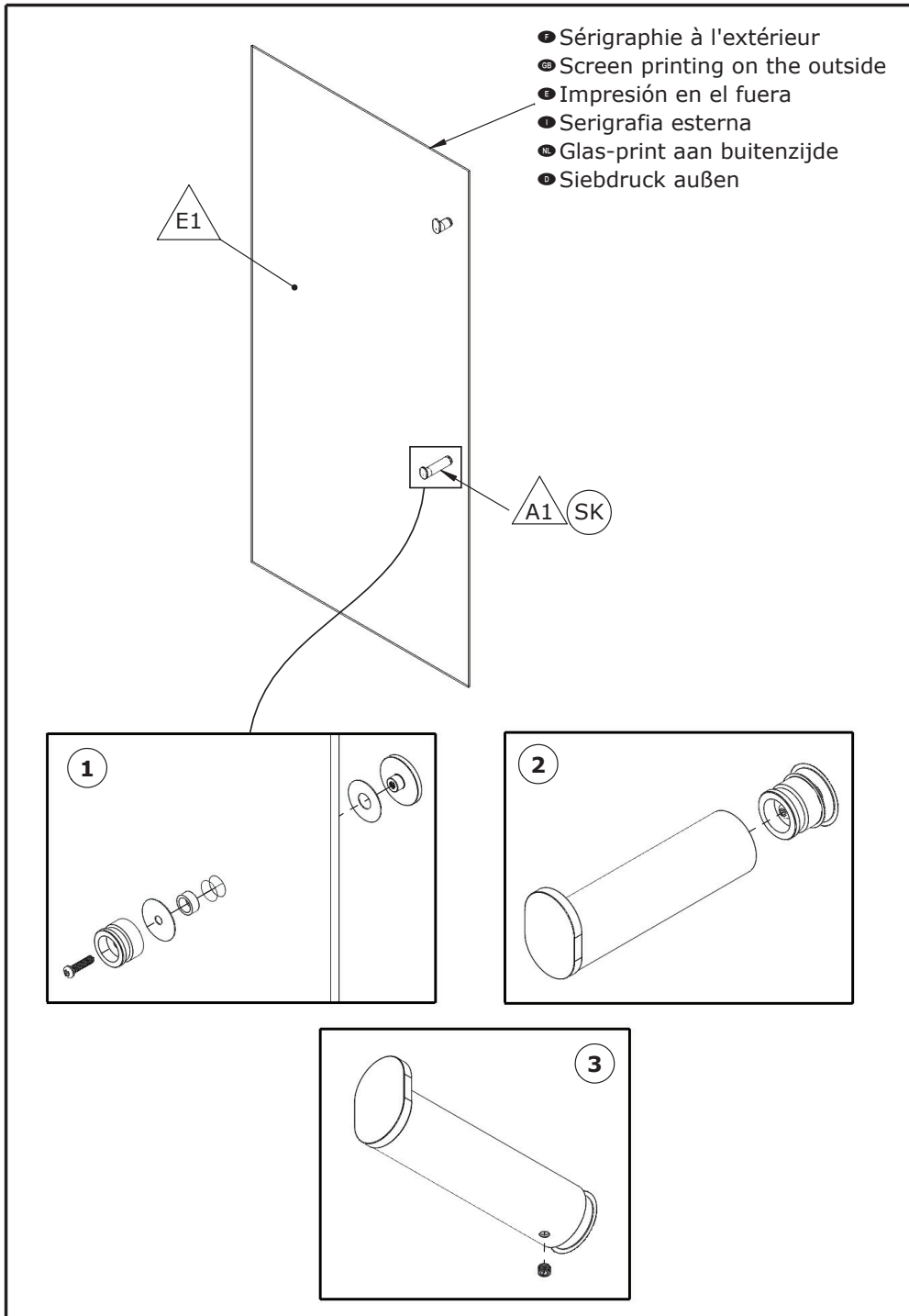

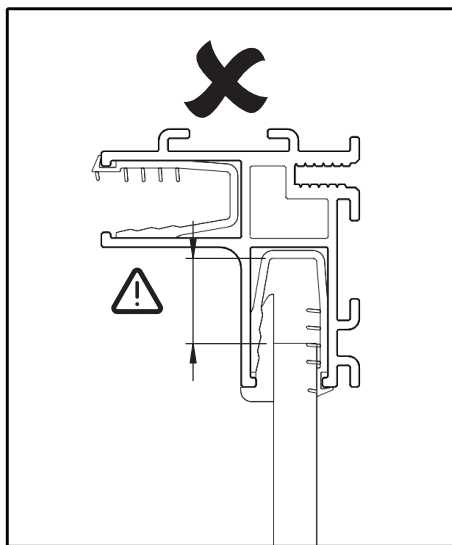
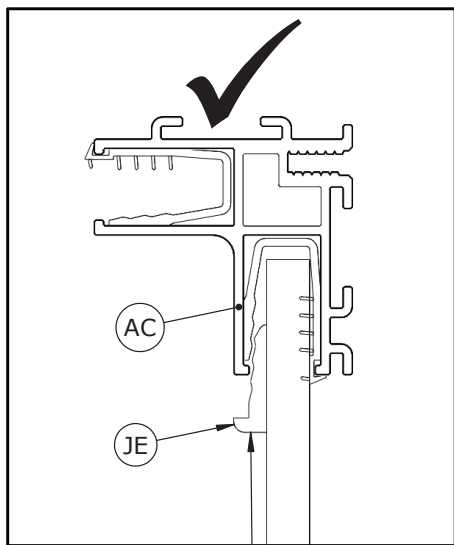
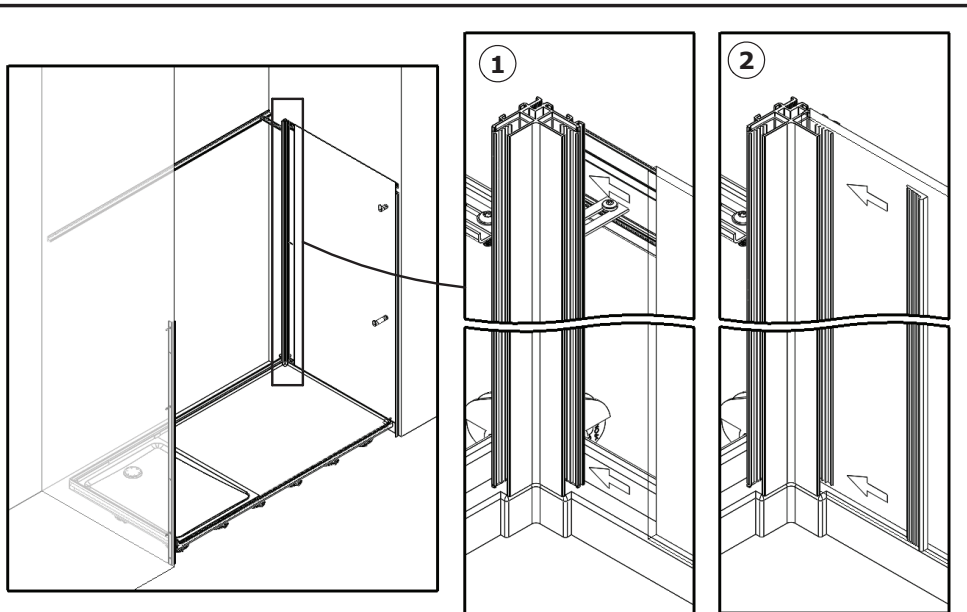

• Ne pas verrouiller • Do not block
 • No bloquear • Non bloccare
 • Blokkeer niet • Nicht blockieren

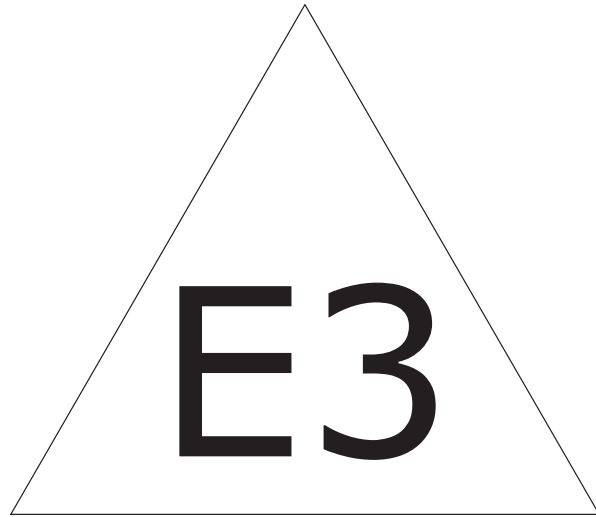

1

- Utiliser (QB) pour placer (QA)
- Use (QB) to place (QA)
- Utilice (QB) para colocar (QA)
- Utilizzare (QB) per posizionare (QA)
- Gebruik (QB) plaatsen (QA)
- Verwenden Sie (QB) hinstellen (QA)

2

- Se référer à la notice pour le montage
- Refer to the instructions for assembly
- Consulte el manual para el montaje
- Fare riferimento alle istruzioni per il montaggio
- Raadpleeg de handleiding voor de installatie
- Beachten Sie die Montageanleitung

⚠

- Mettre en contact (QB) Get in touch
- Poner en contacto (QB) Mettiti in contatto
- In contact komen (QB) In Kontakt kommen

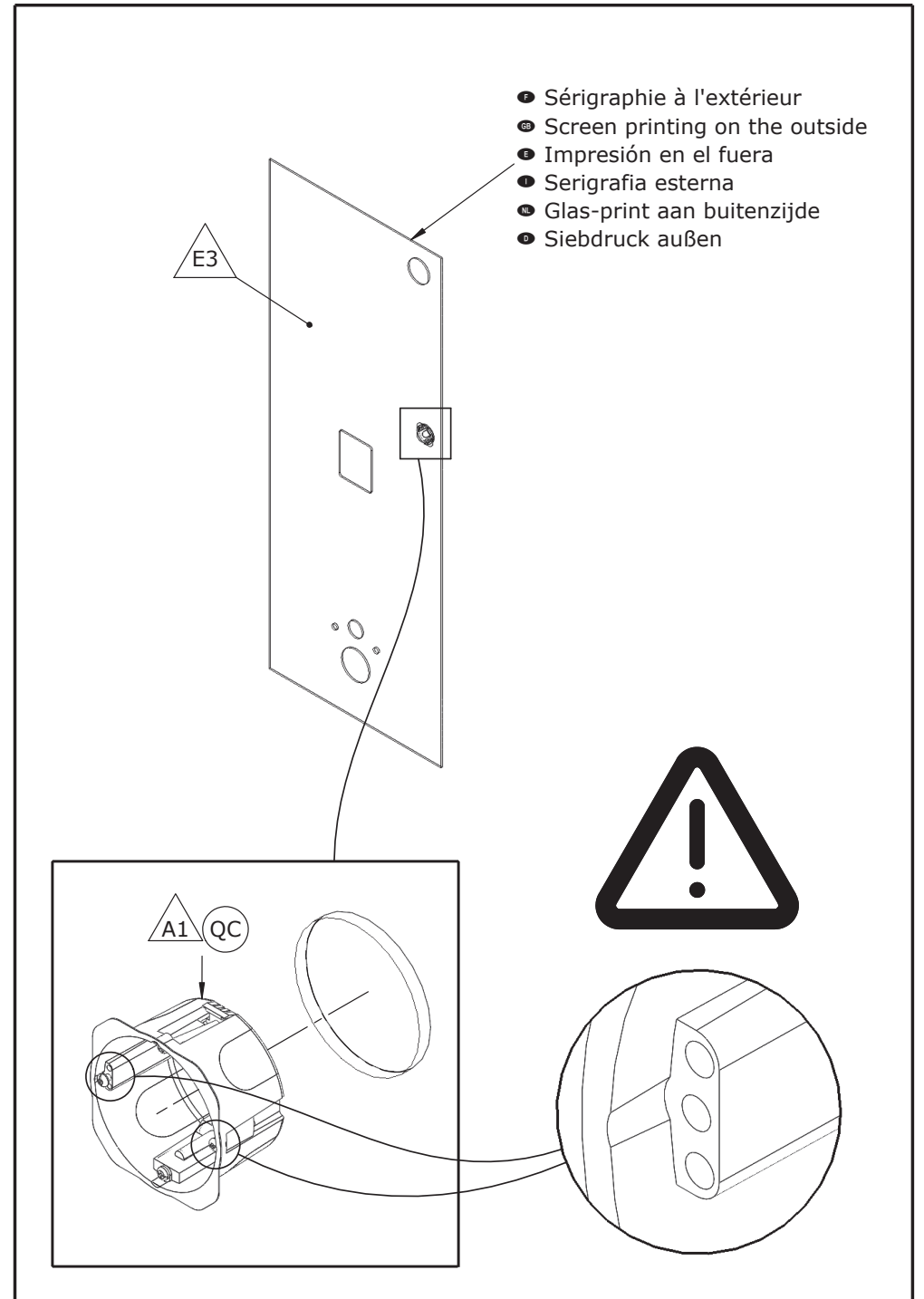
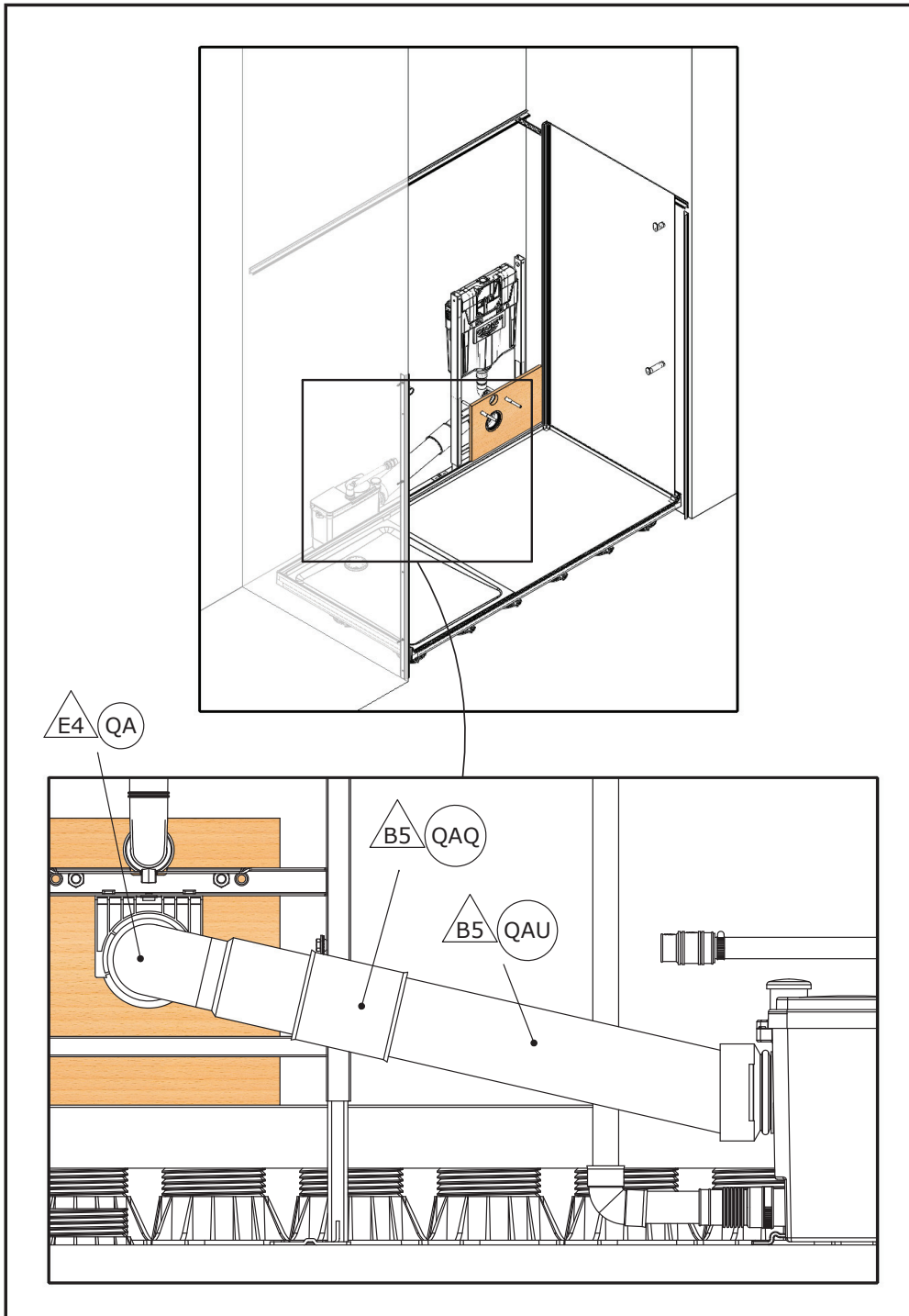

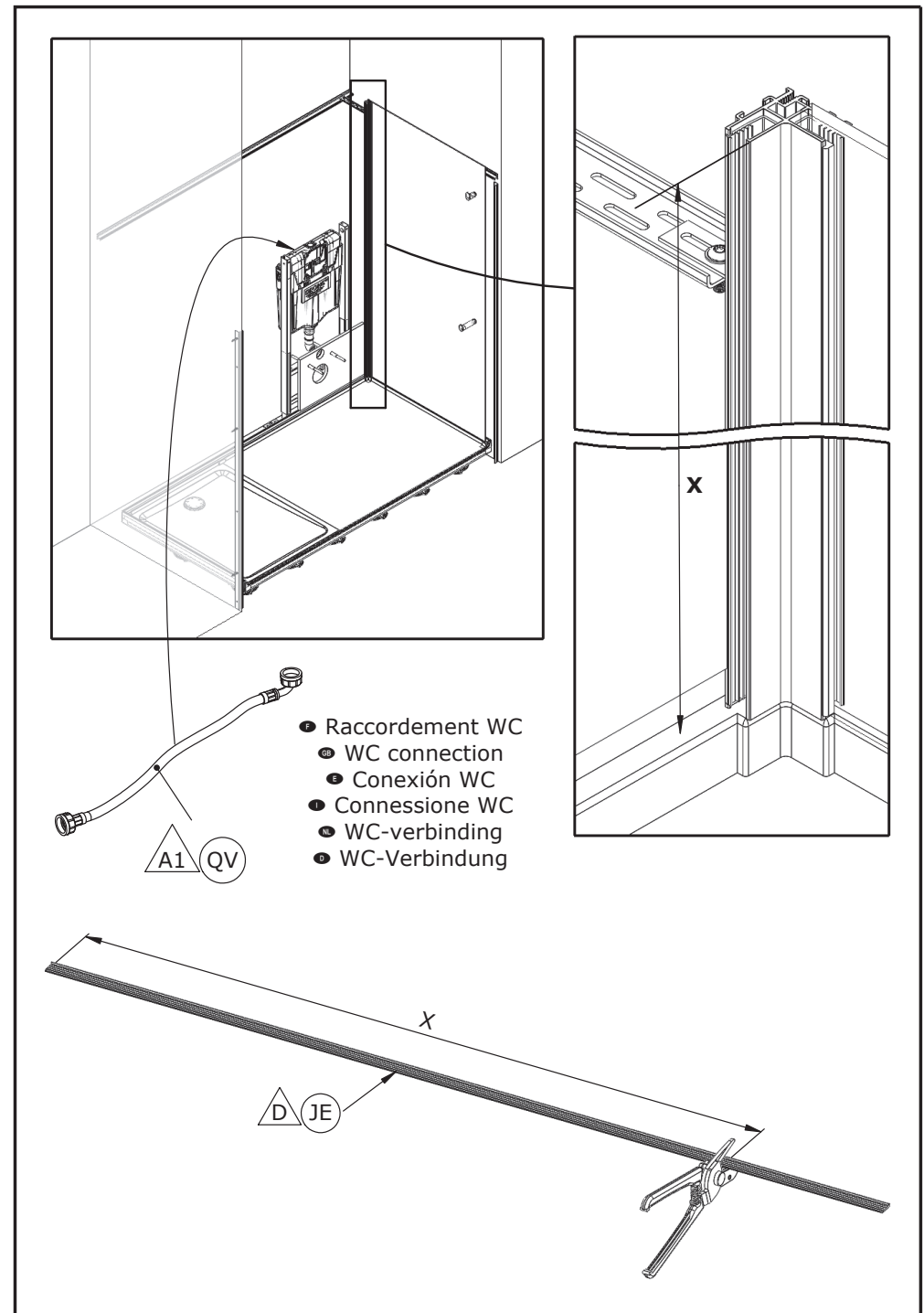
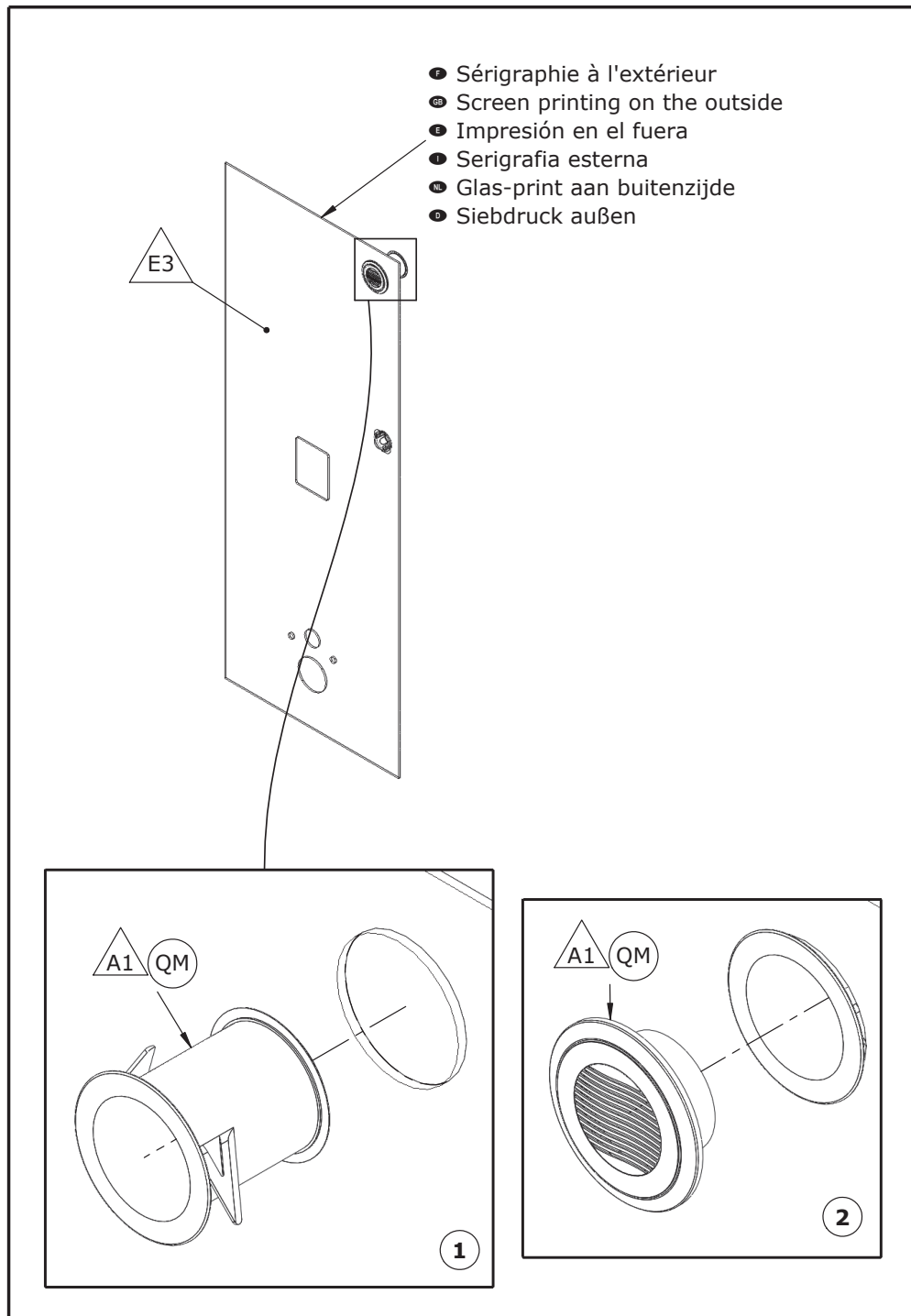

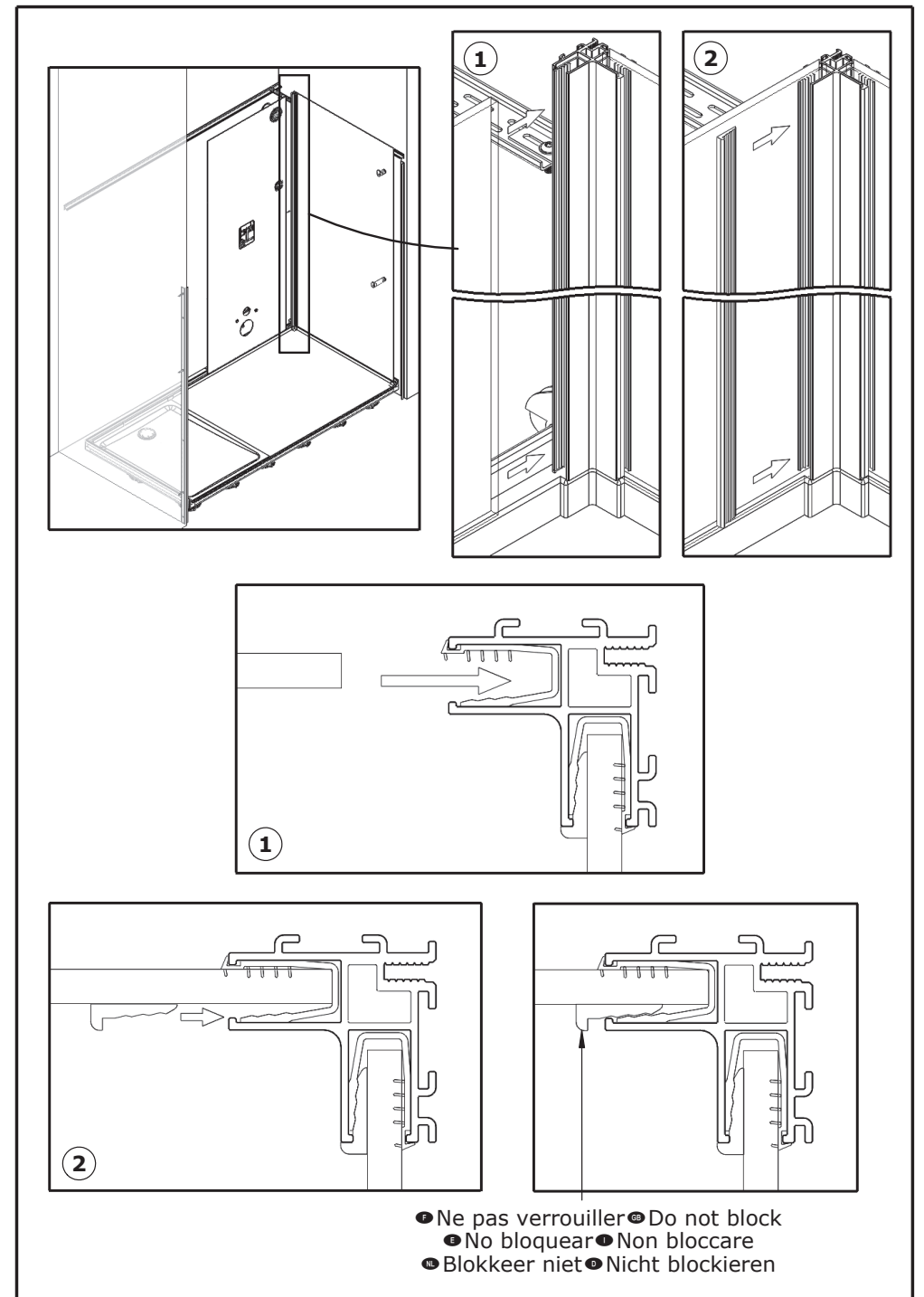
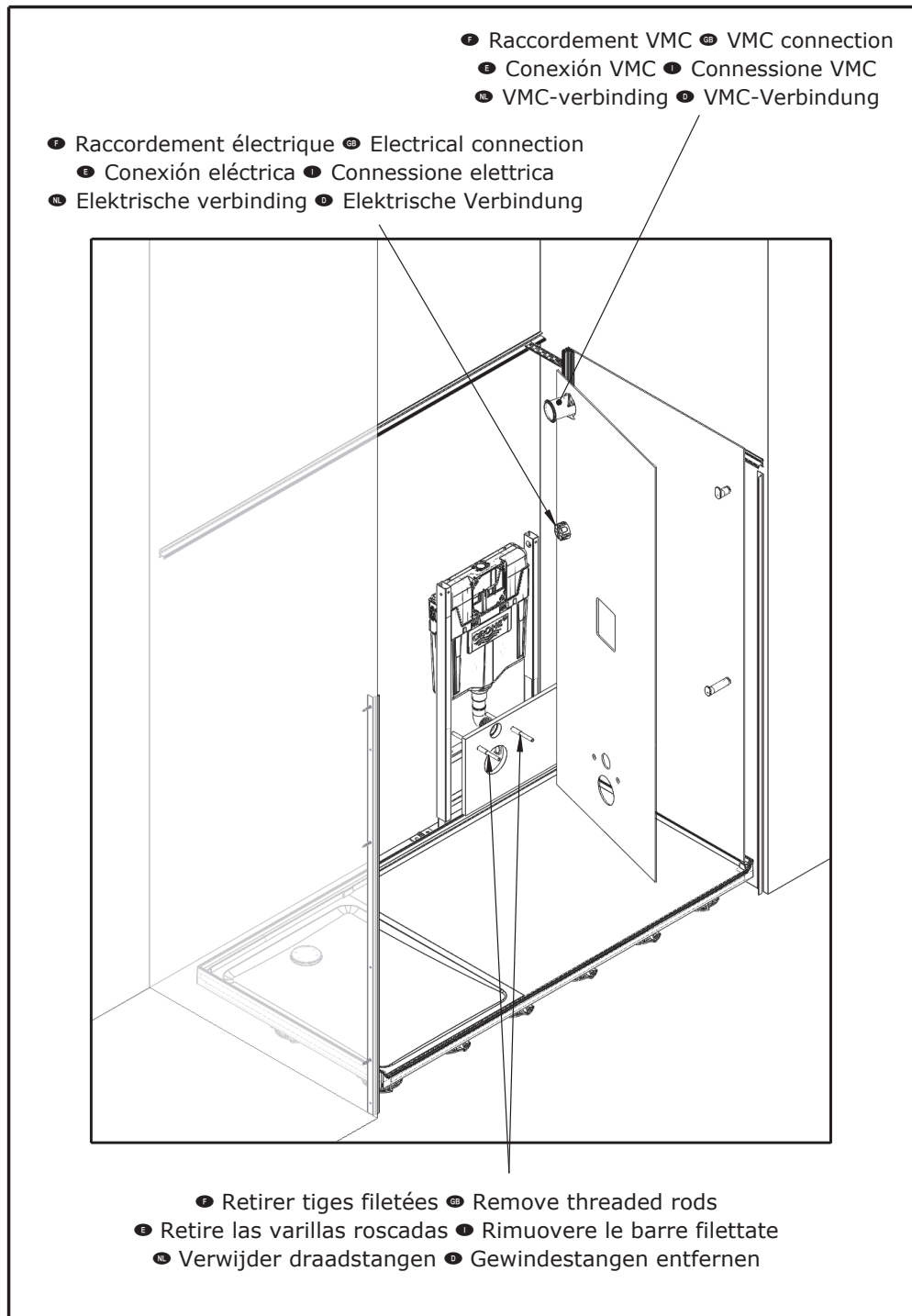

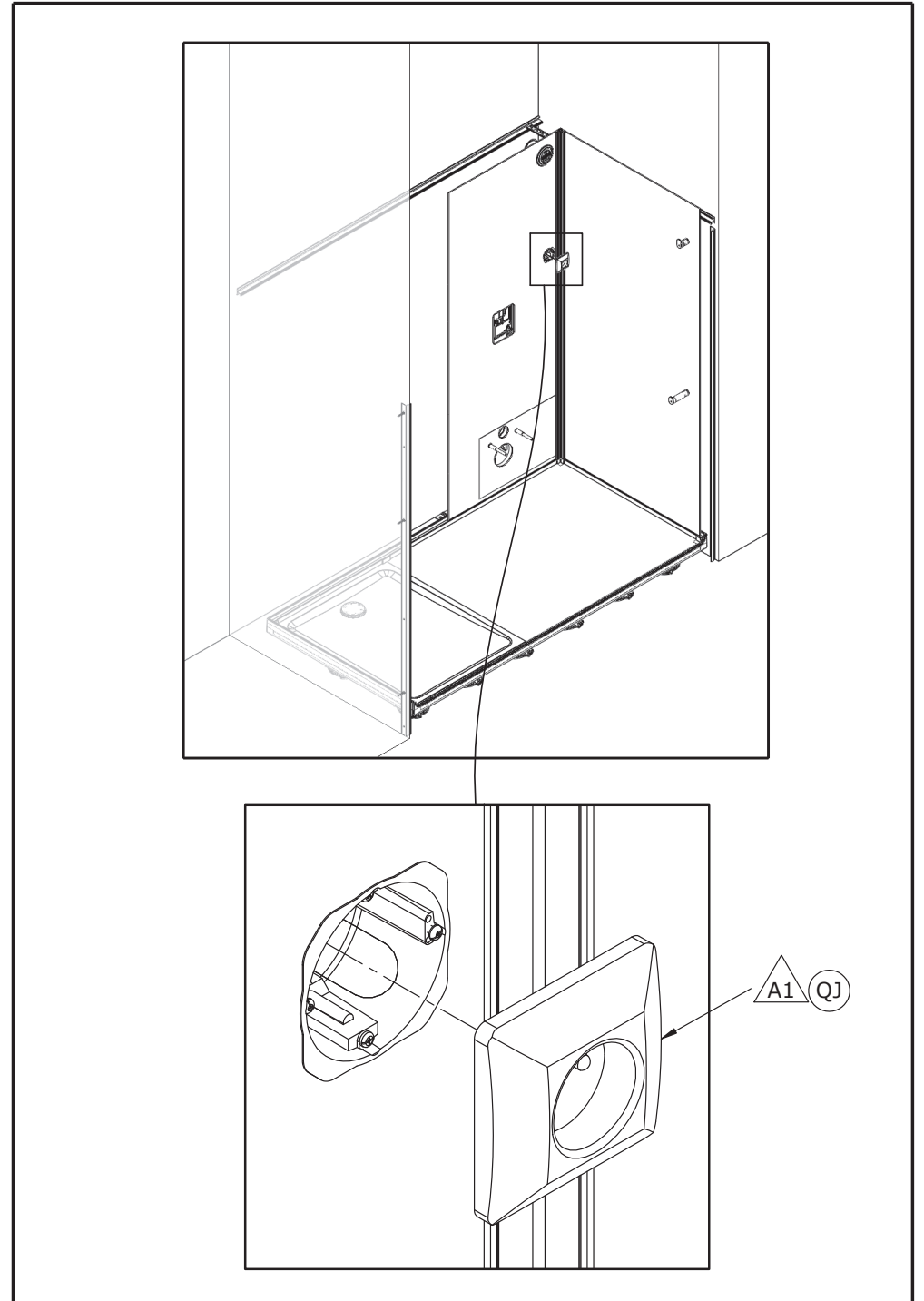
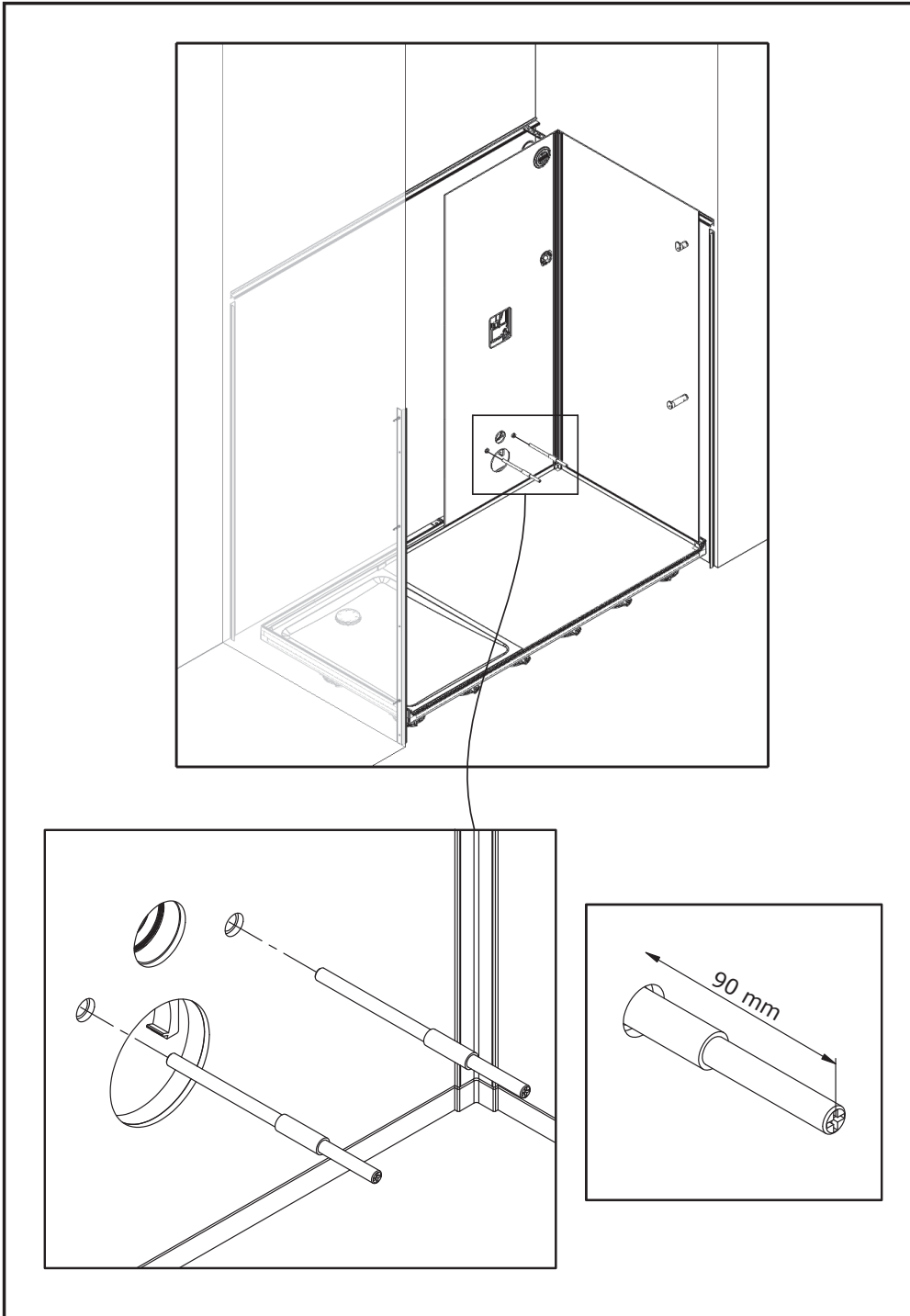

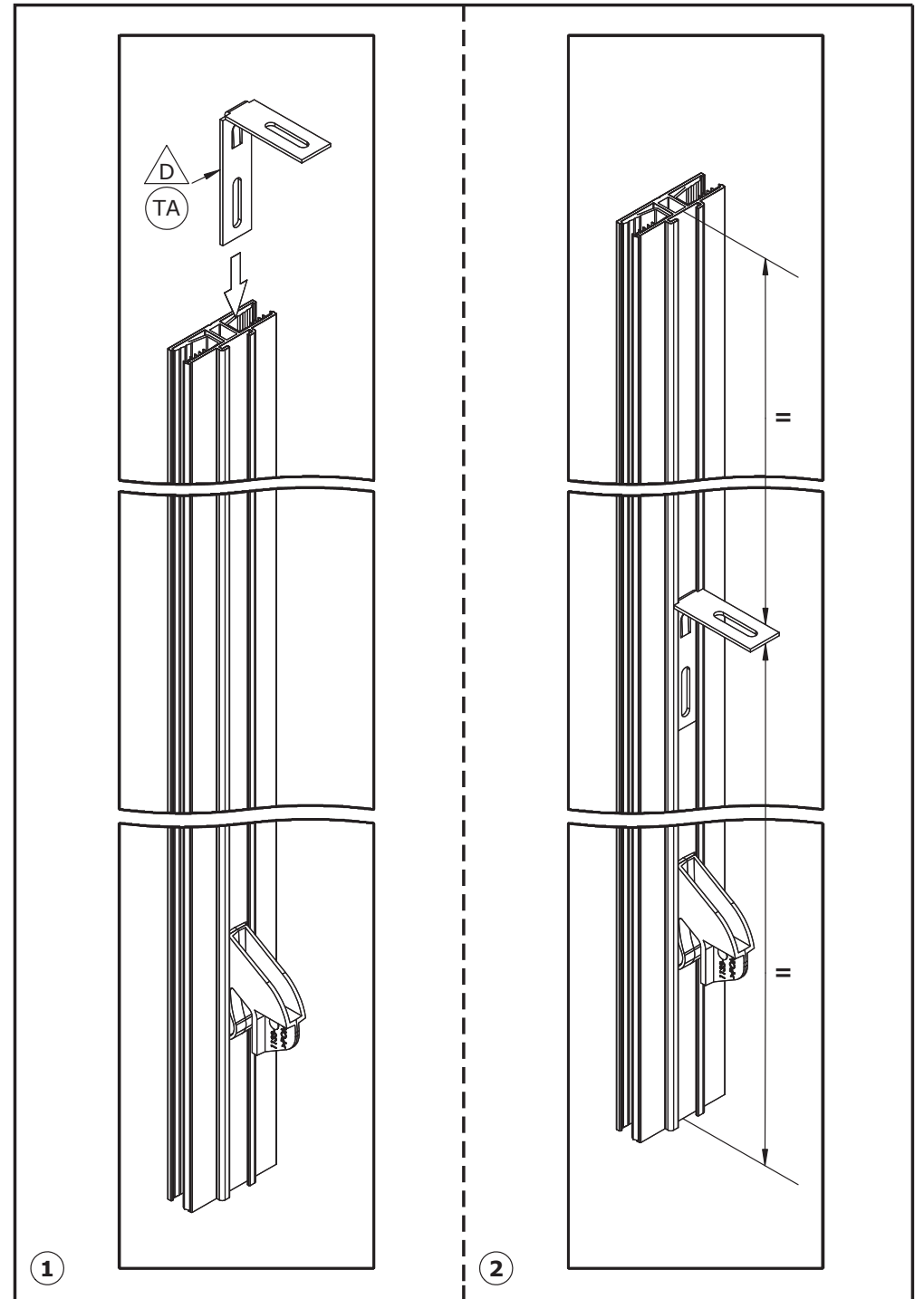
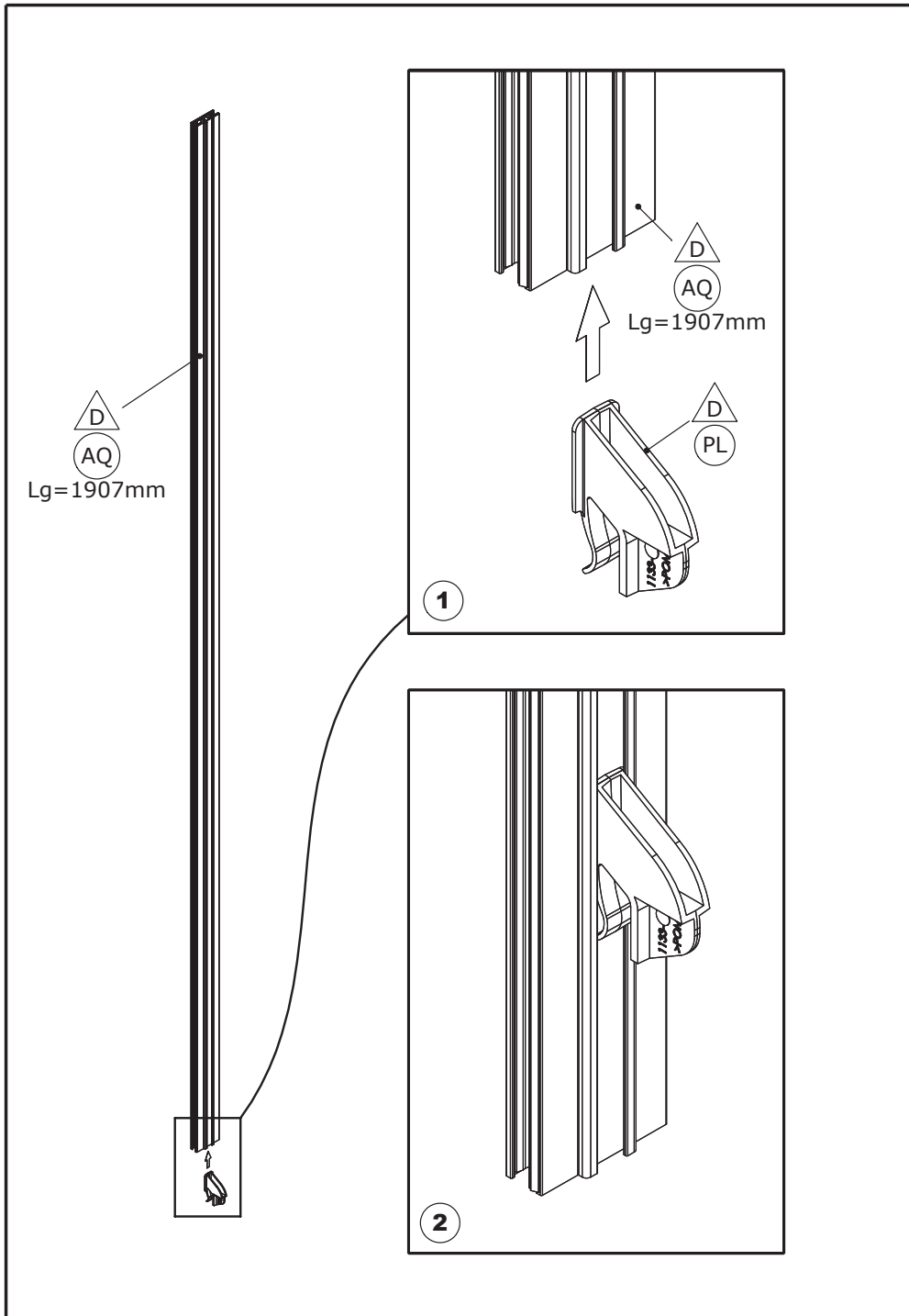

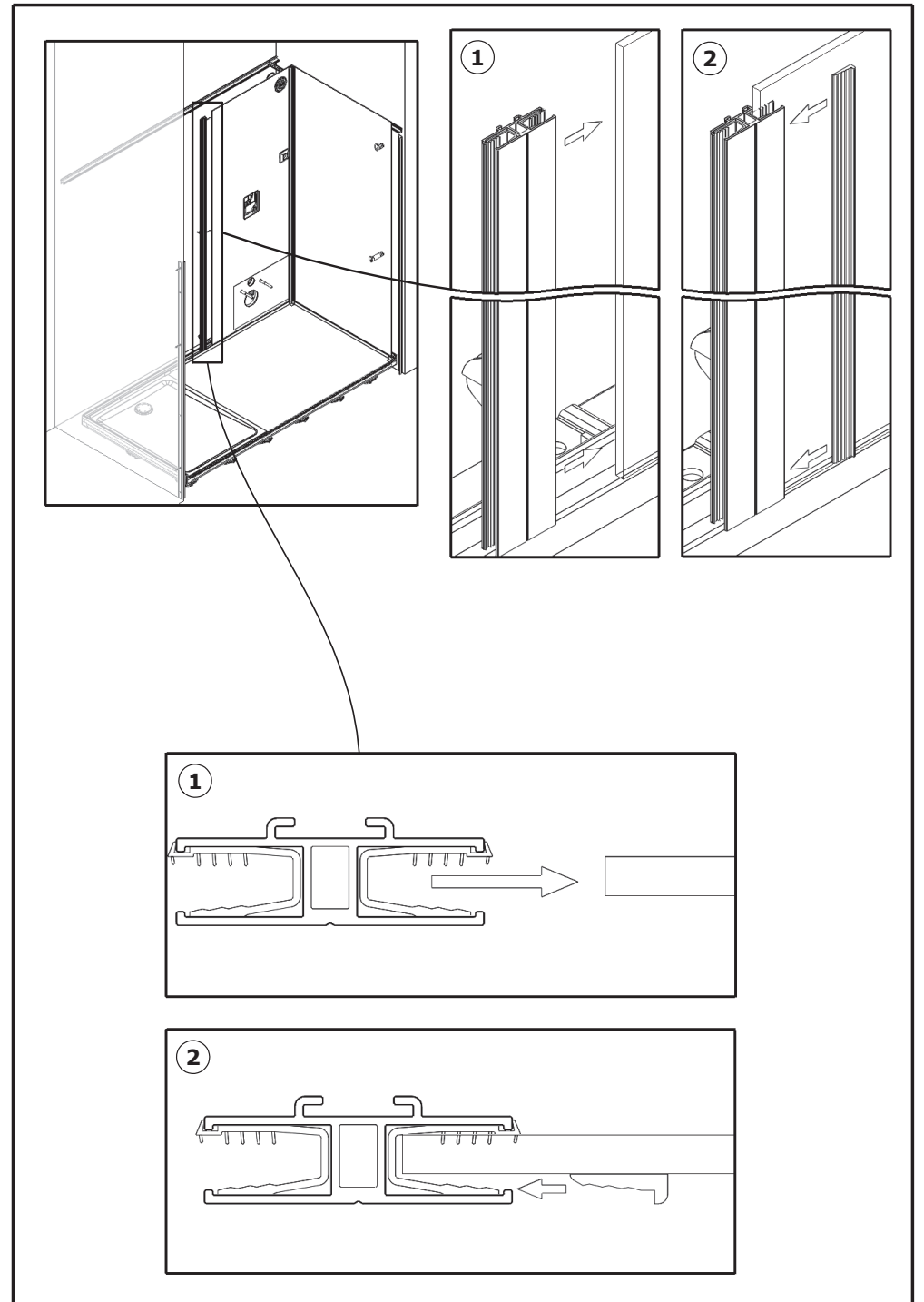
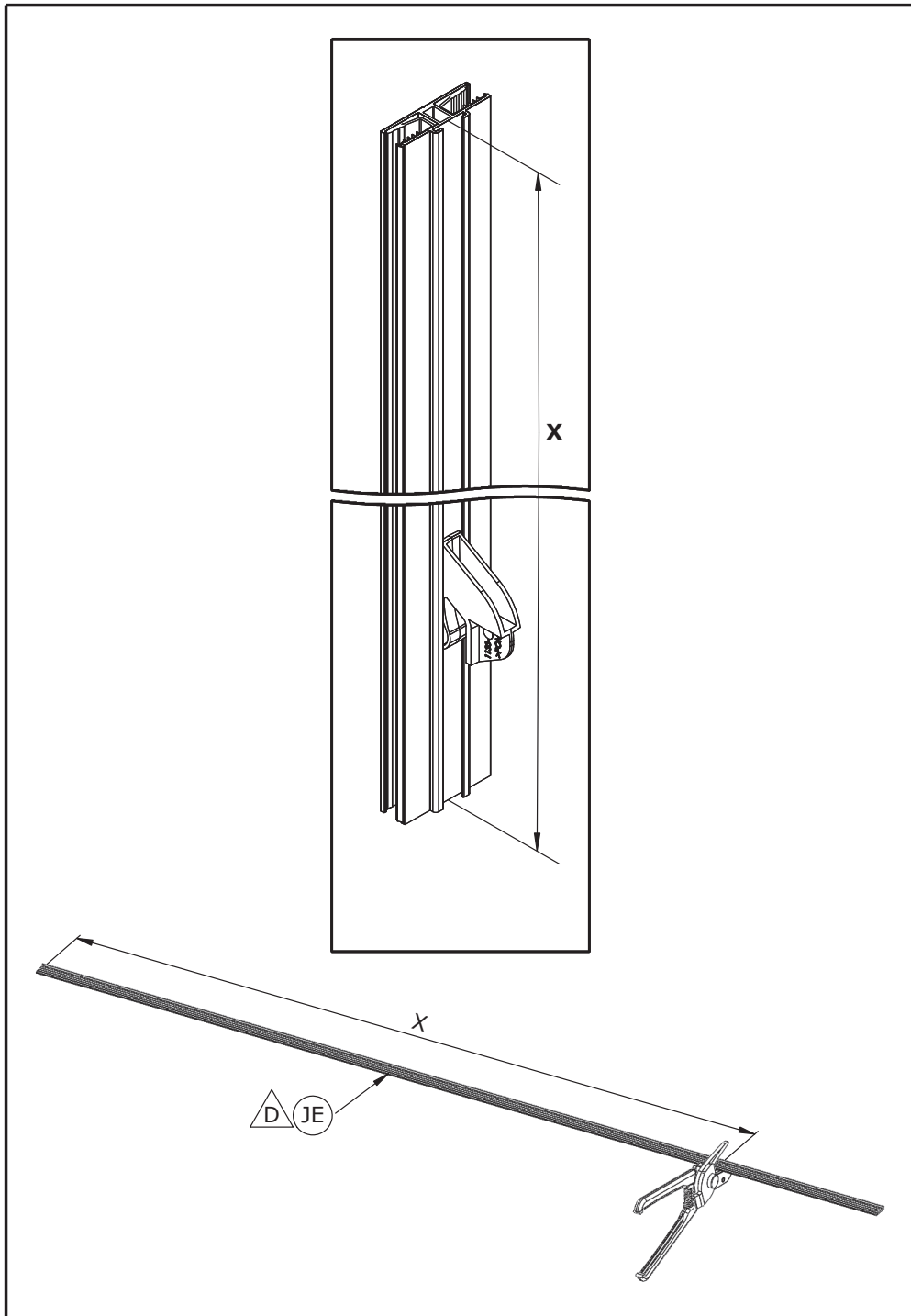

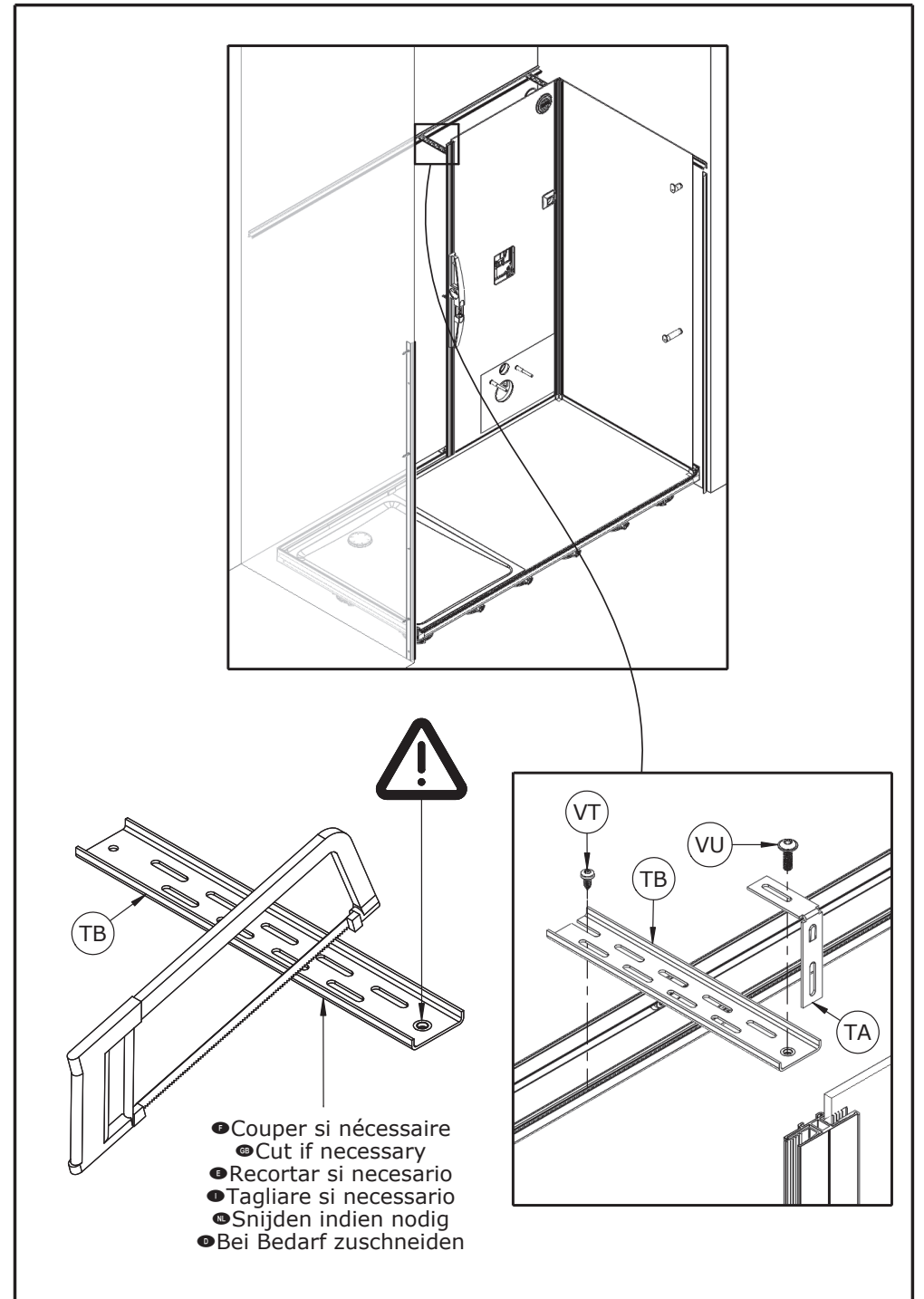
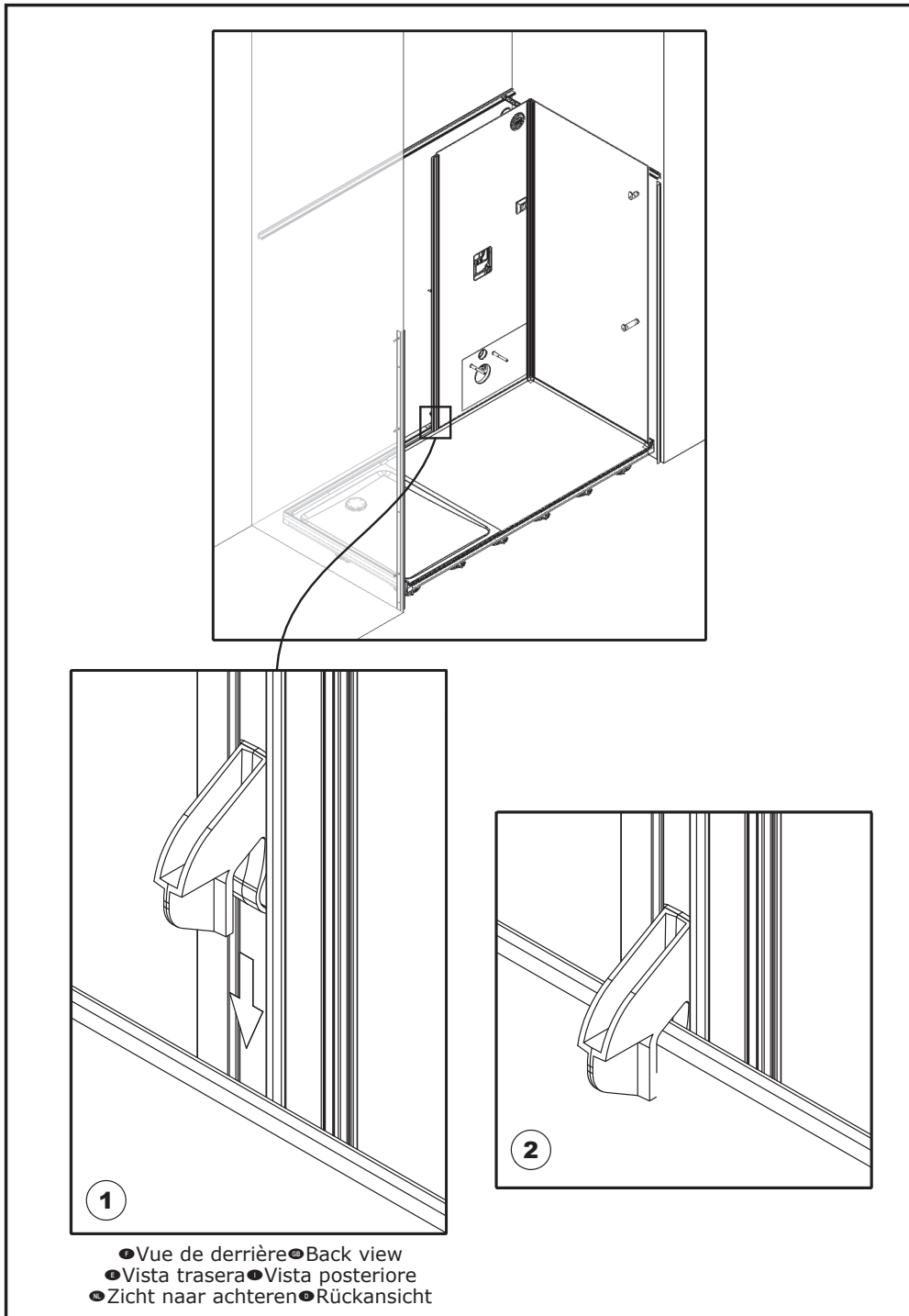

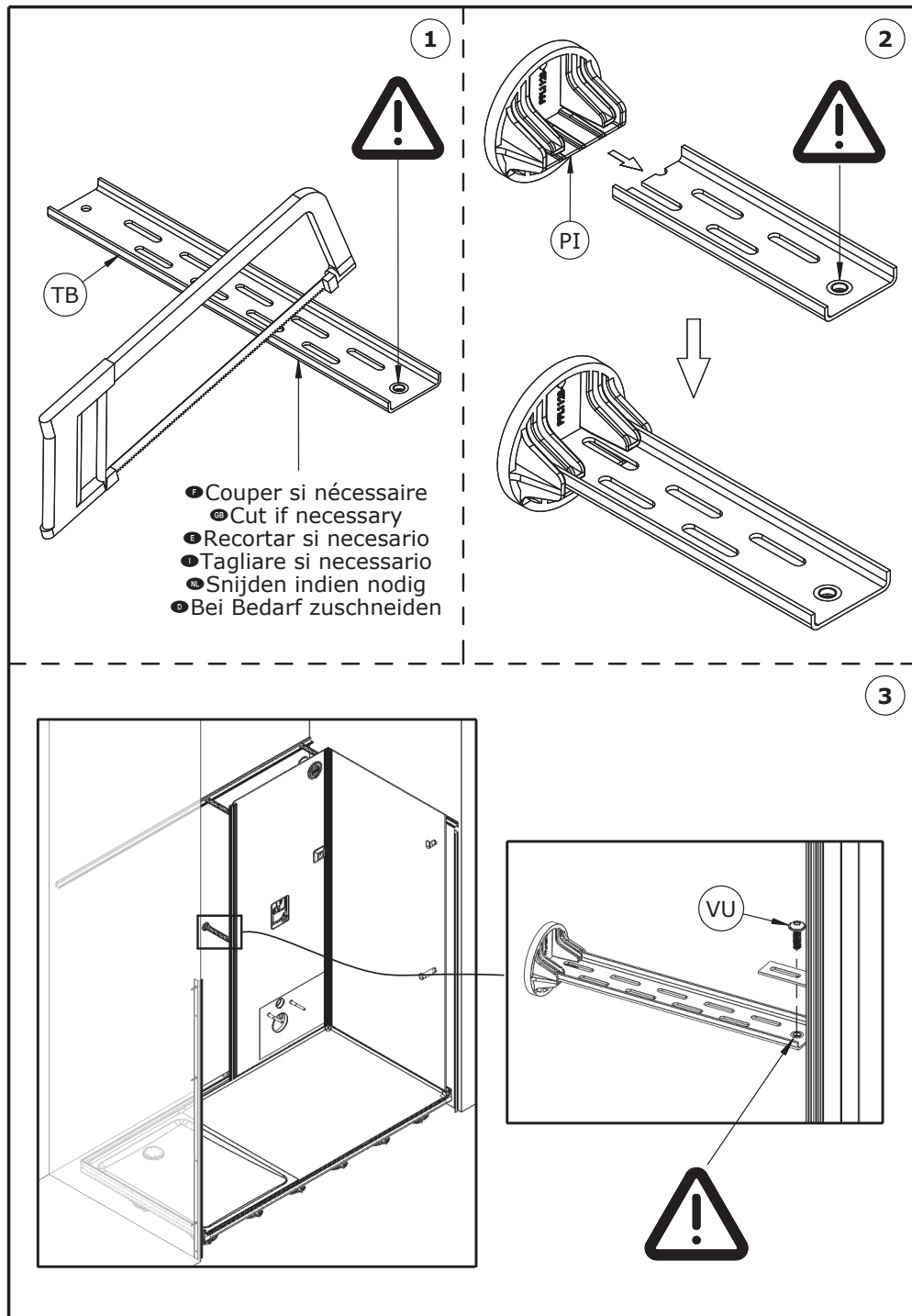

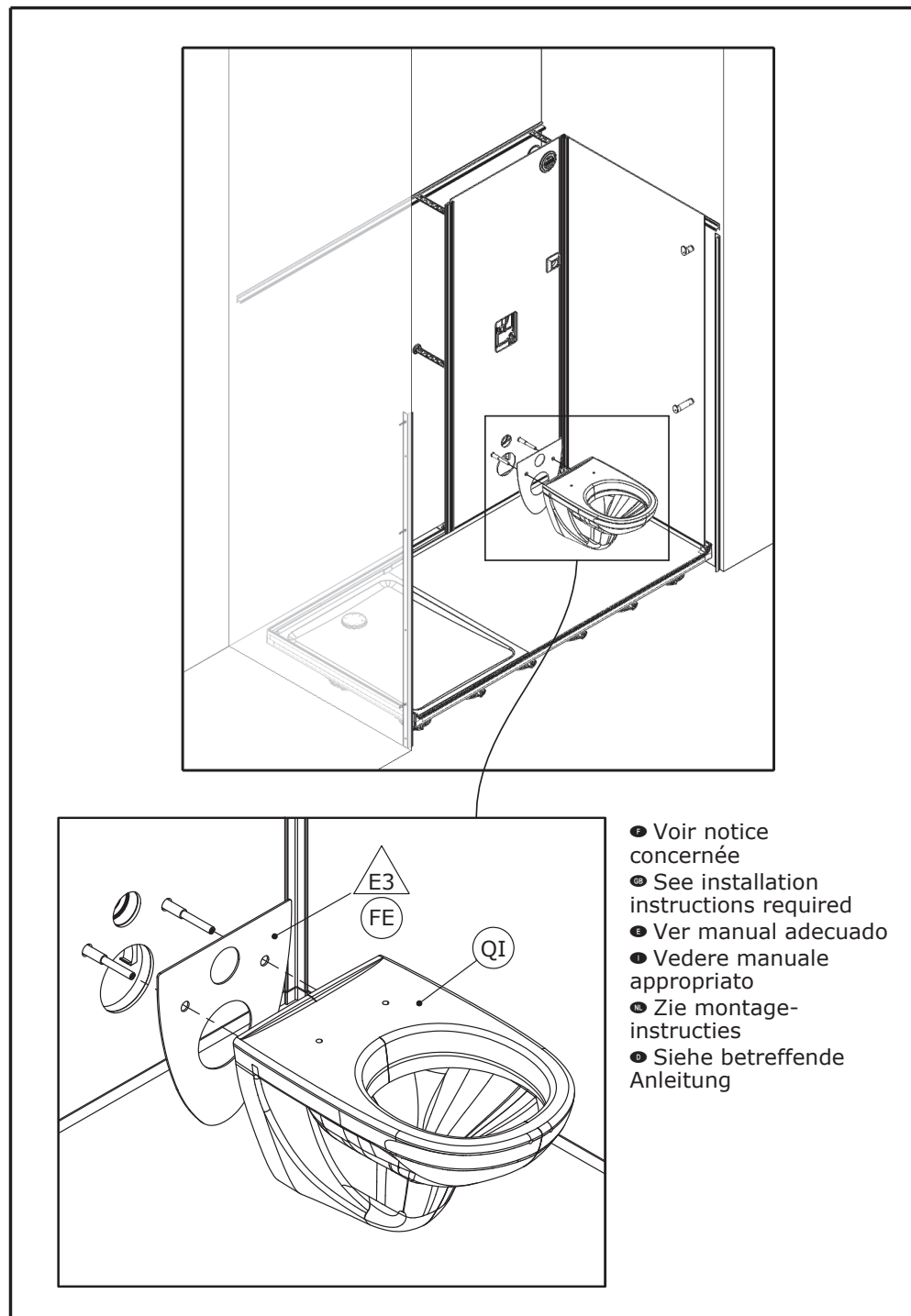

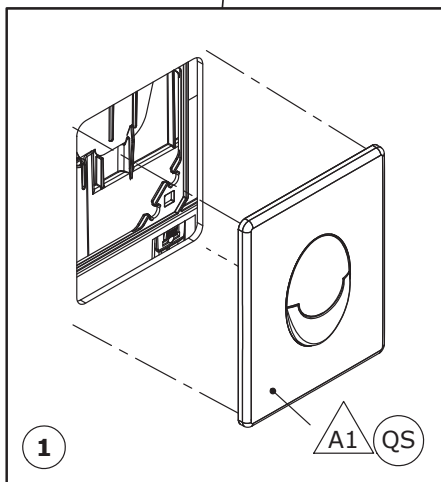
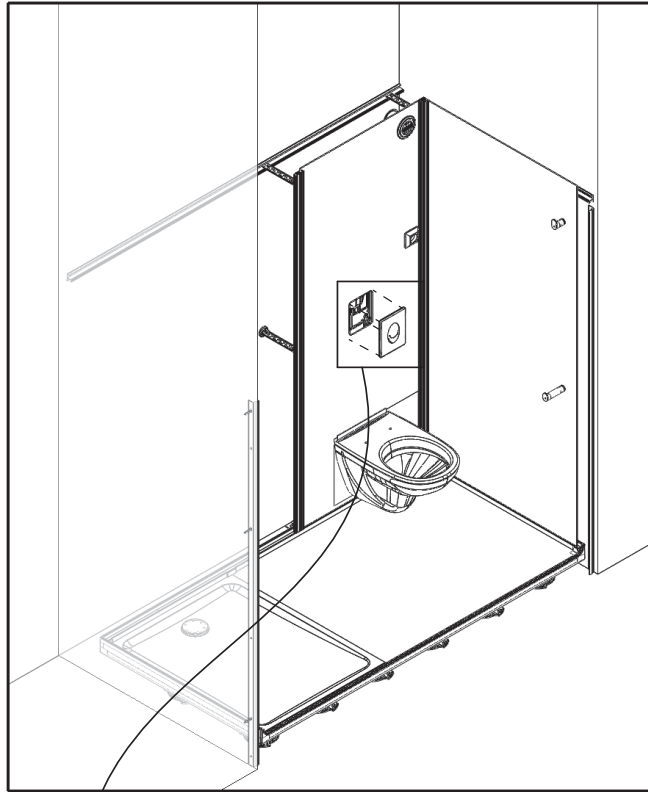

2

- Effectuer un test en eau avant de poursuivre le montage
- Perform a water test before continuing with the assembly
- Realice una prueba de agua antes de continuar con el montaje
- Eseguire un test dell'acqua prima di continuare con l'assemblaggio
- Voer een watertest uit voordat u verder gaat met de montage
- Führen Sie einen Wassertest durch, bevor Sie mit der Montage fortfahren

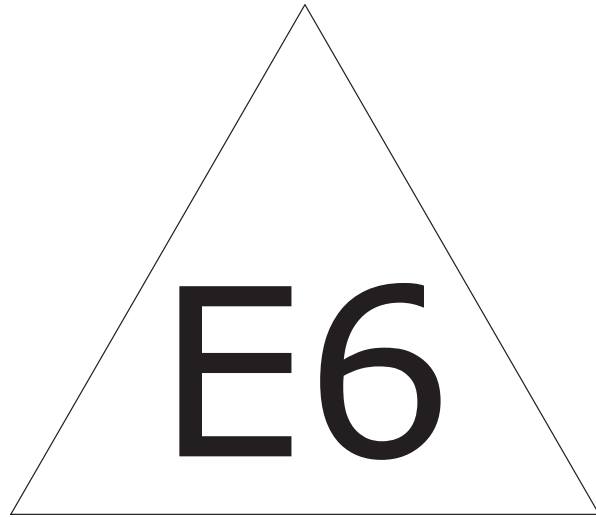

+

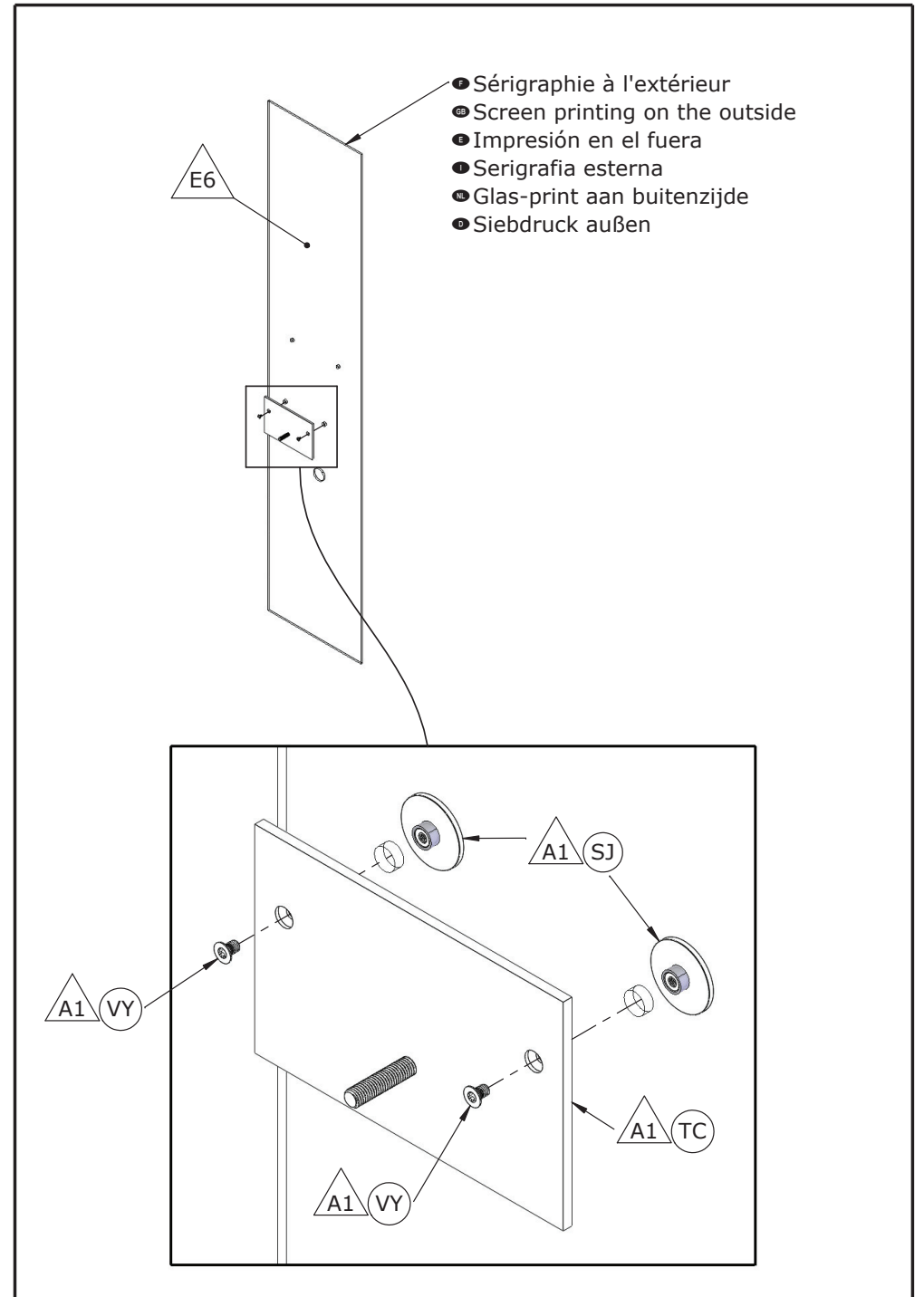

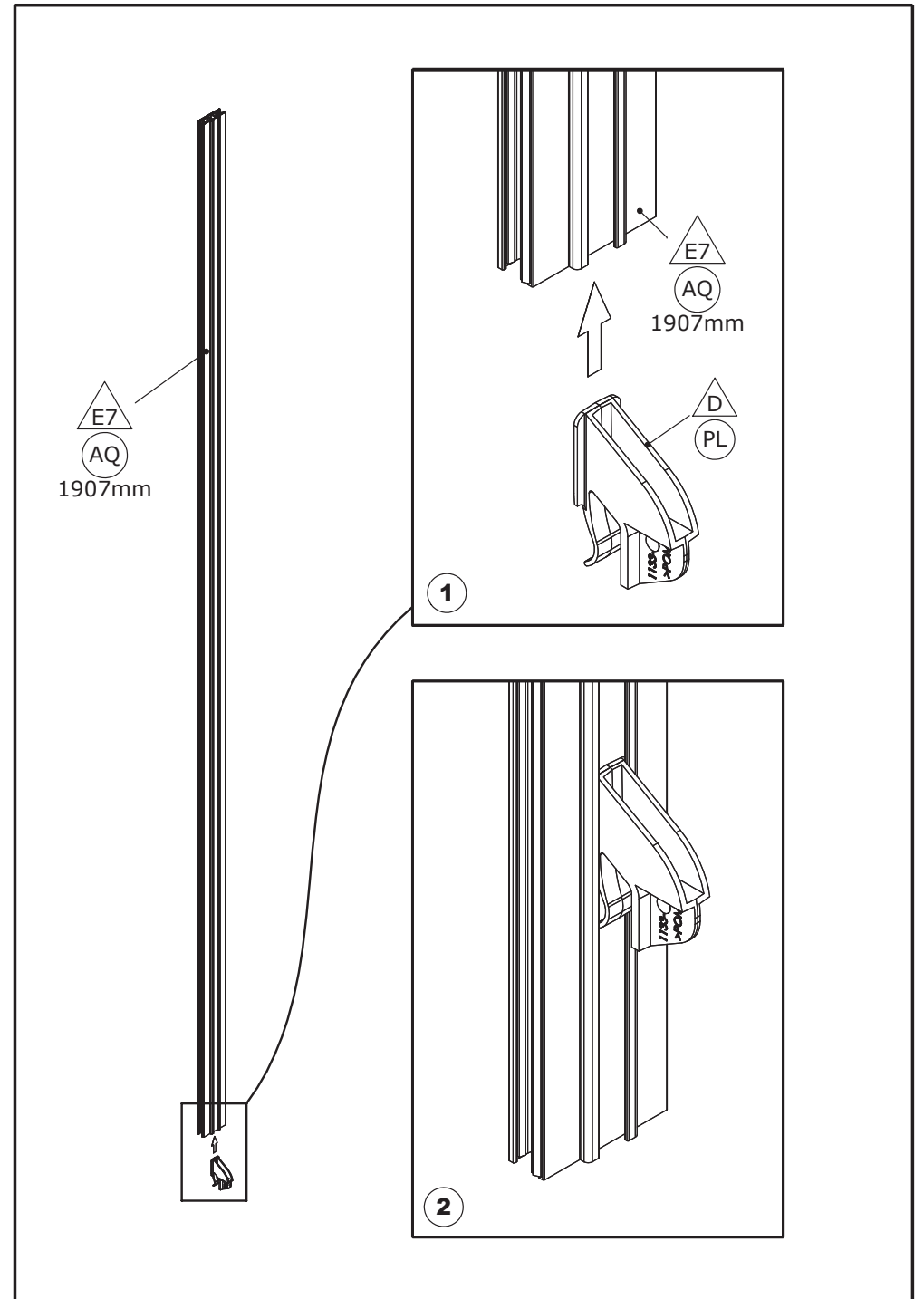
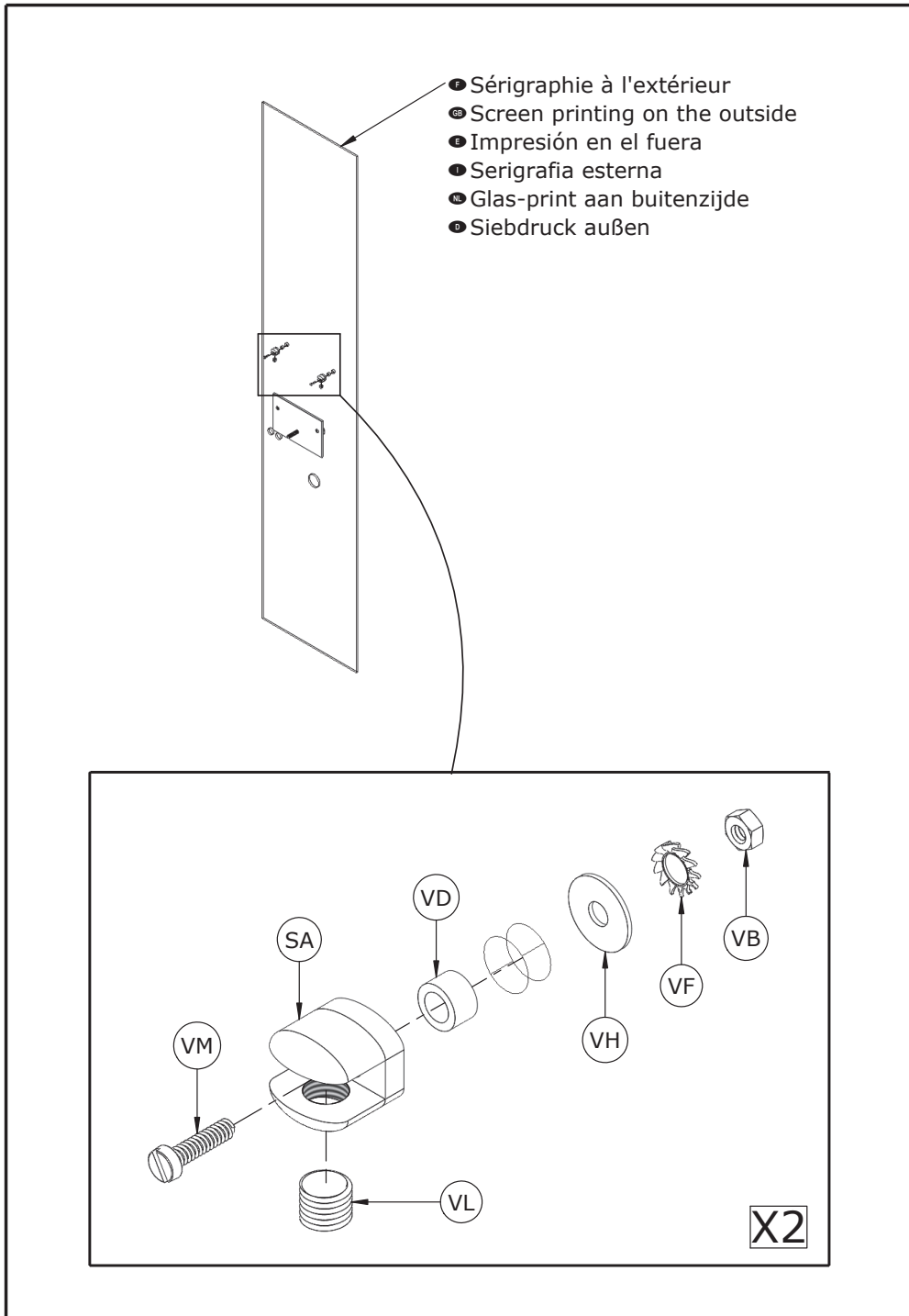

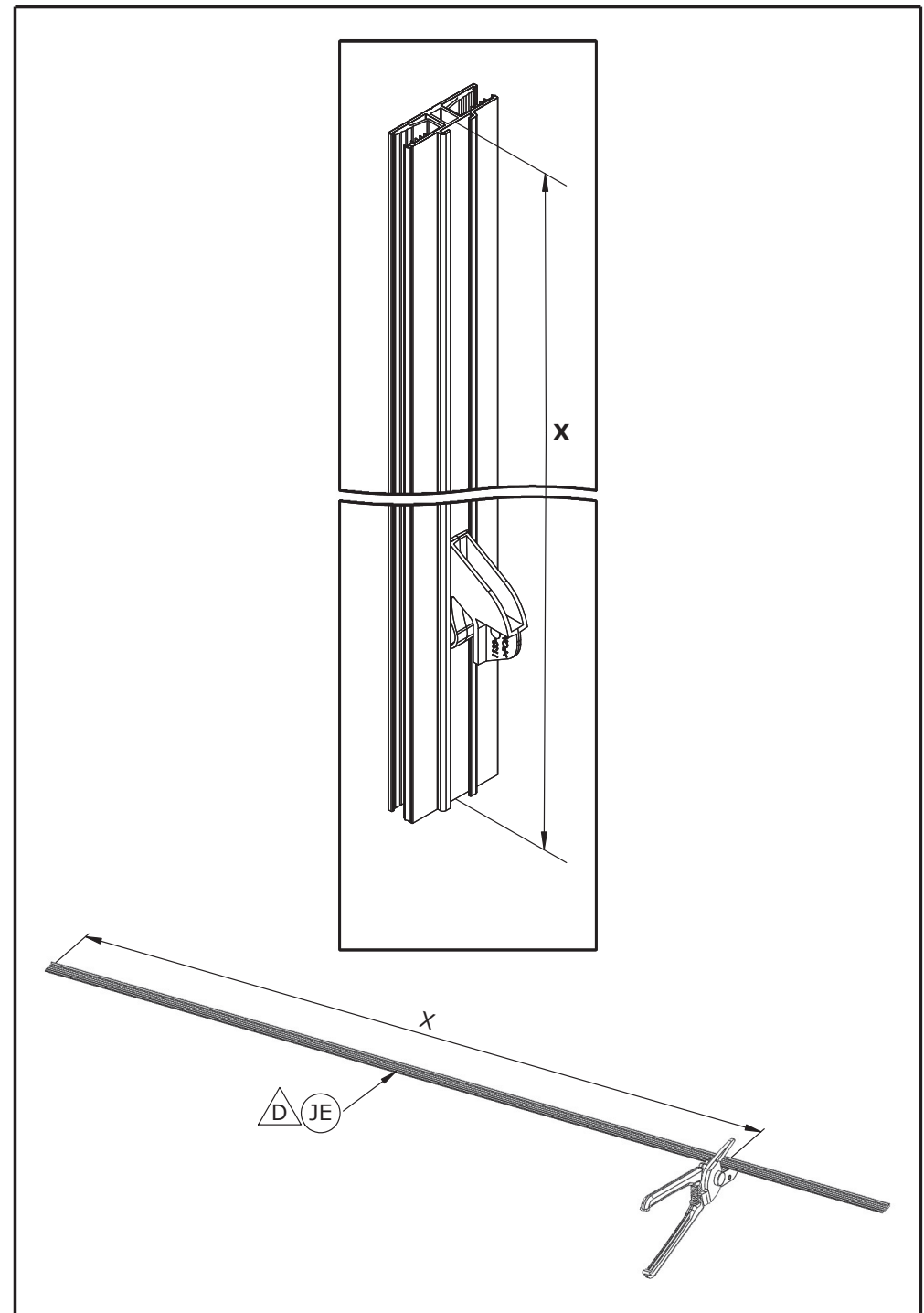
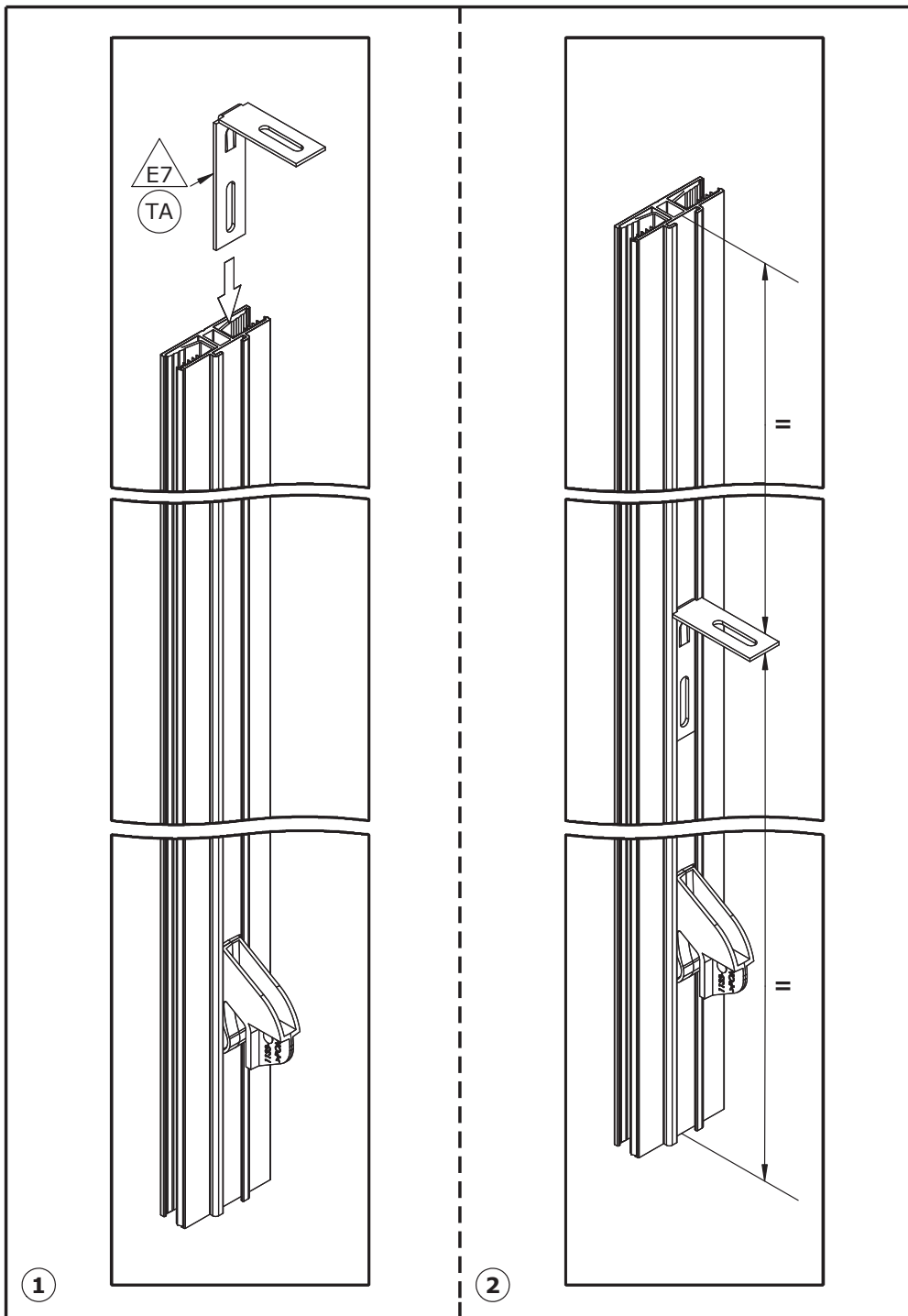

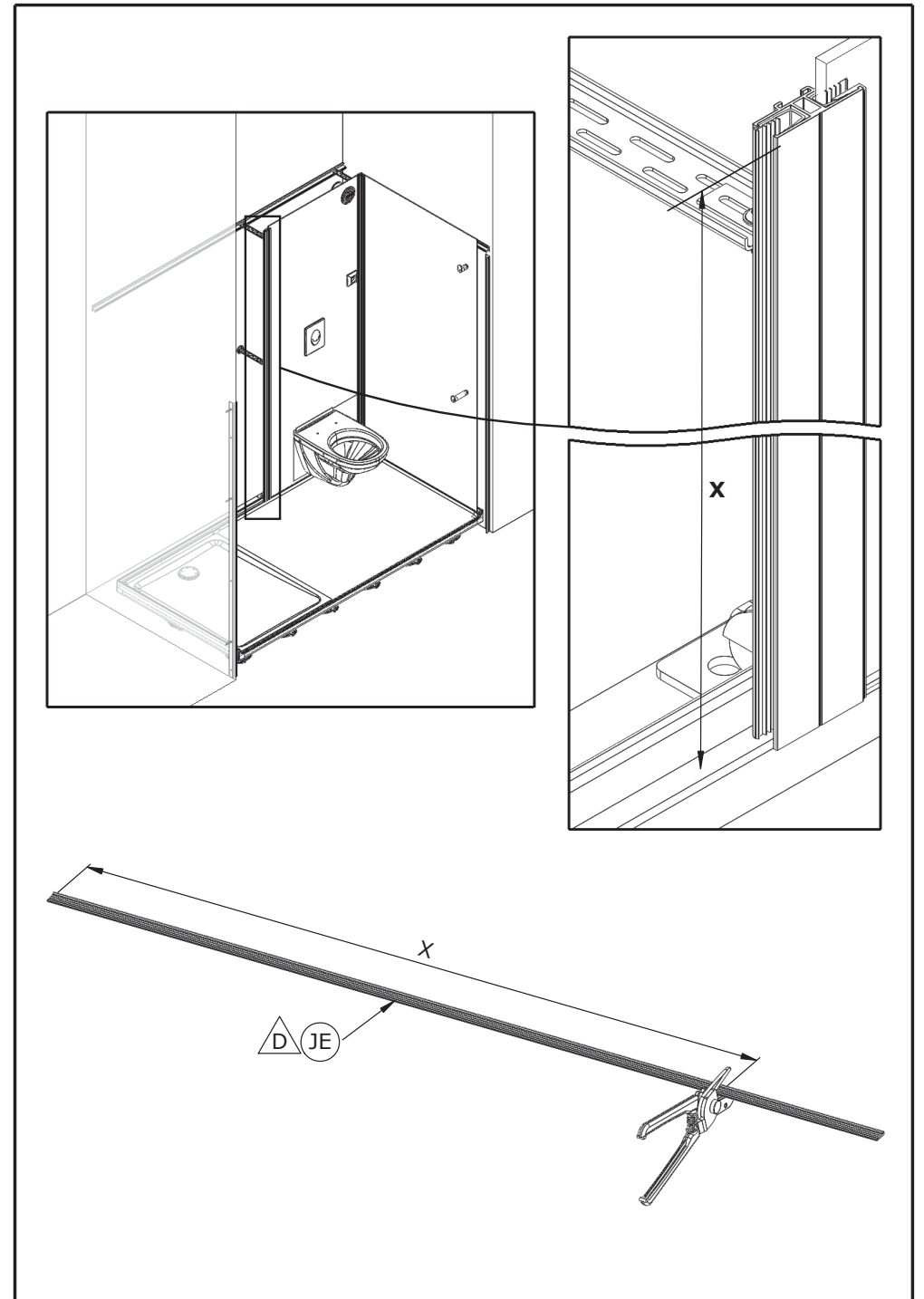
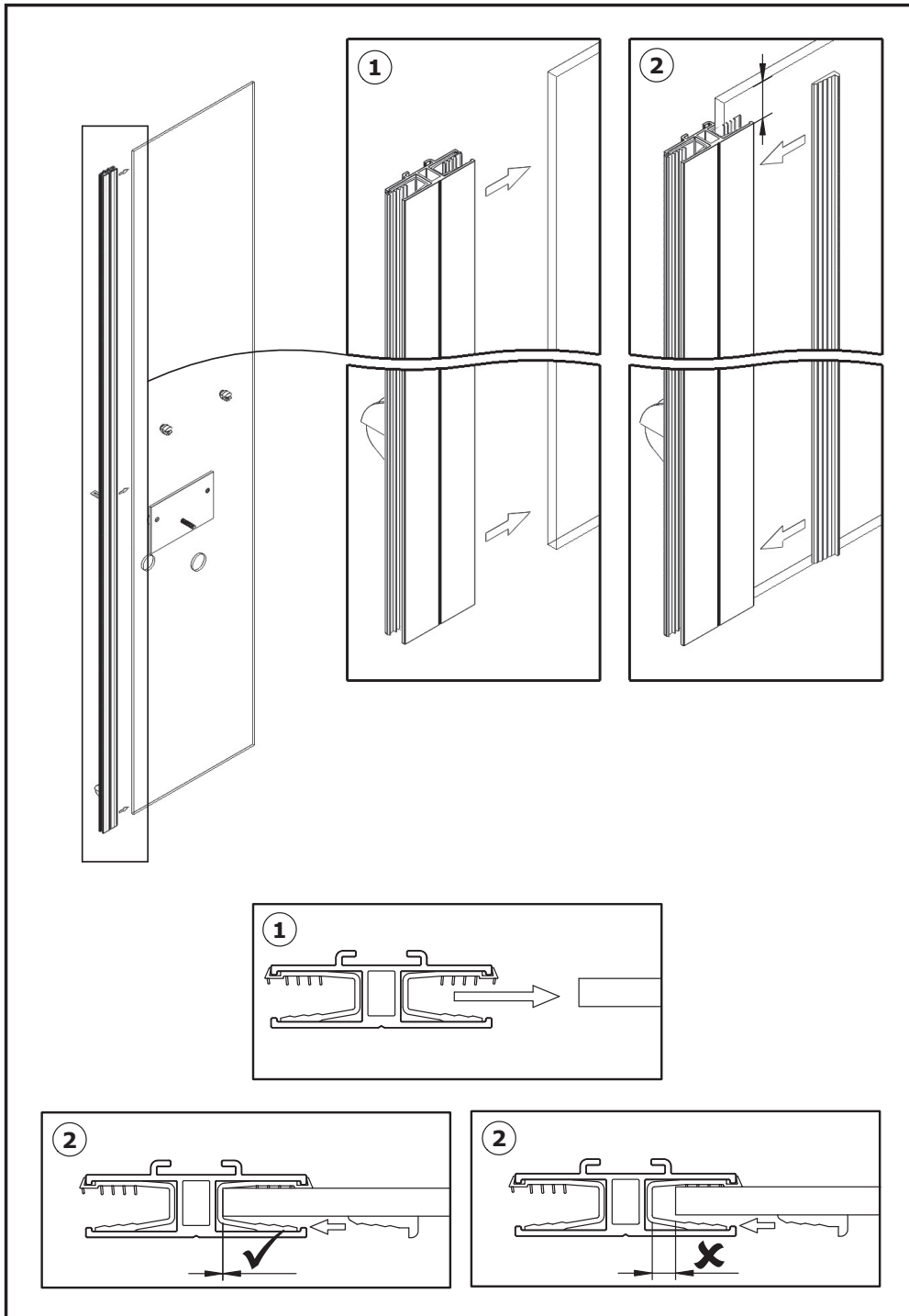

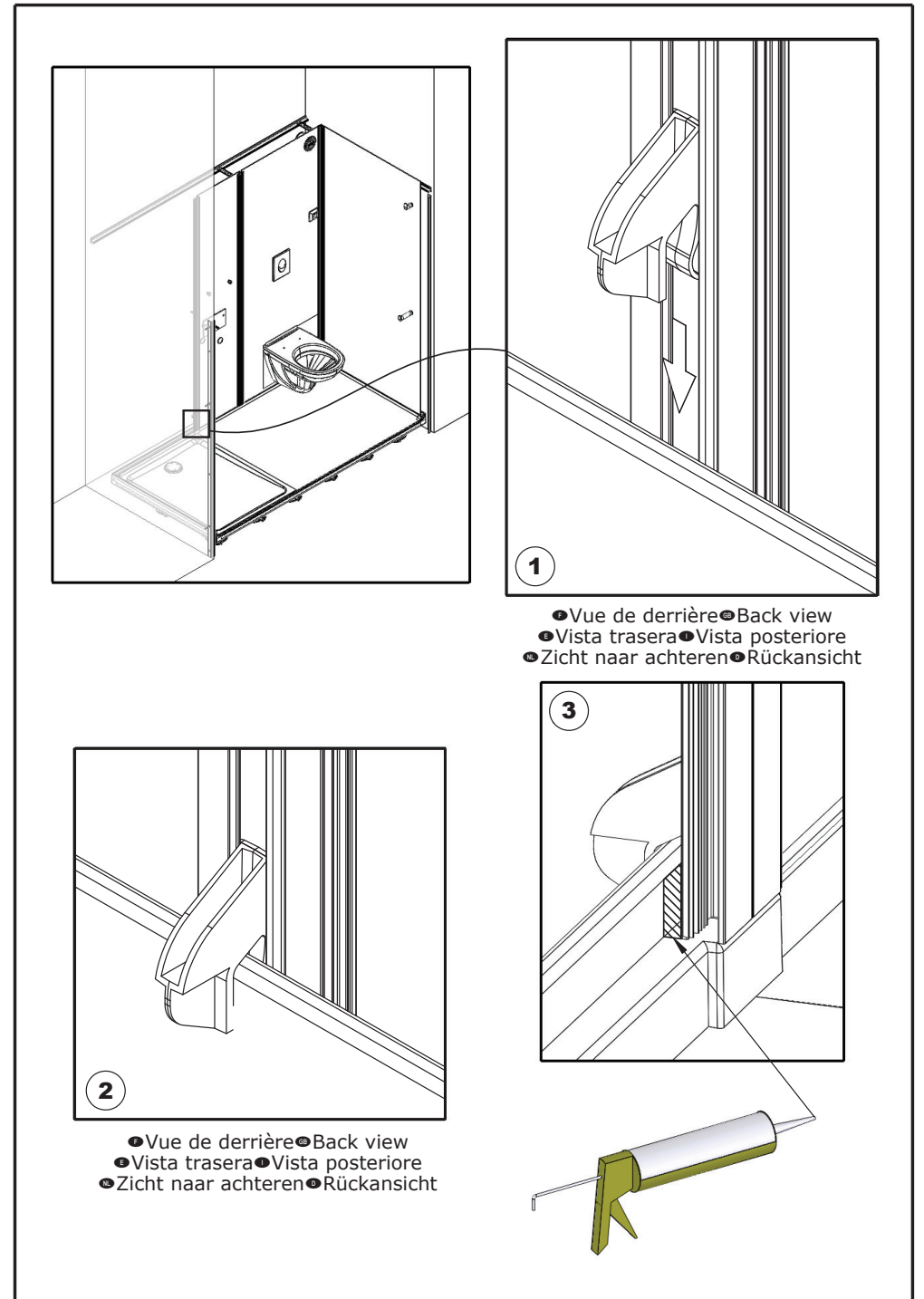
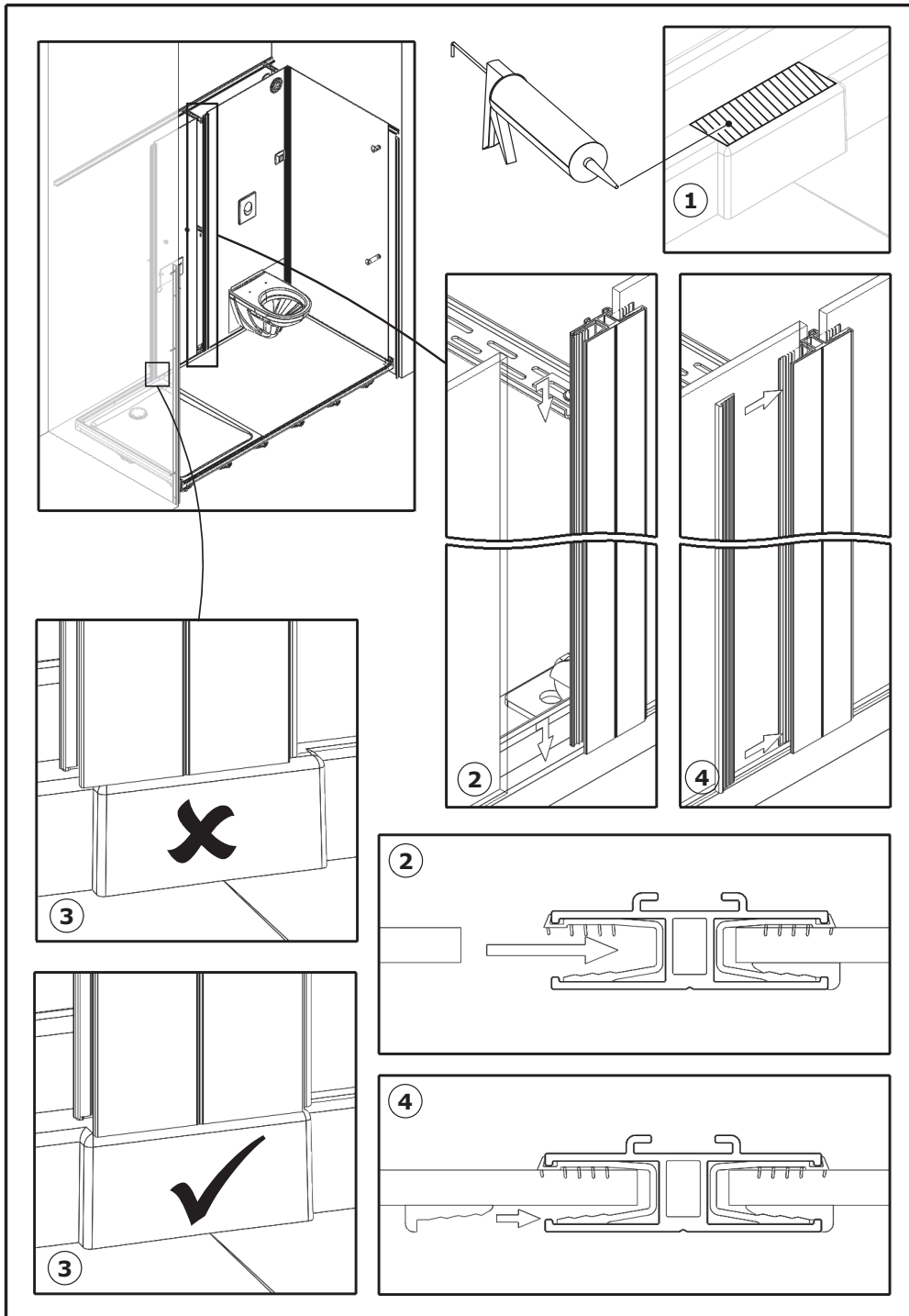

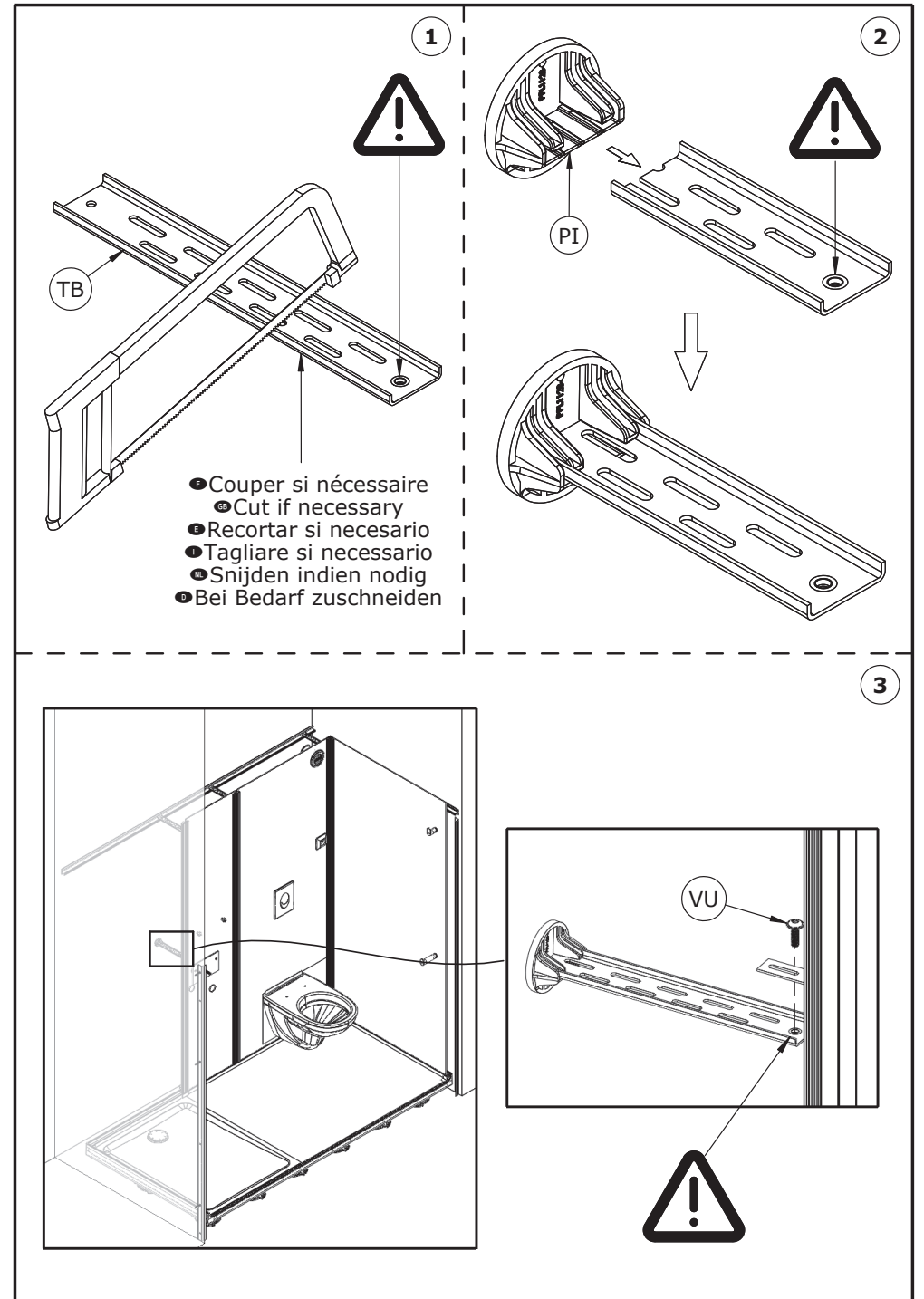
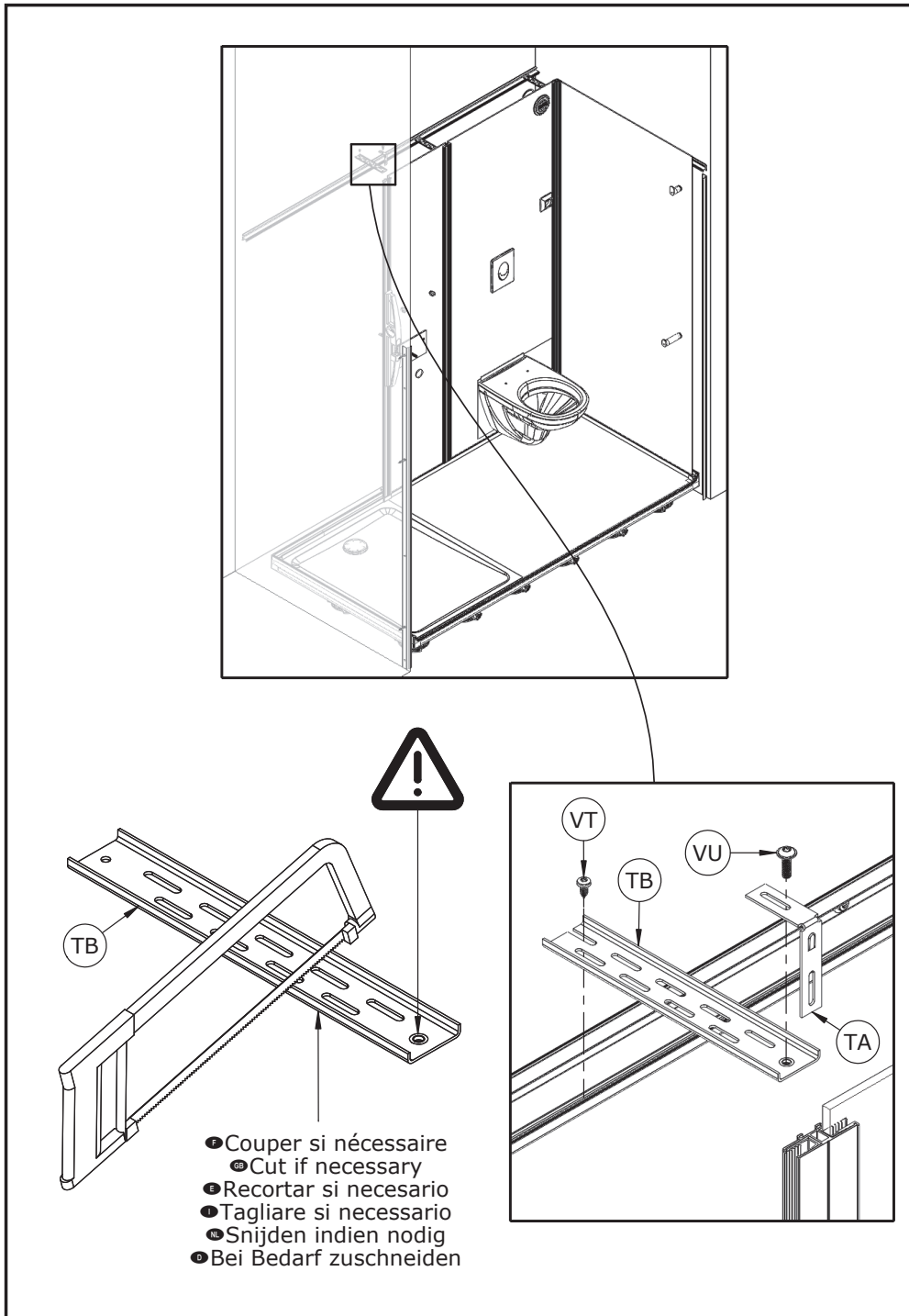

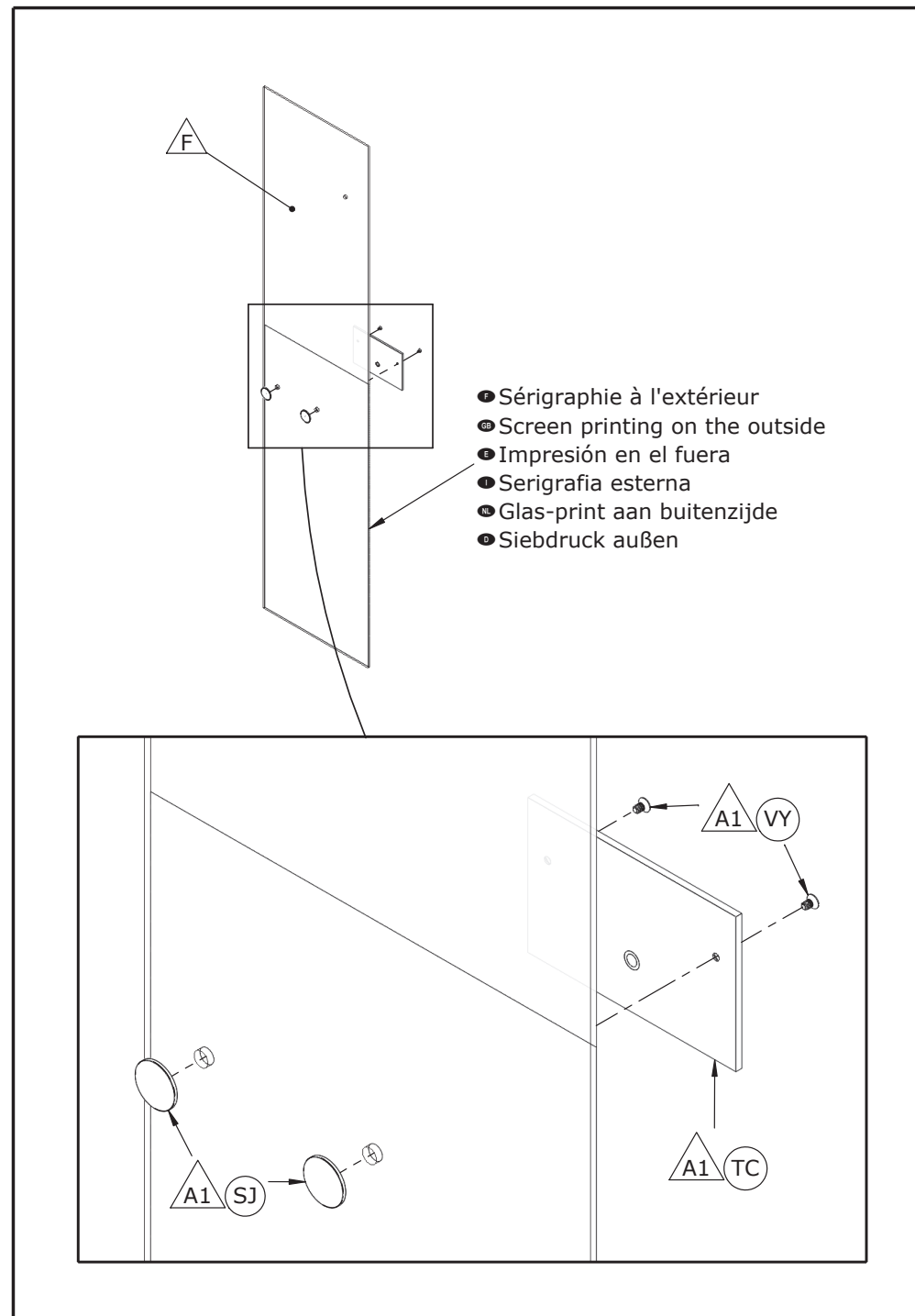
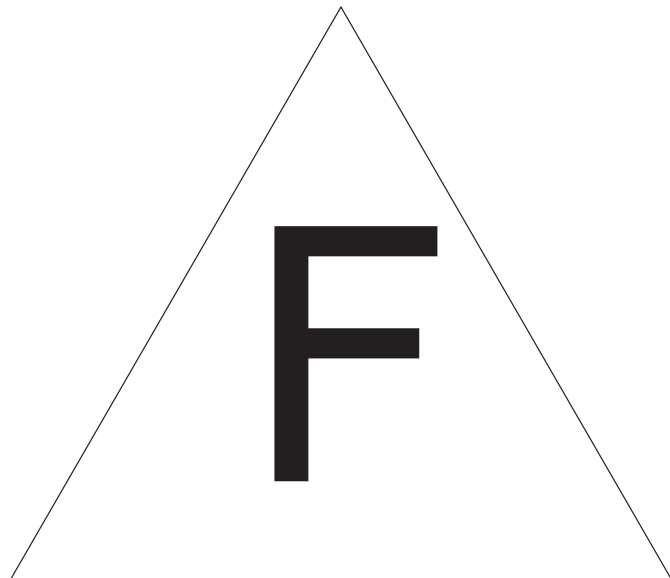

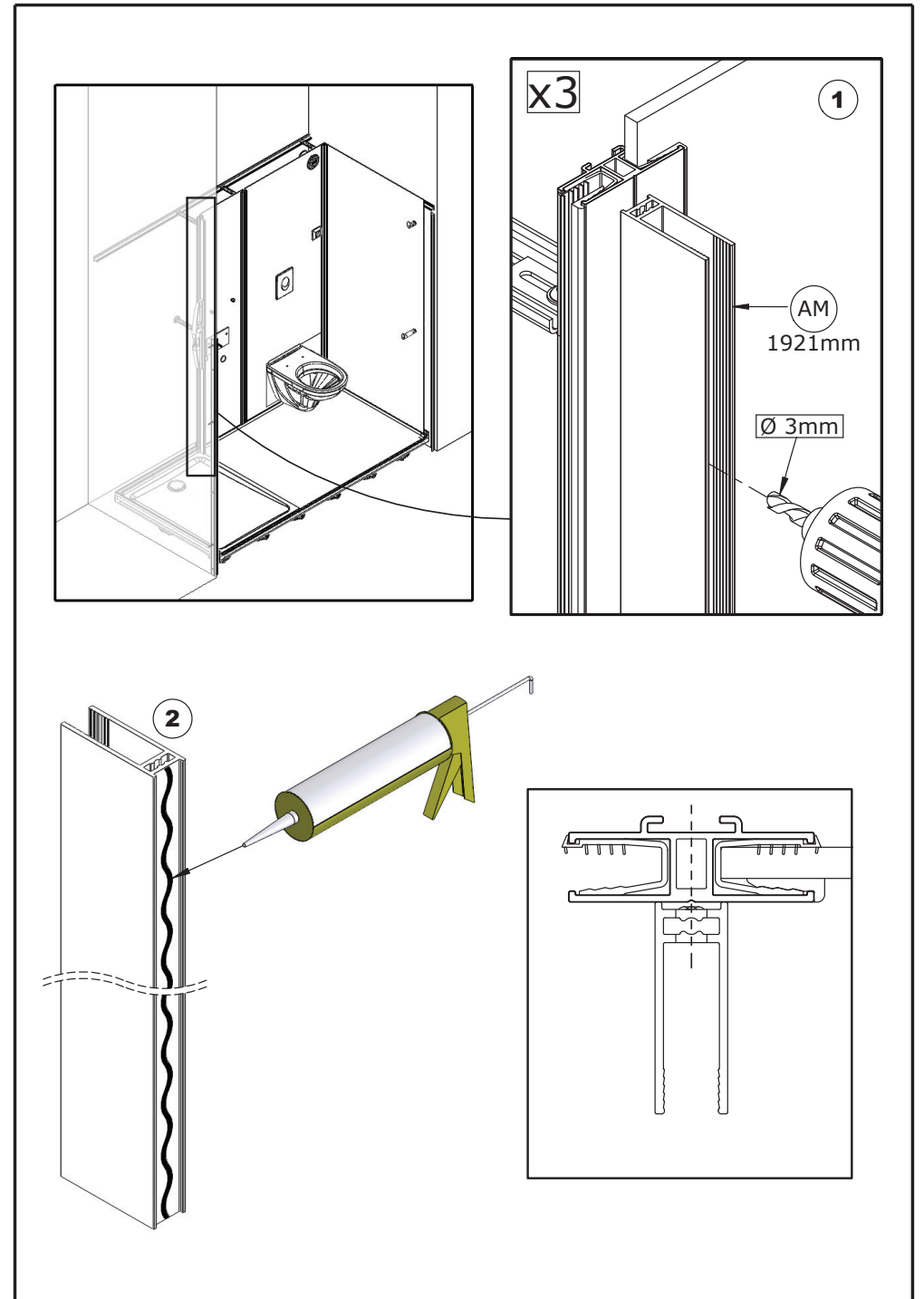
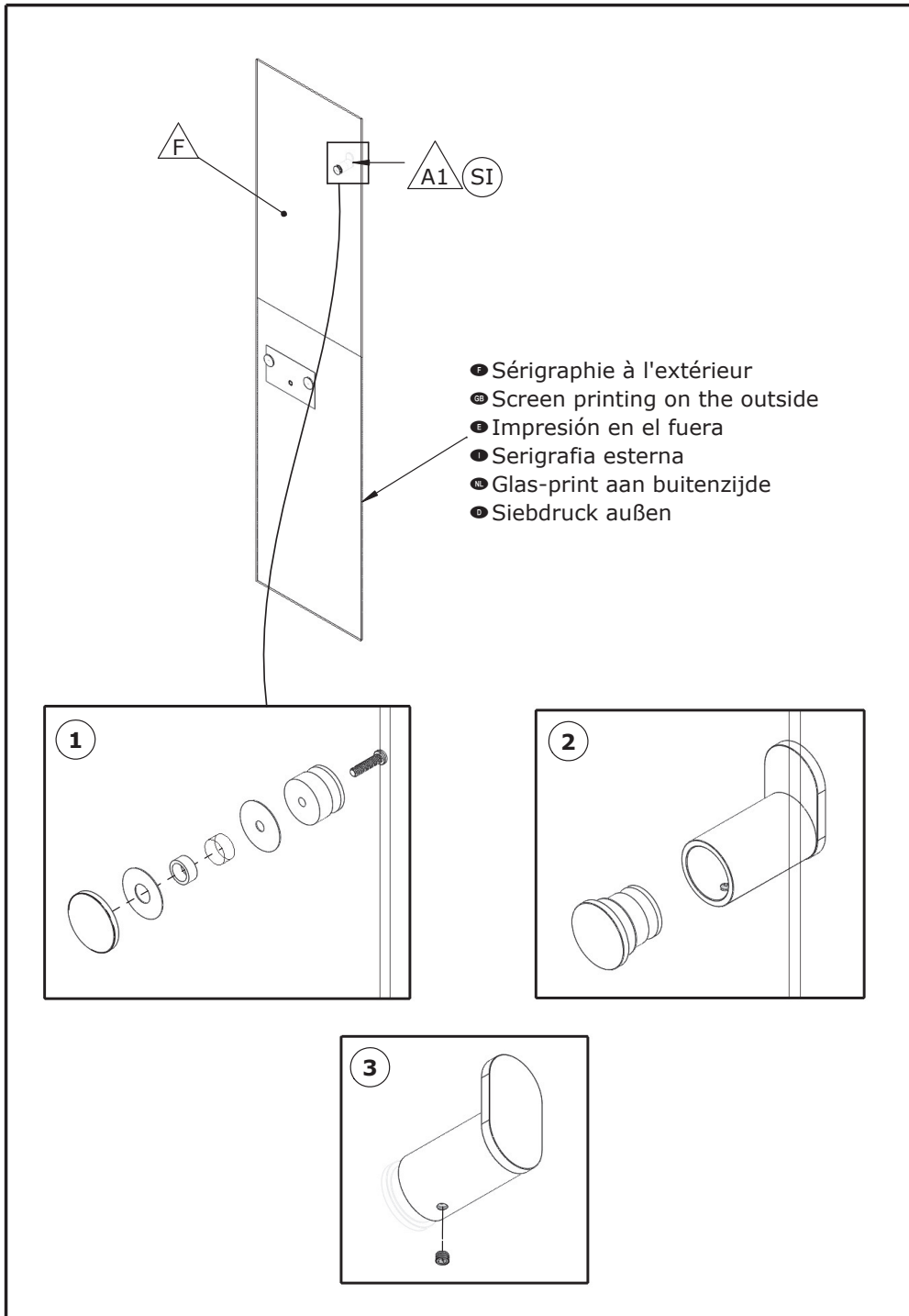

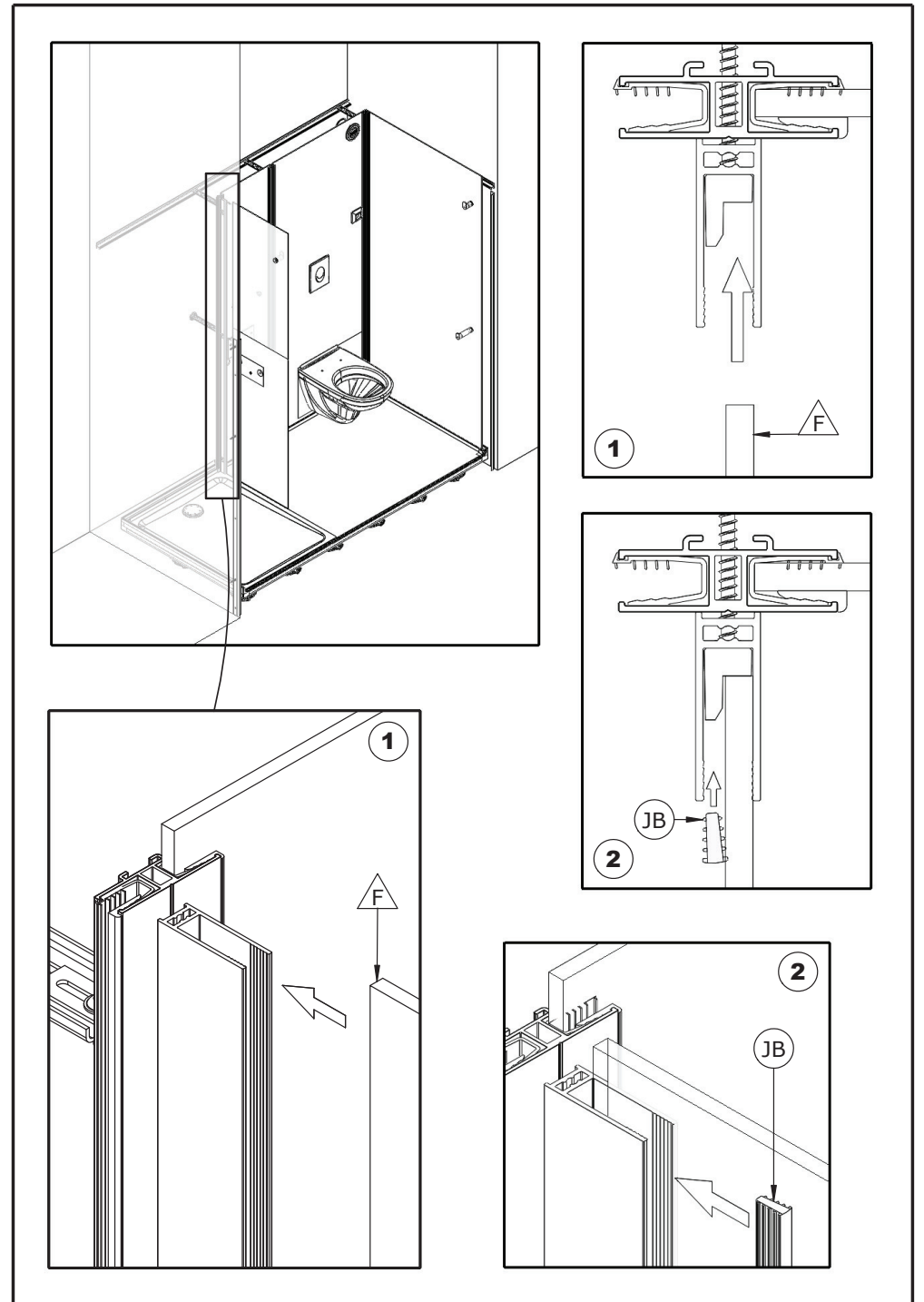
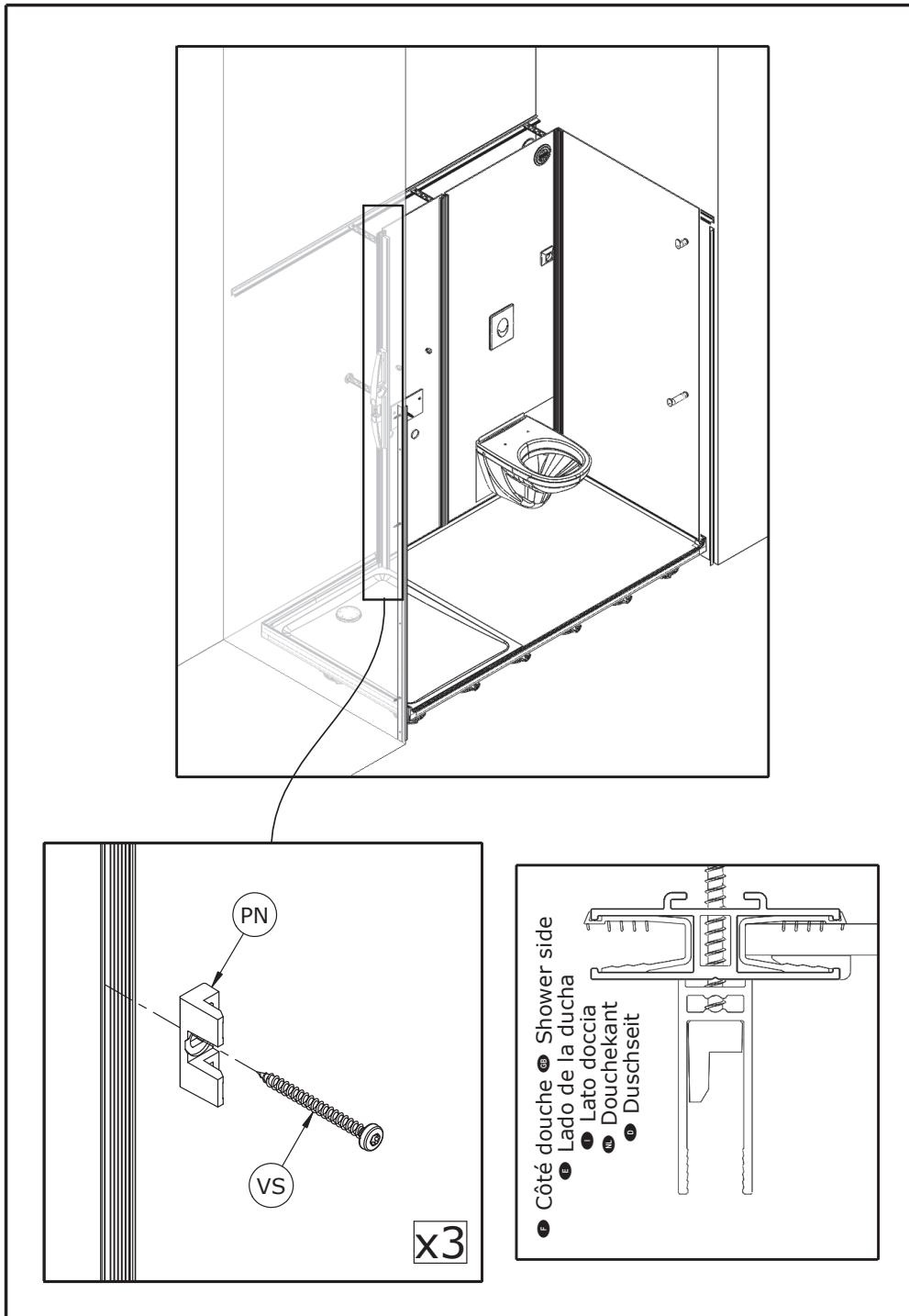

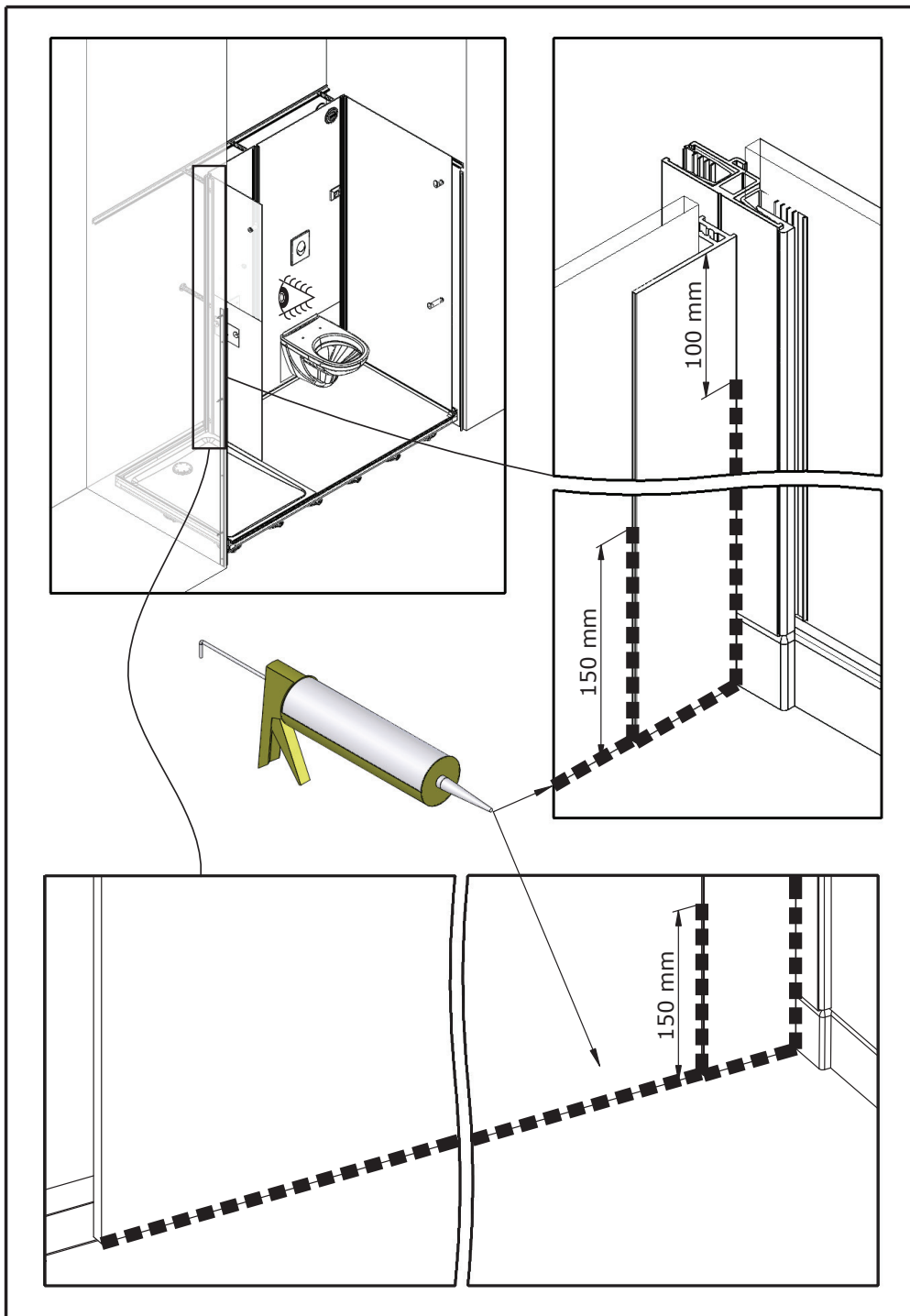

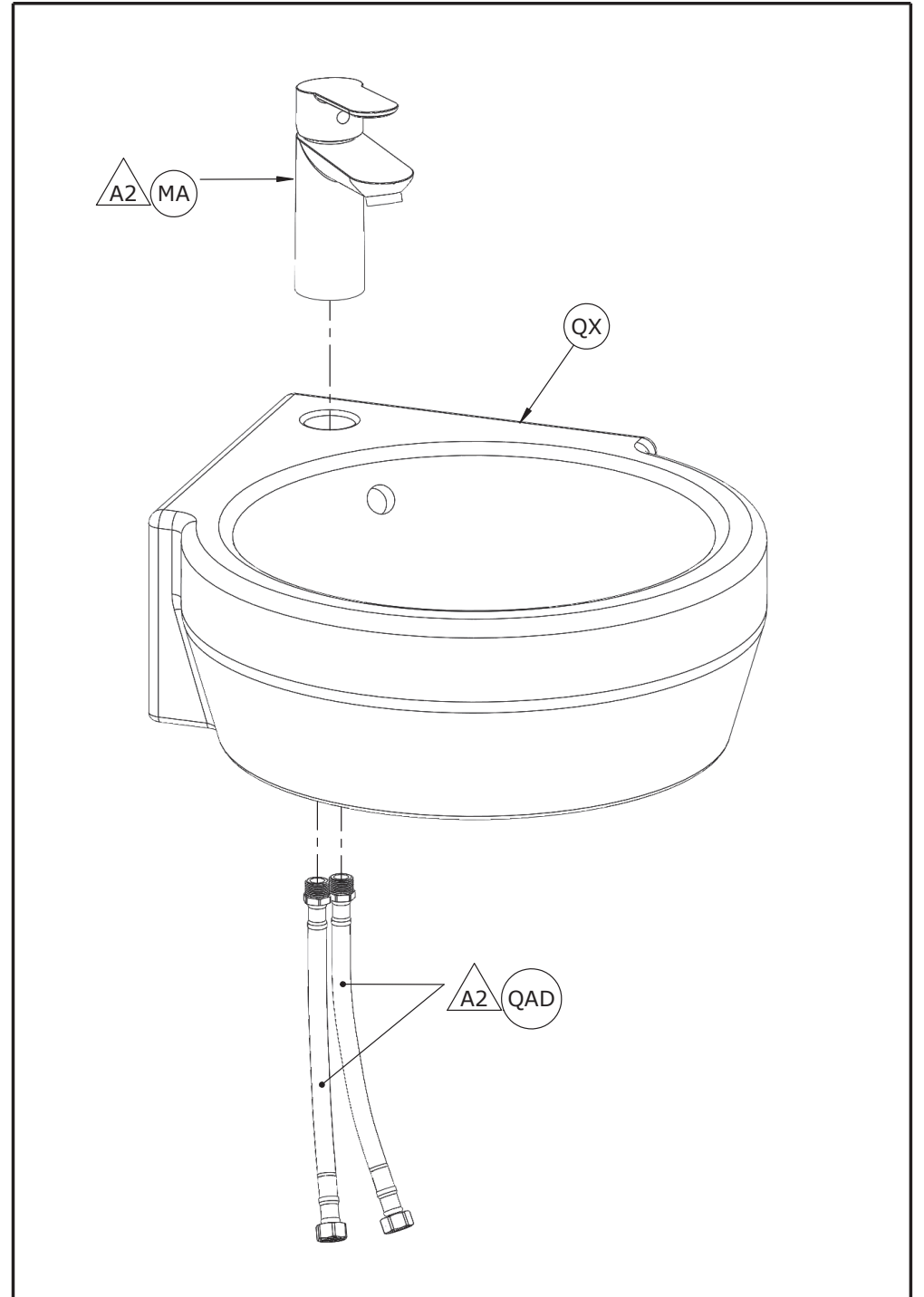

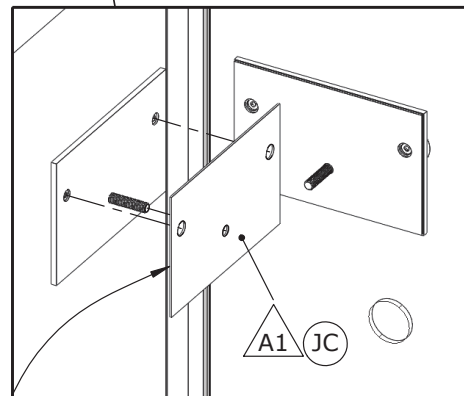
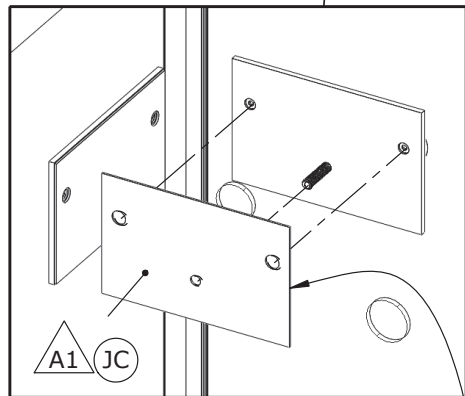
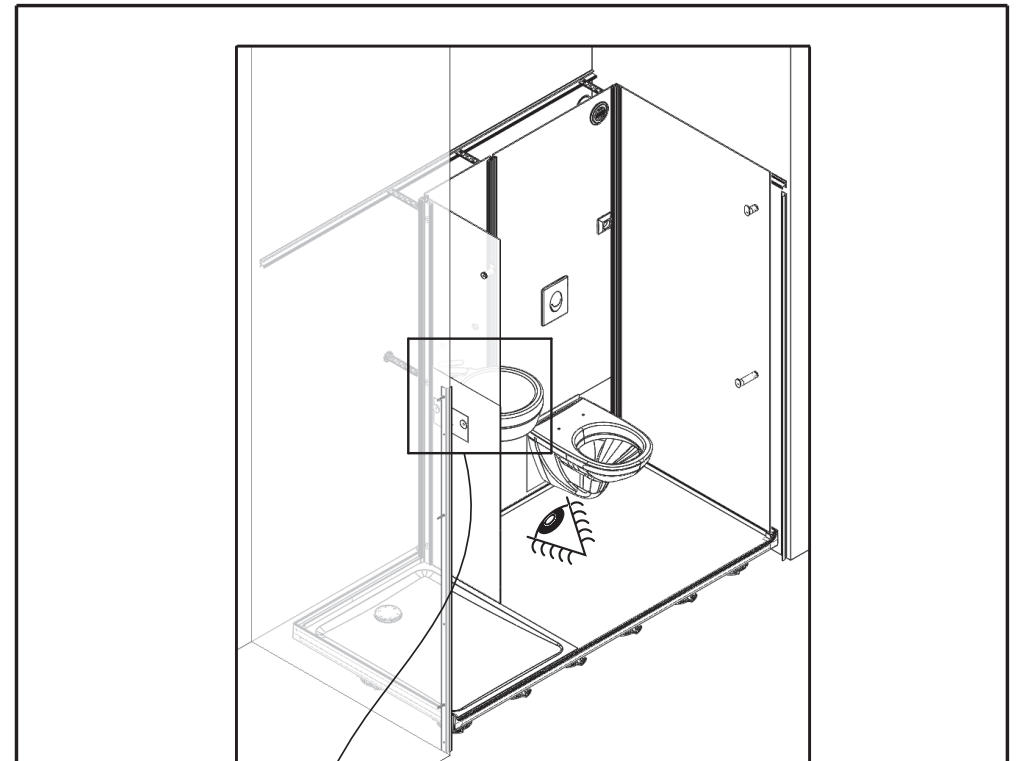
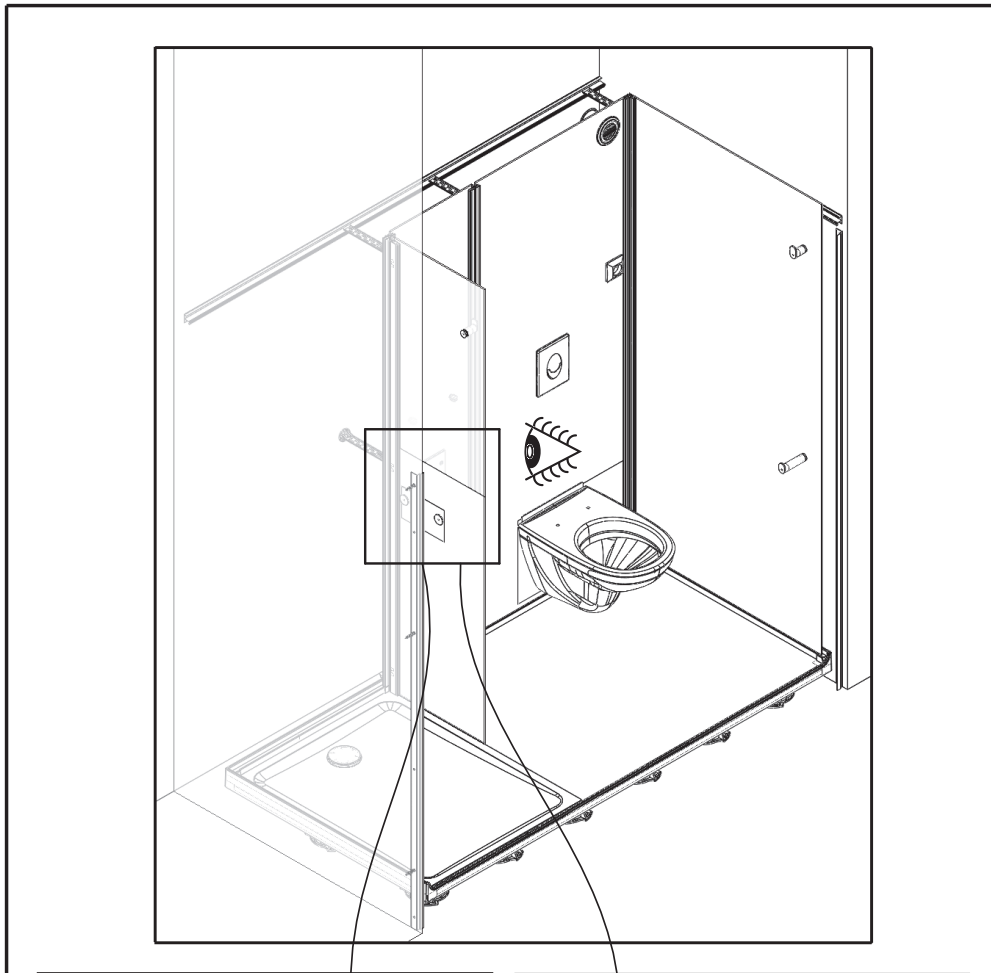

● Enlever liner ● Remove liner ● Quitar liner
 ● Togliere liner ● Verwijderen liner ● Entfernen liner

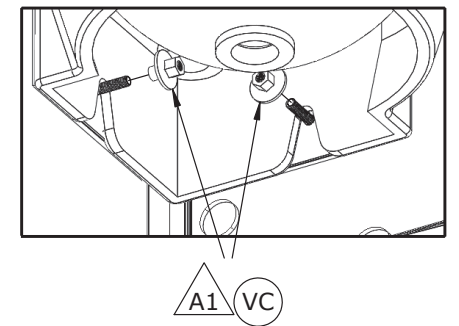
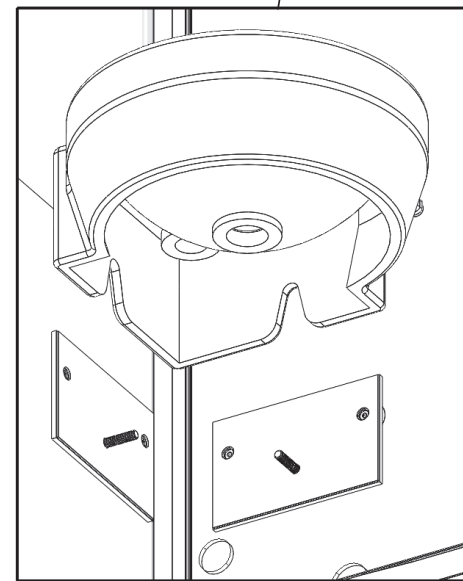

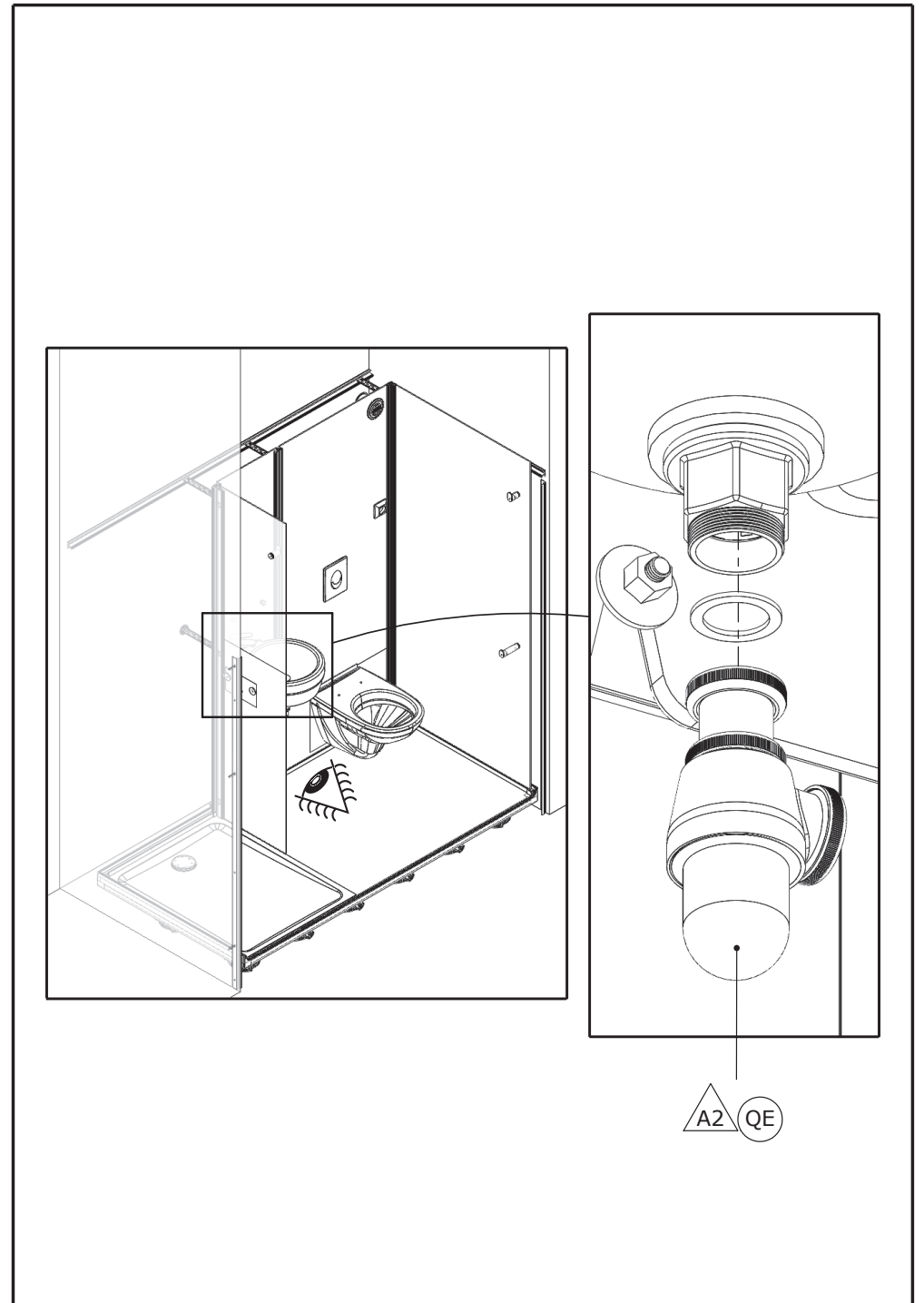
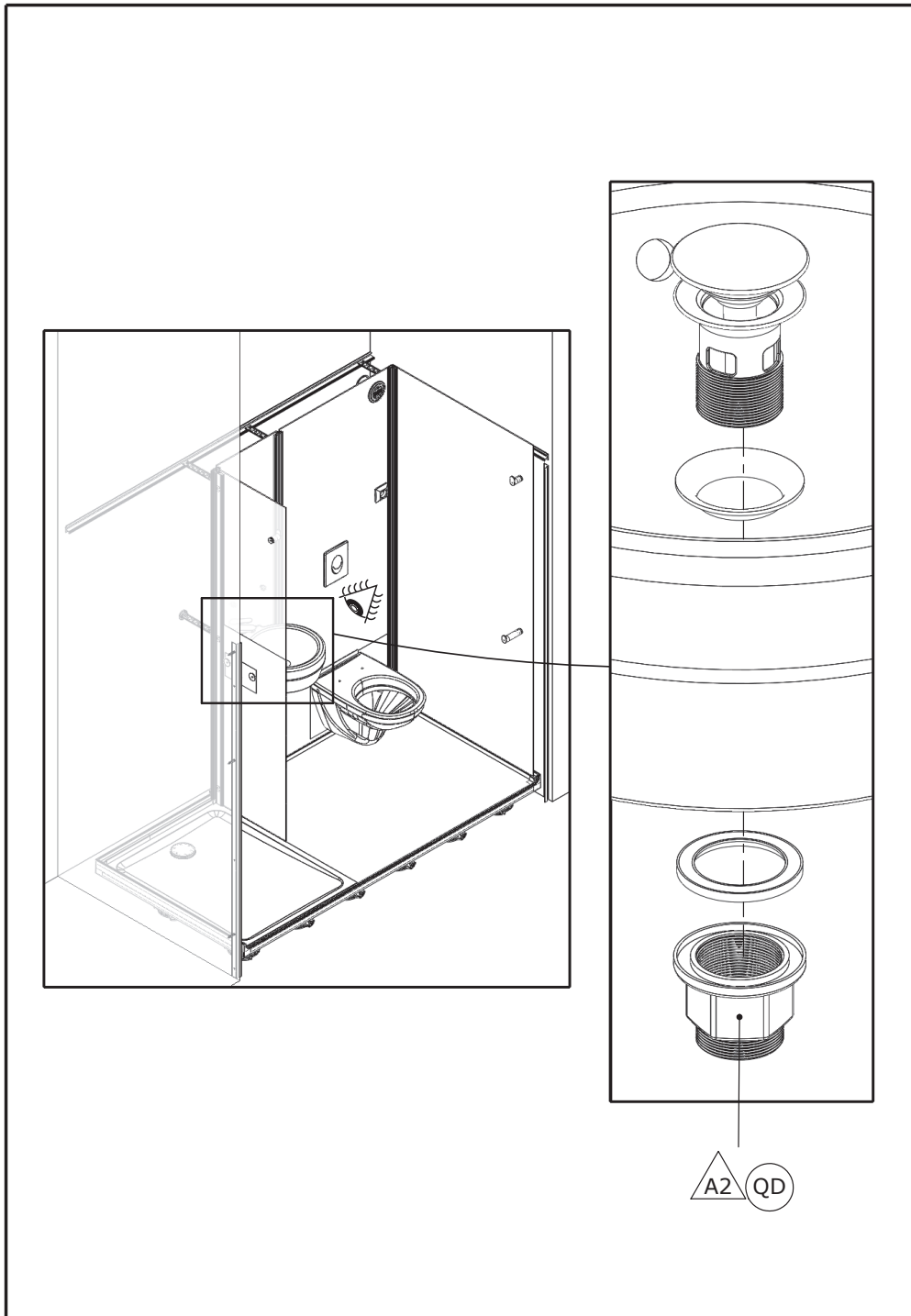

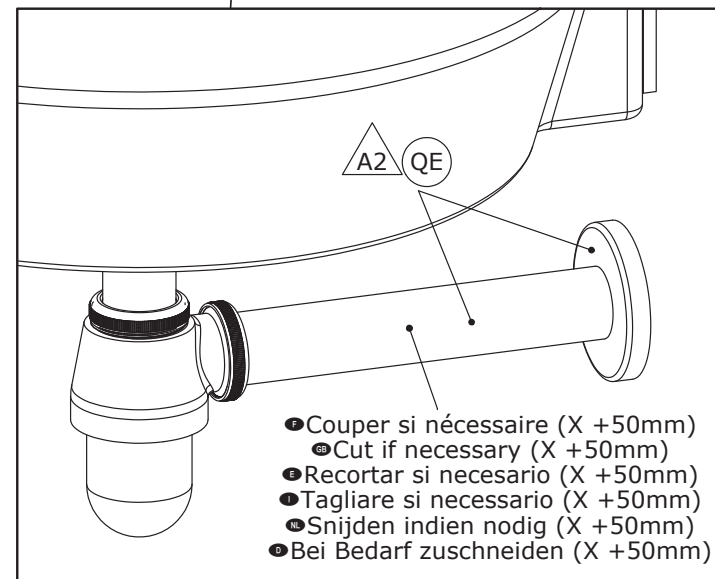
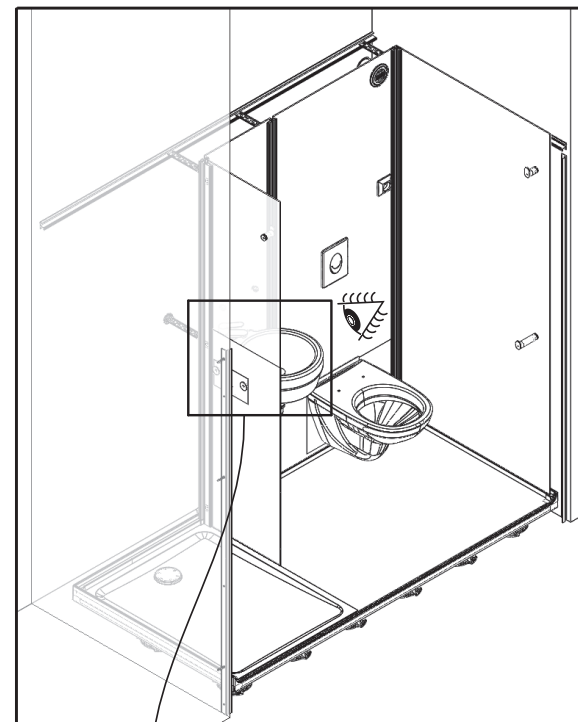
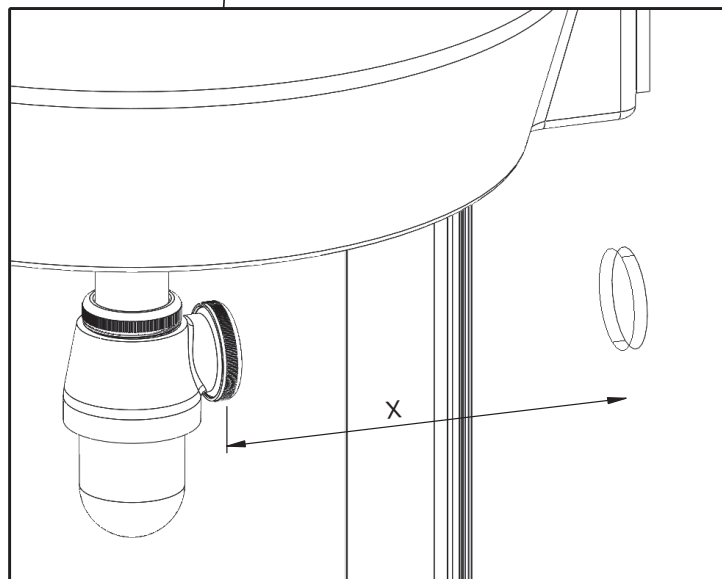
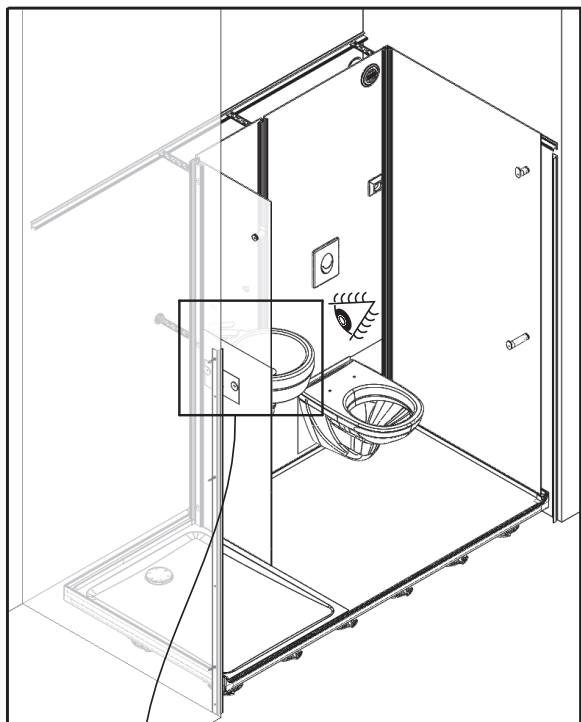

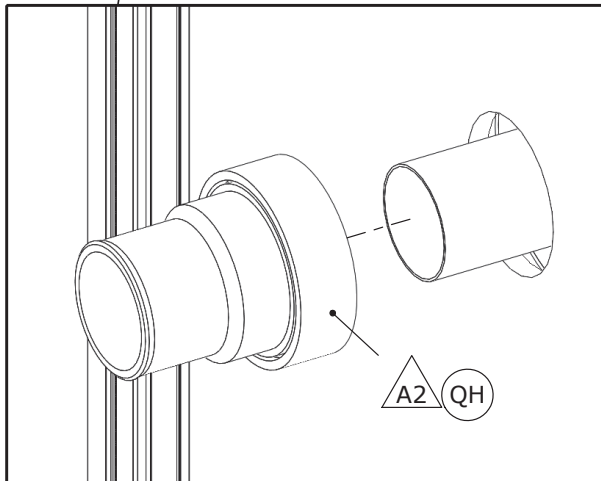
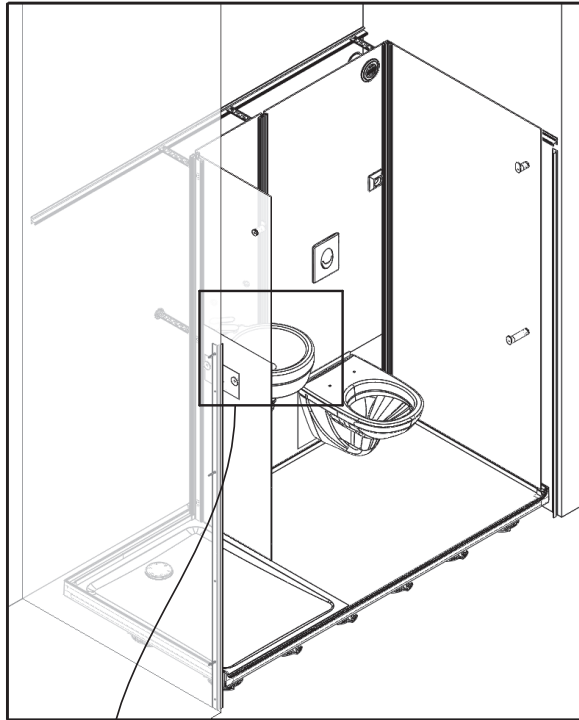

- Vue de derrière • Back view
- Vista trasera • Vista posteriore
- Zicht naar achteren • Rückansicht

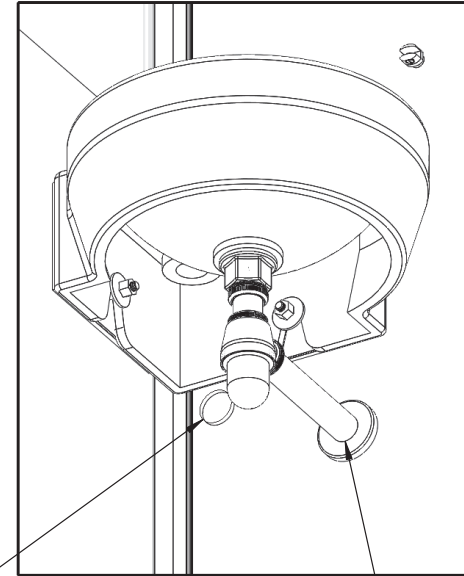

2

- Raccordement alimentation
- Power supply connection
- Conexión de la fuente de alimentación
- Collegamento all'alimentazione
- Aansluiting op de stroomvoorziening
- Anschluss der Stromversorgung

1

- Raccordement évacuation
- Drain connection
- Conexión de drenaje
- Collegamento dello scarico
- Afvoeraansluiting
- Entleerungsanschluss

3

- Effectuer un test en eau avant de poursuivre le montage
- Perform a water test before continuing with the assembly
- Realice una prueba de agua antes de continuar con el montaje
- Eseguire un test dell'acqua prima di continuare con l'assemblaggio
- Voer een watertest uit voordat u verder gaat met de montage
- Führen Sie einen Wassertest durch, bevor Sie mit der Montage fortfahren

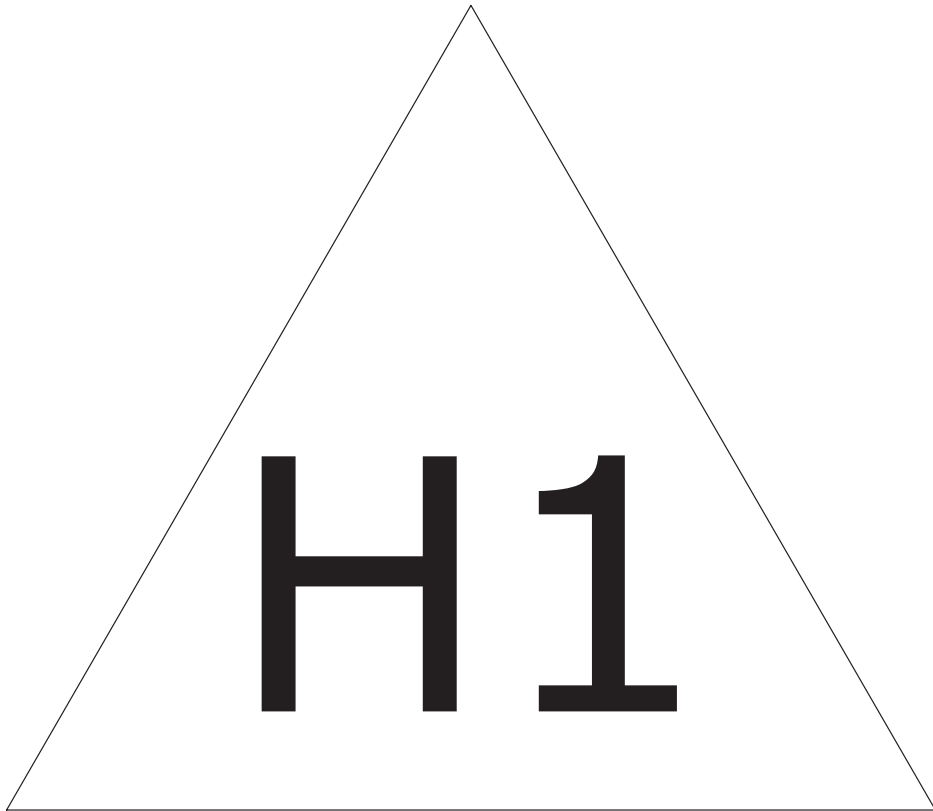

- Sérigraphie à l'extérieur
- Screen printing on the outside
- Impresión en el fuera
- Serigrafia esterna
- Glas-print aan buitenzijde
- Siebdruck außen

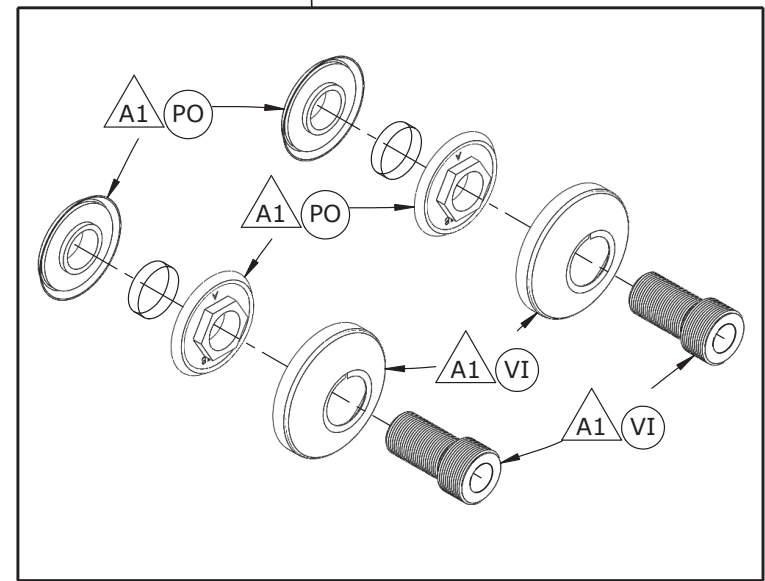
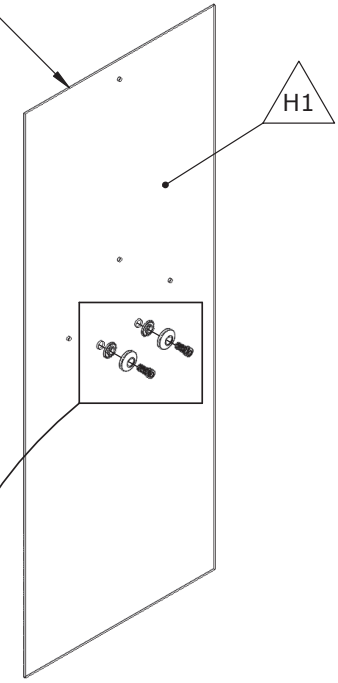

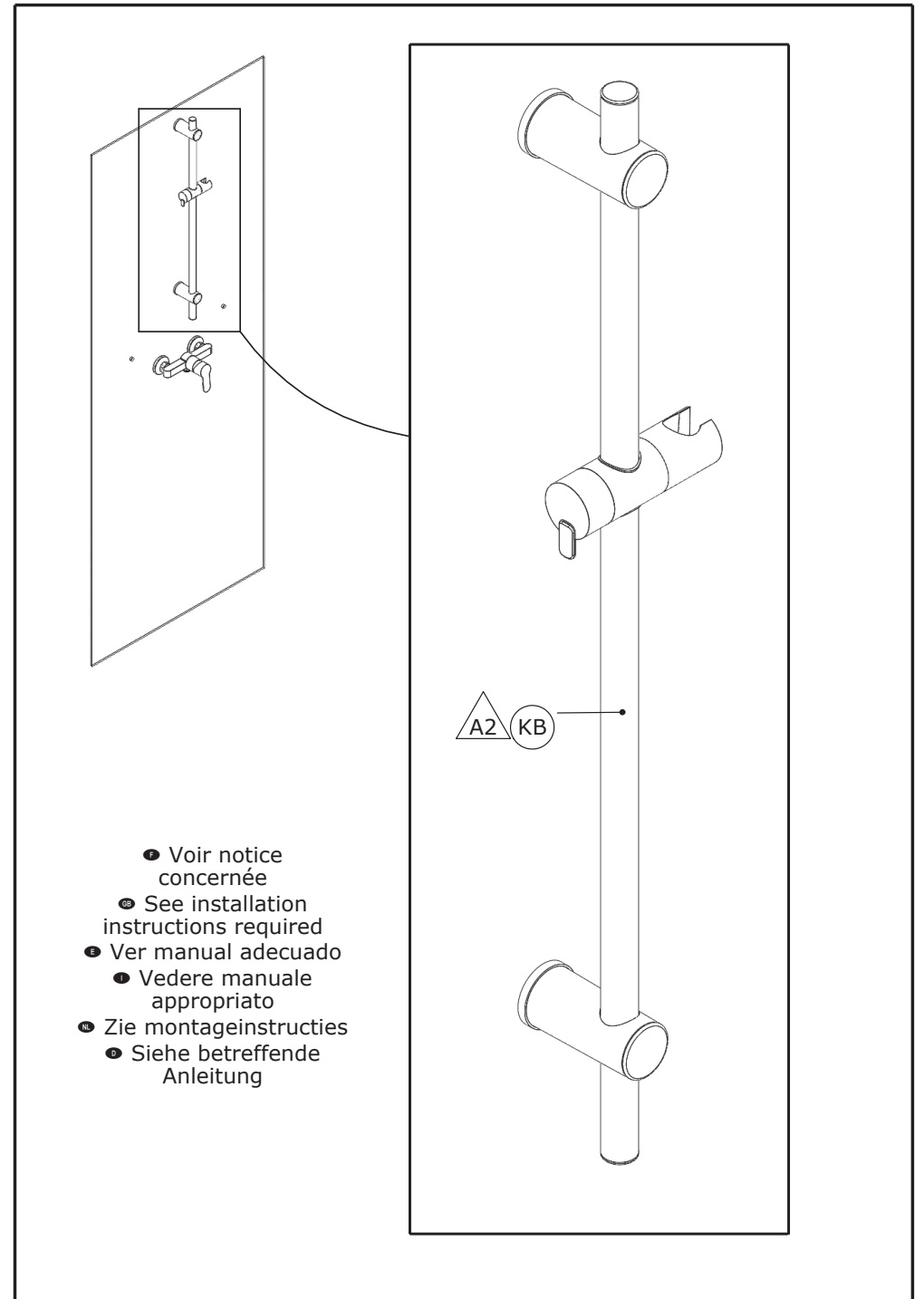
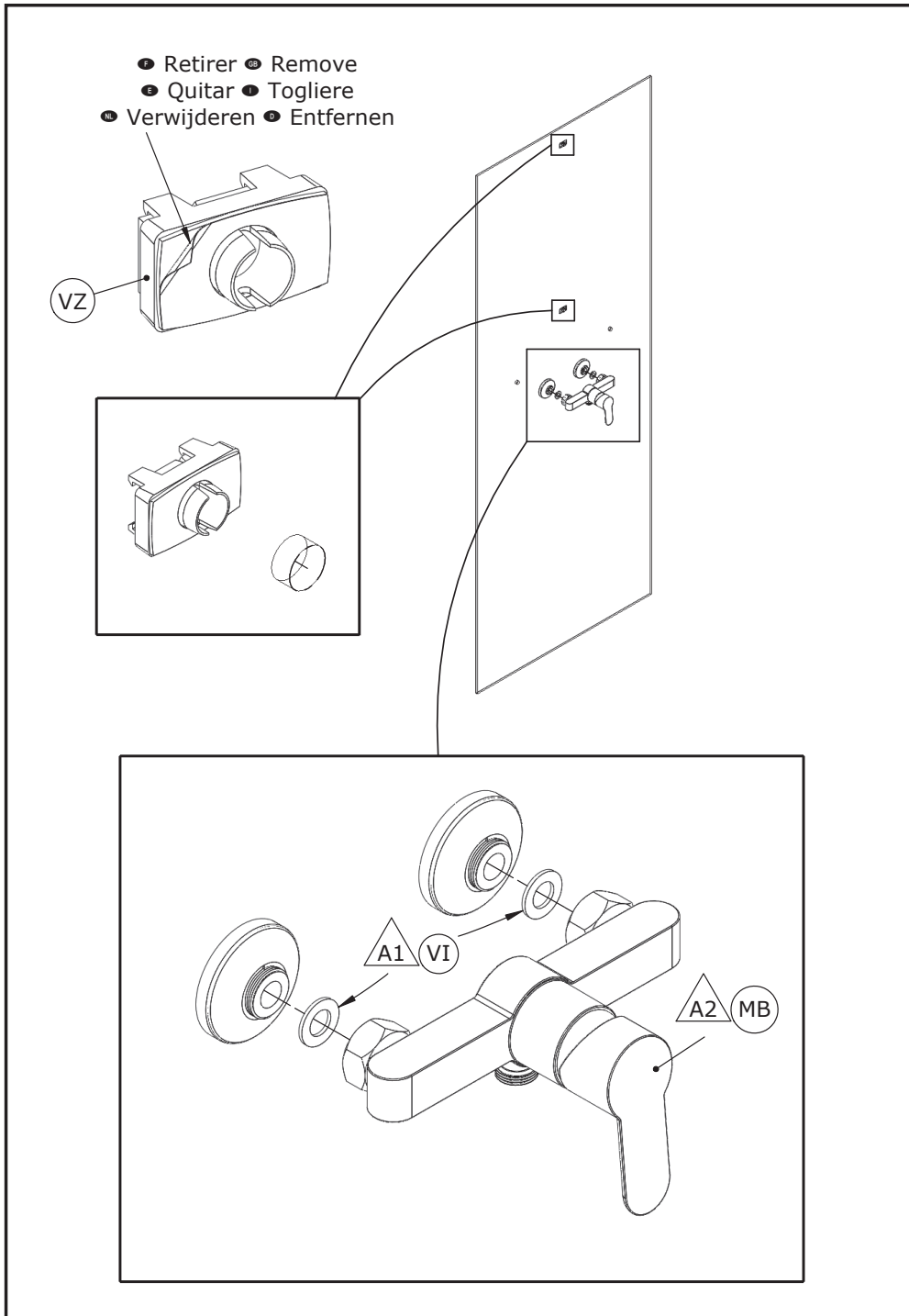

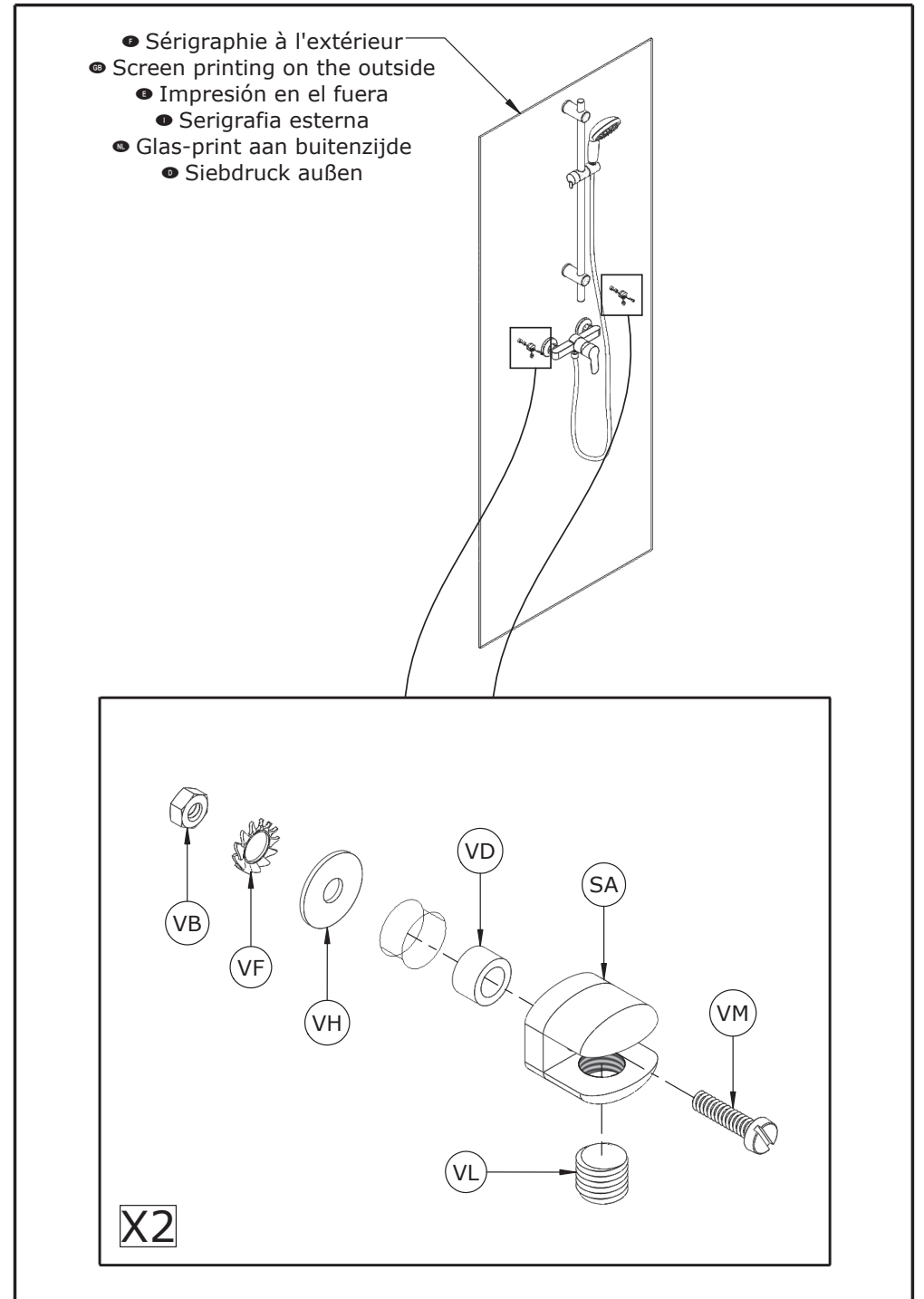
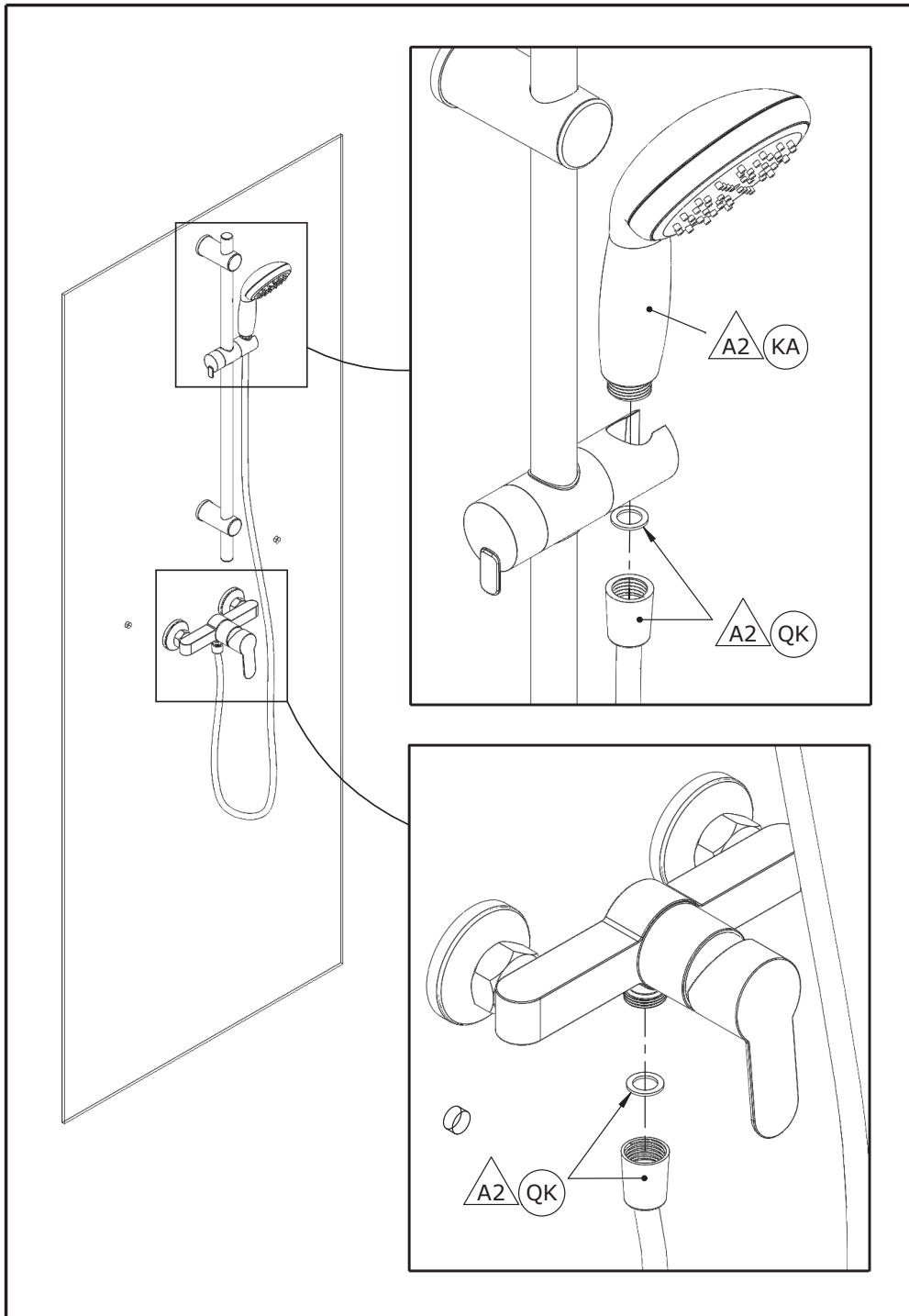

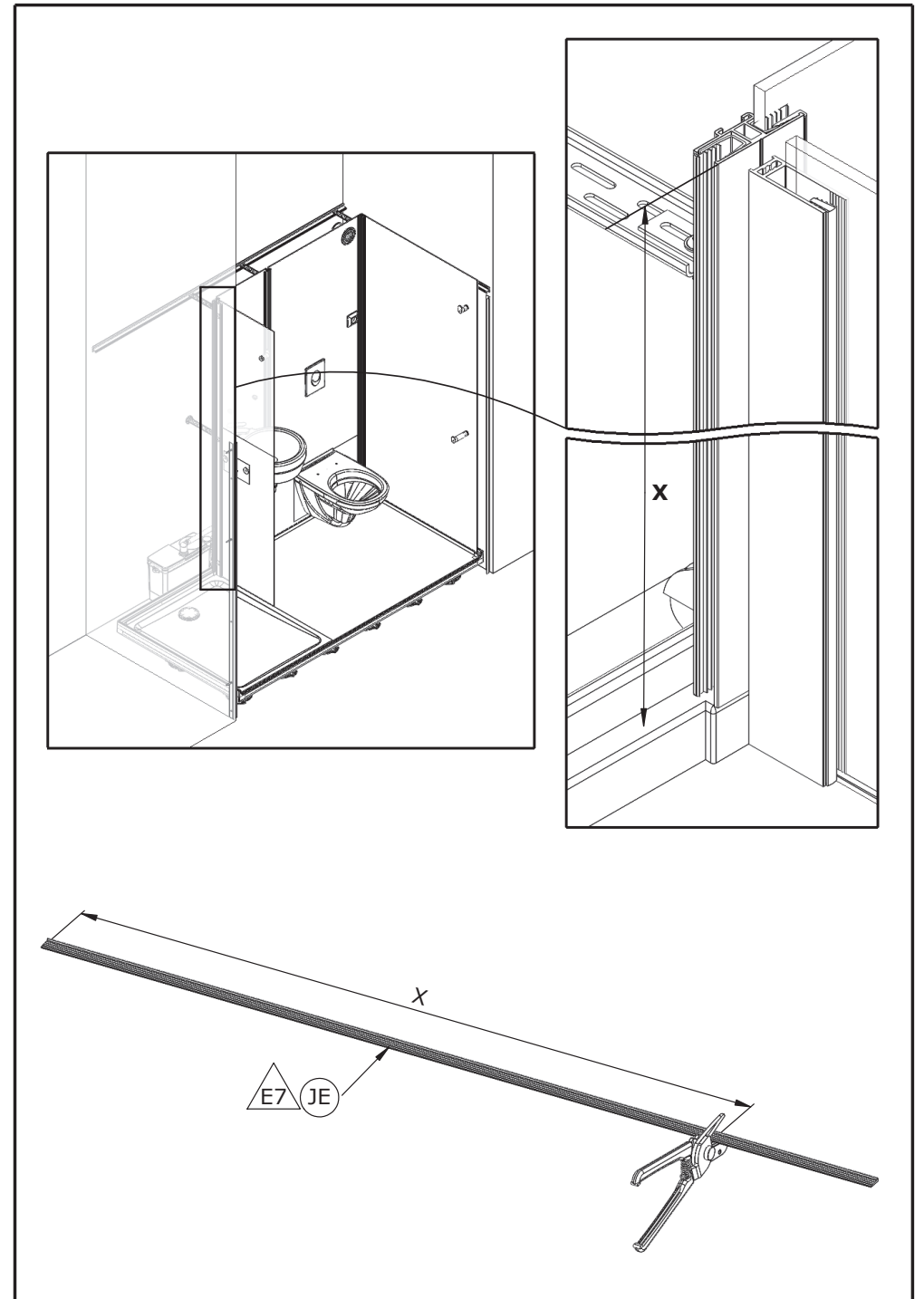
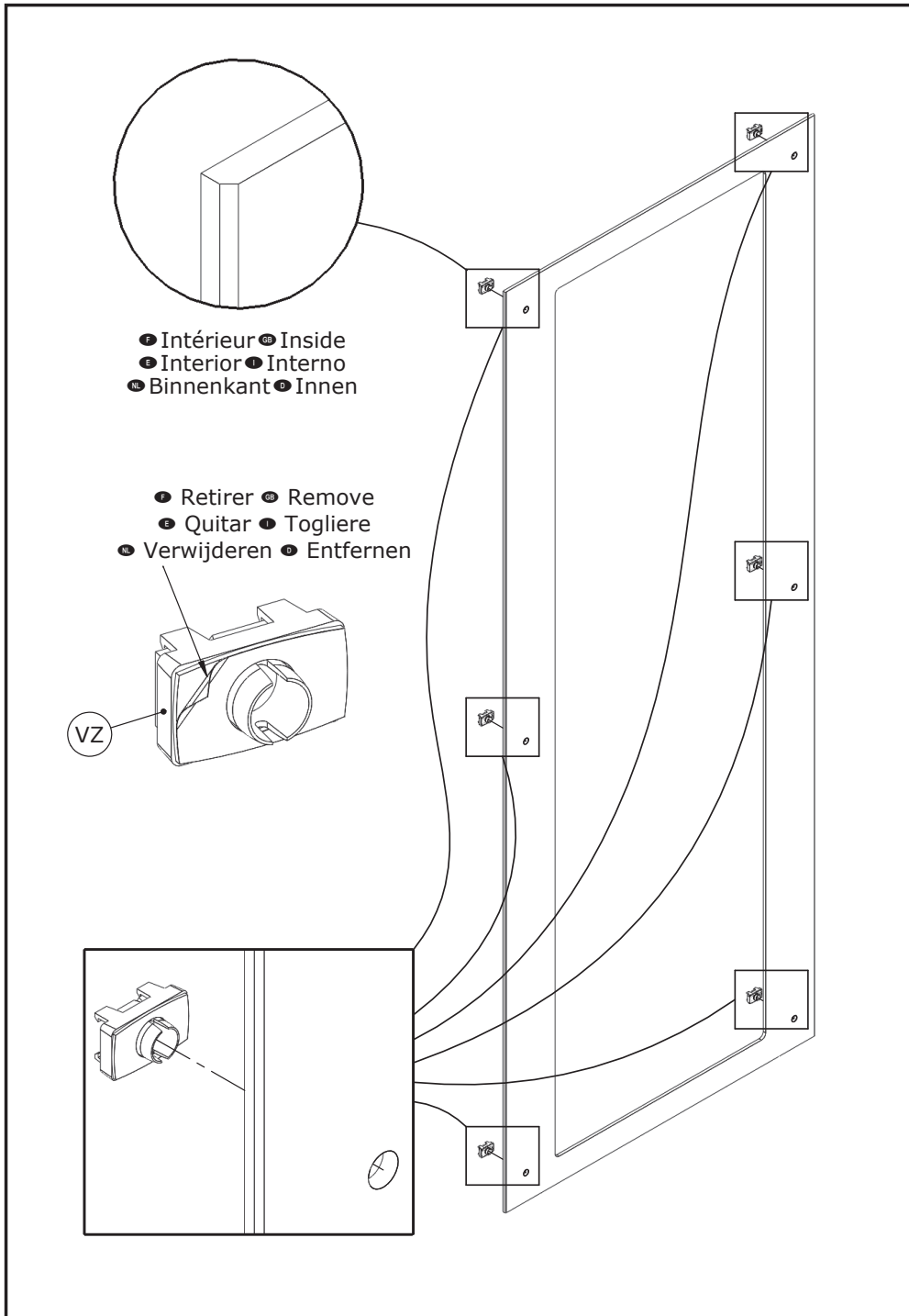

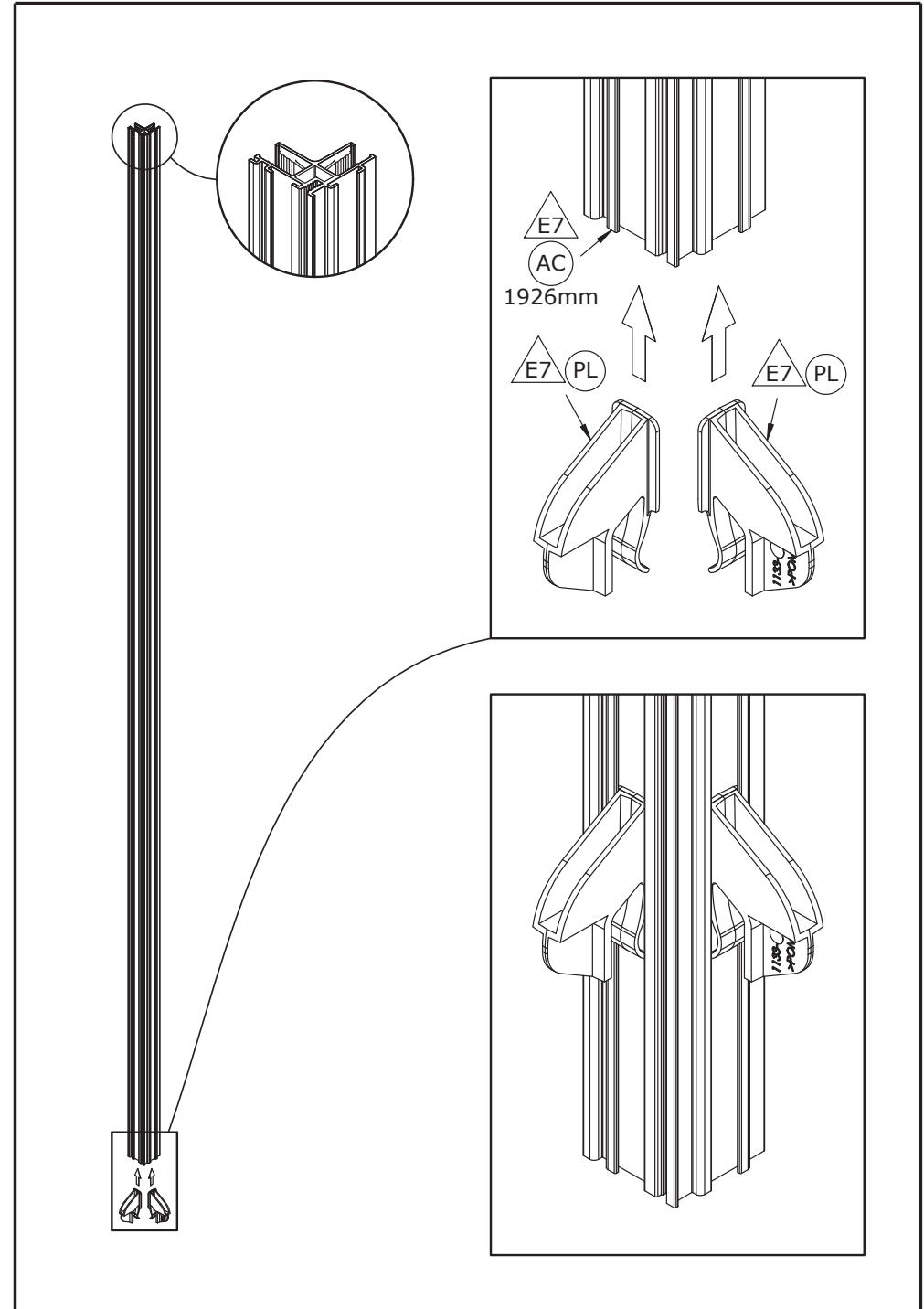
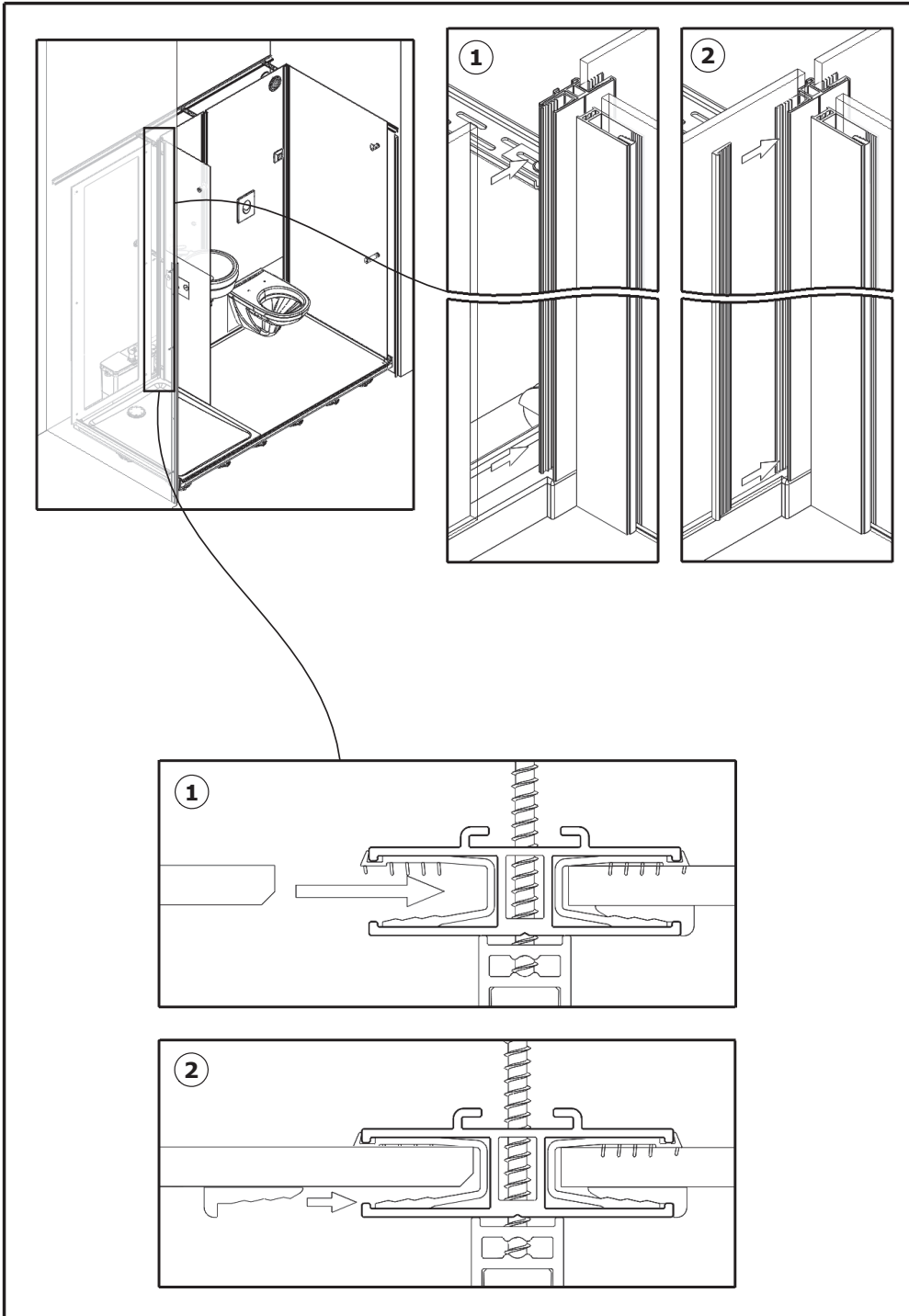

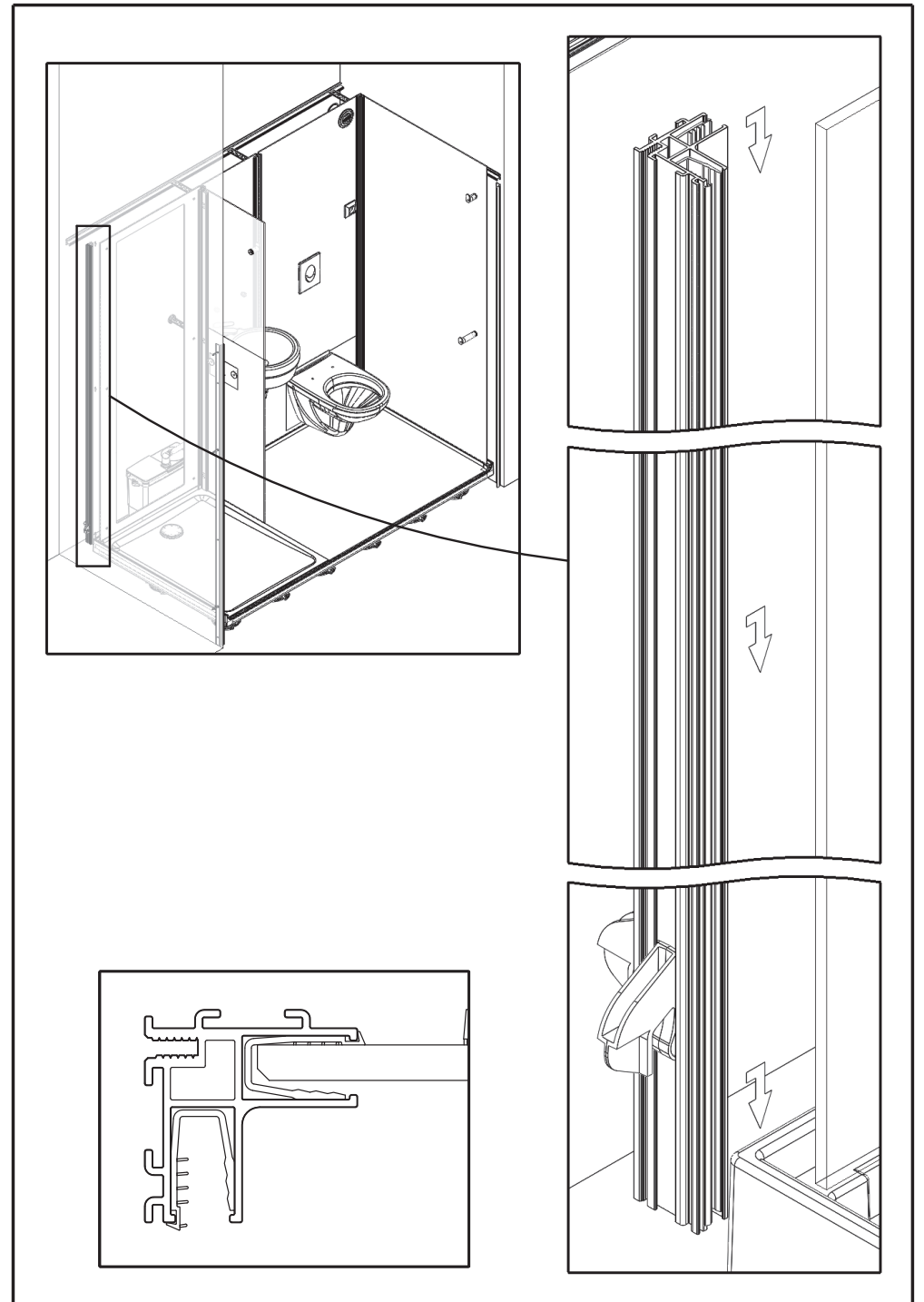
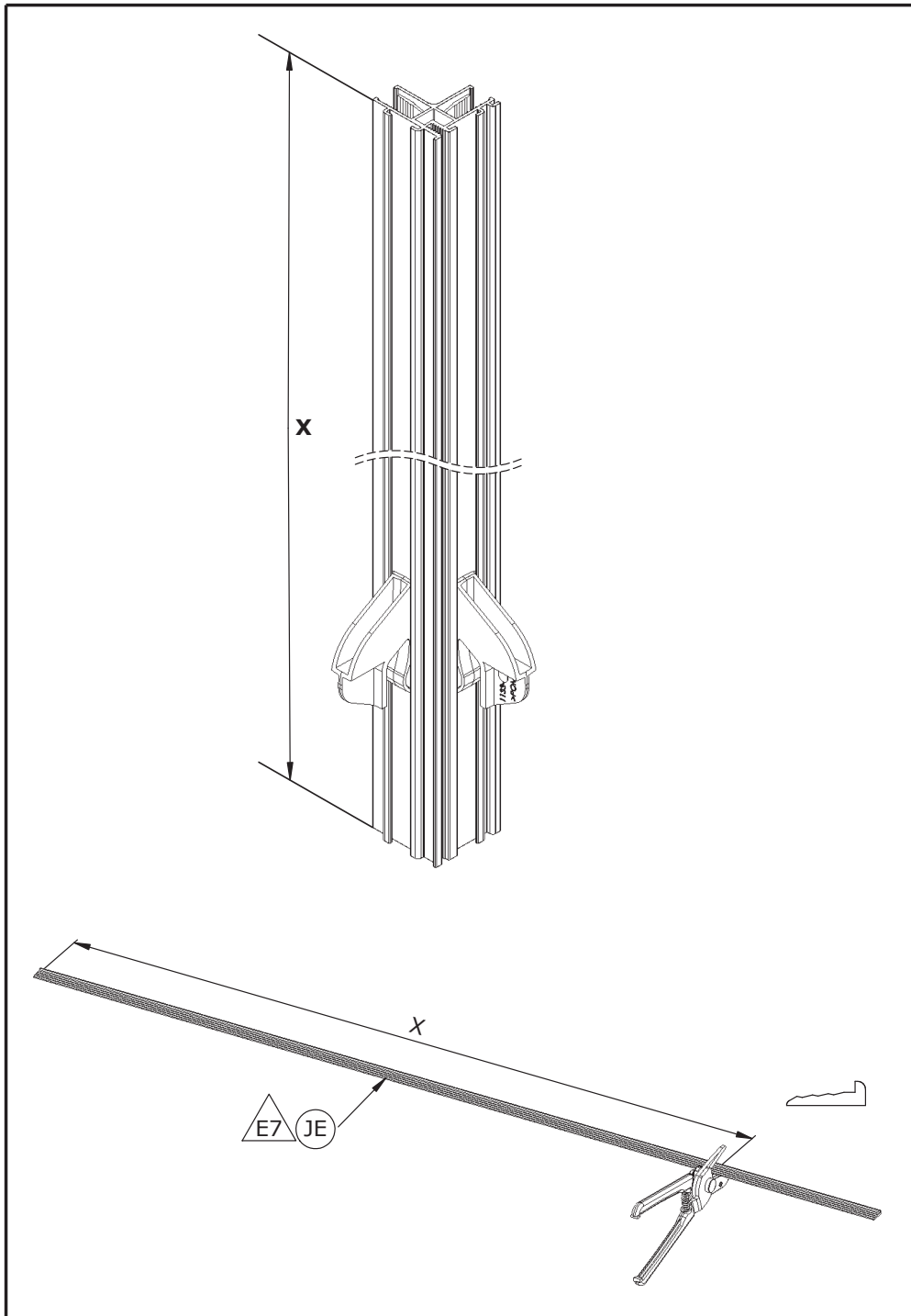

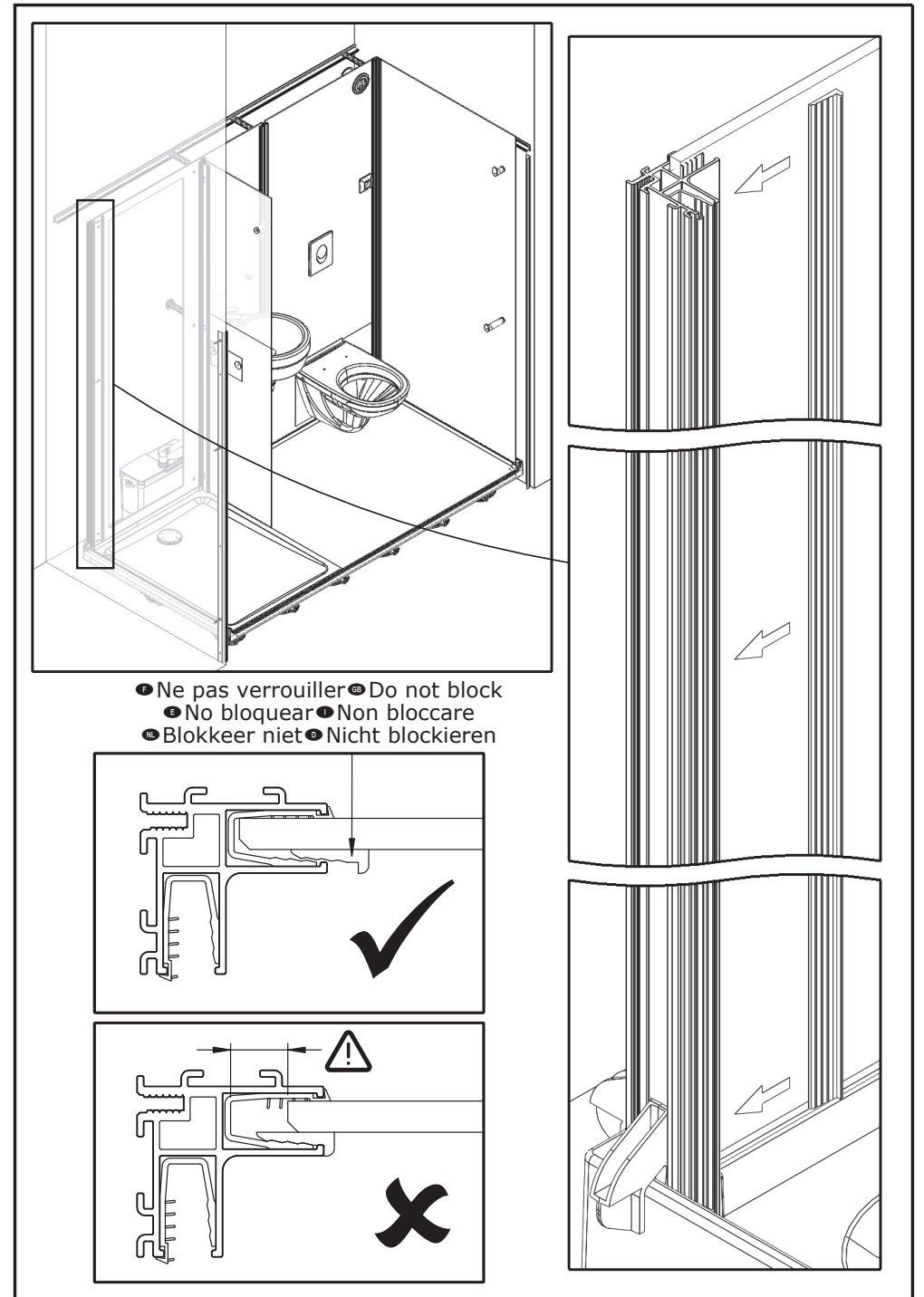
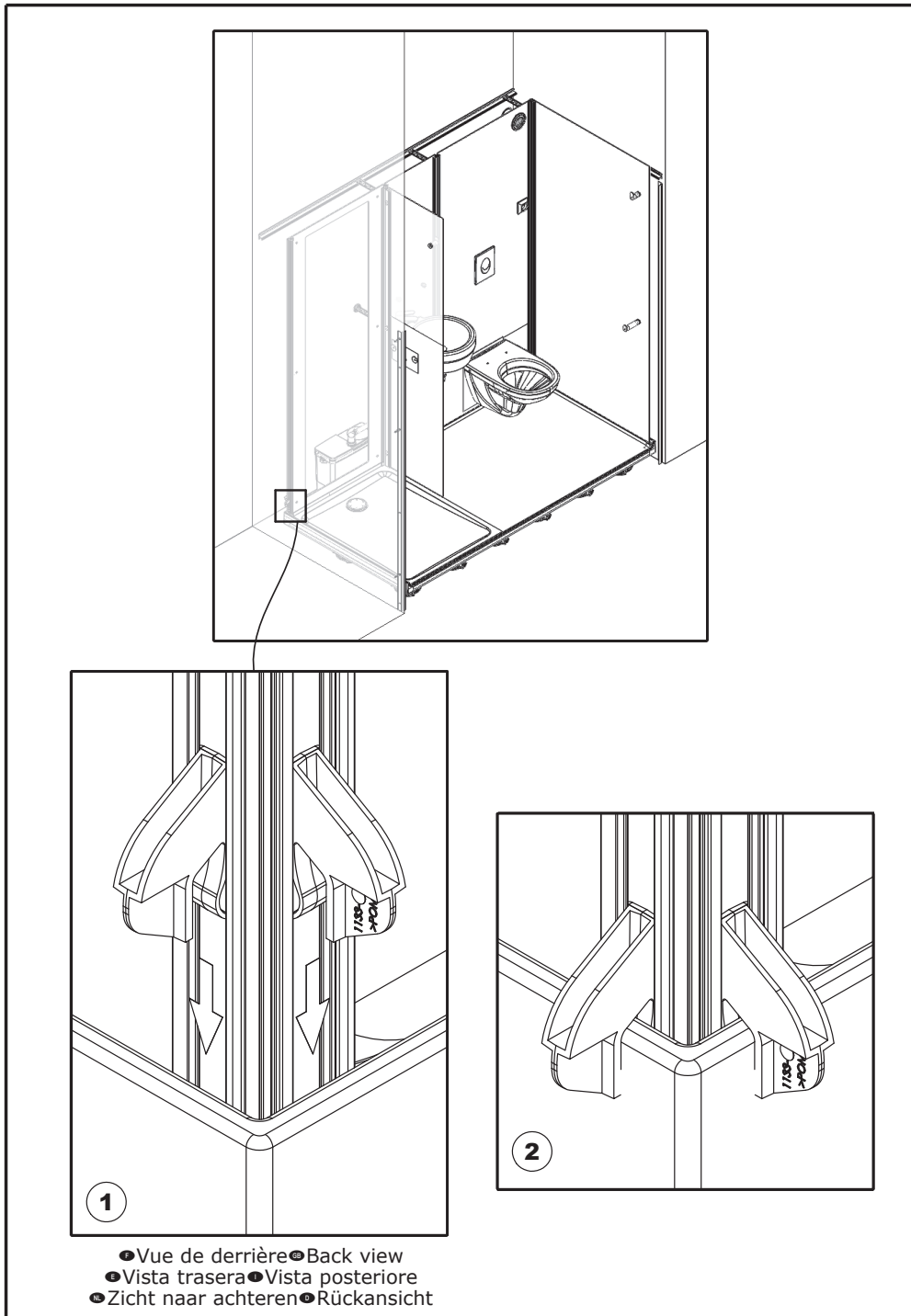

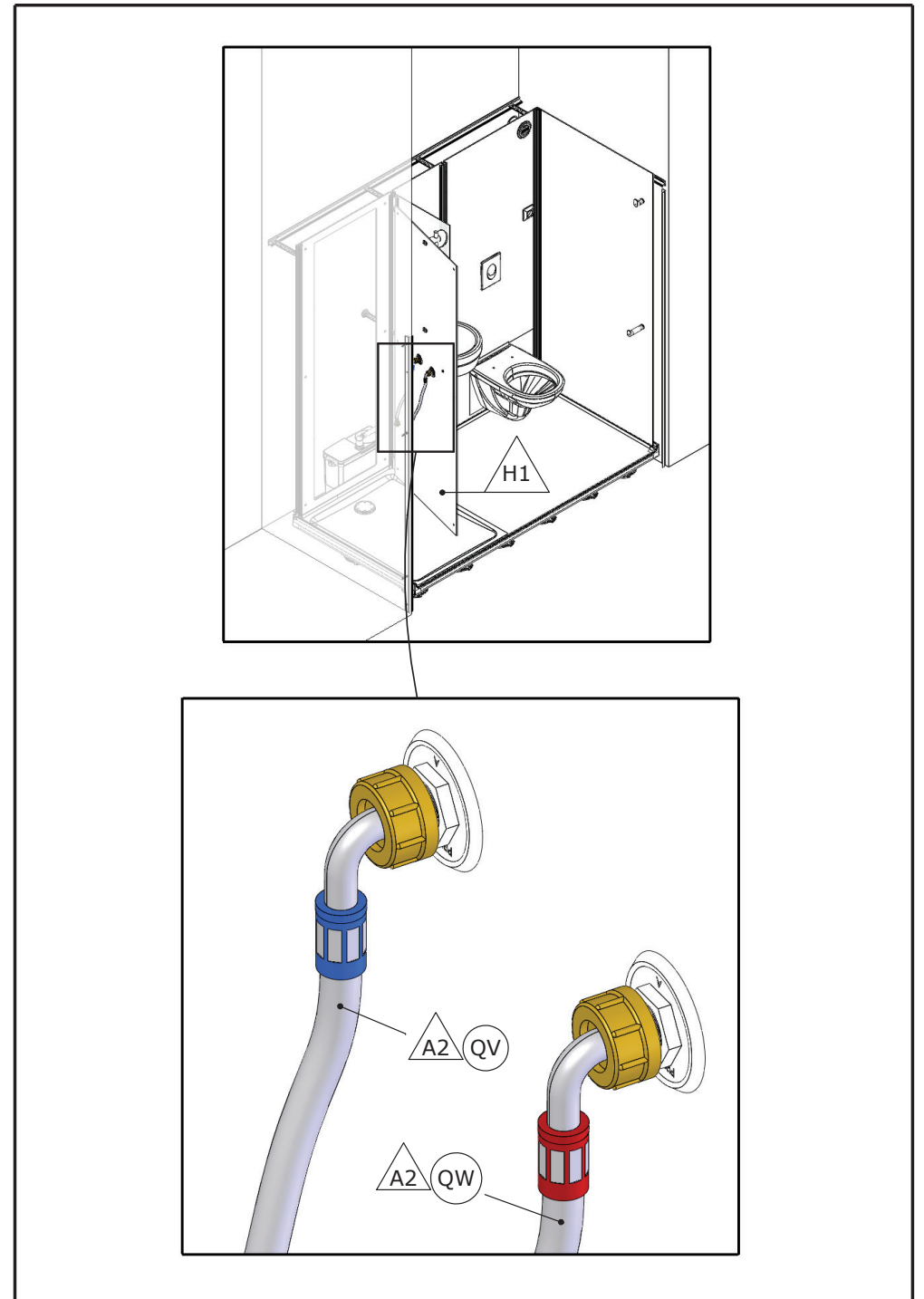
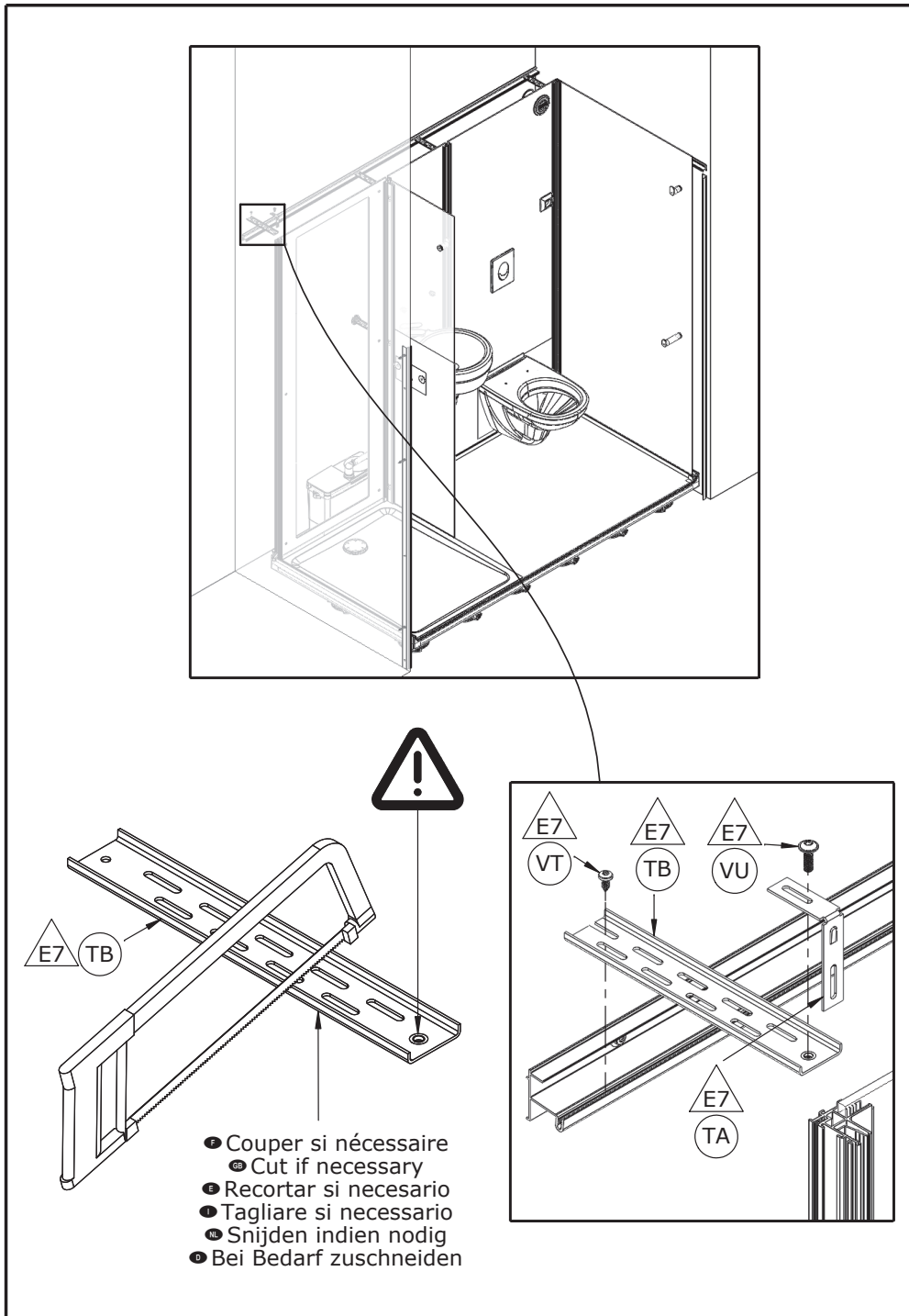

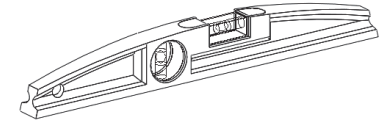
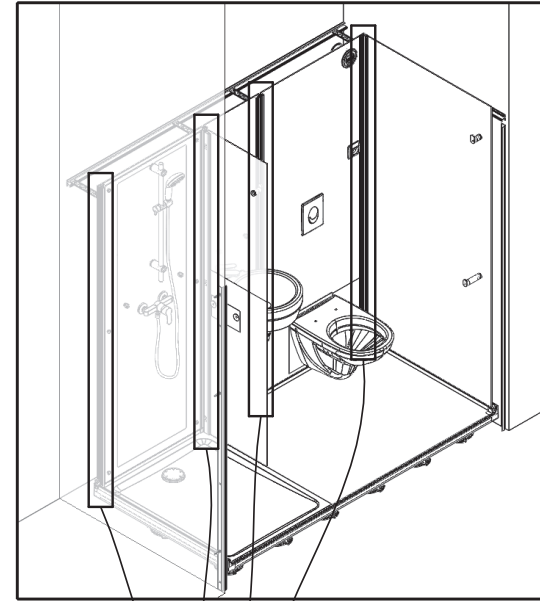
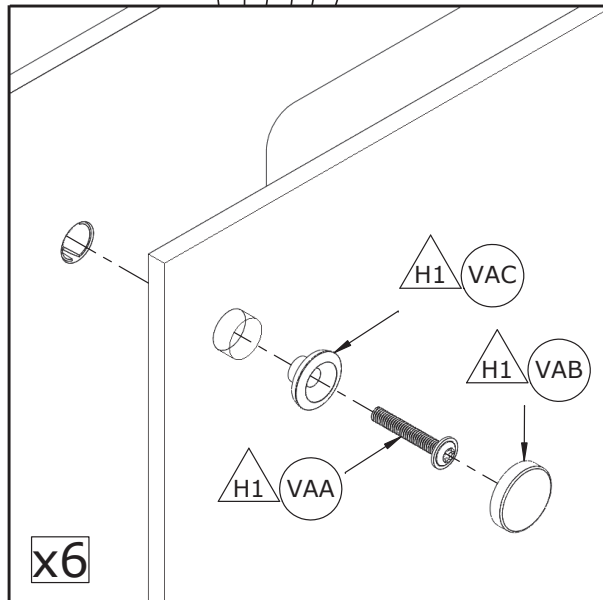
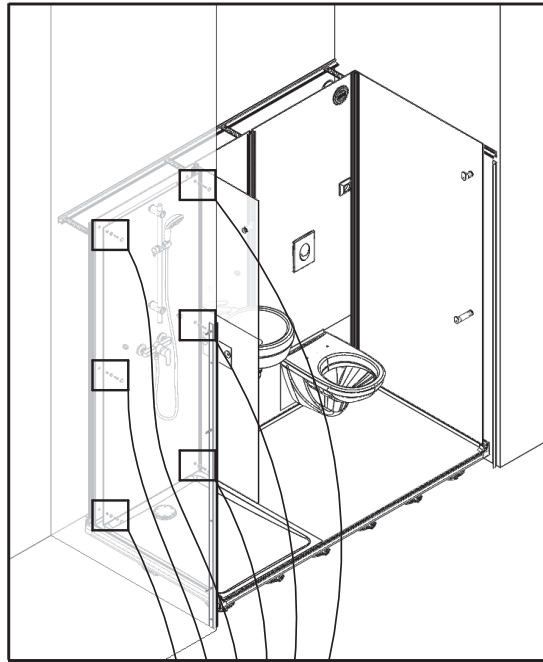

- Vérifier l'aplomb de la cabine, puis verrouiller
- Ensure level then block
- Verificar la verticalidad de la cabina, y bloquear
- Assicurarsi che la doccia è di livello, e bloccare
- Controleer of de douchecabine goed recht staat, en blokkeer
- Prüfen, ob die Kabine lotrecht steht, anschließend blockieren

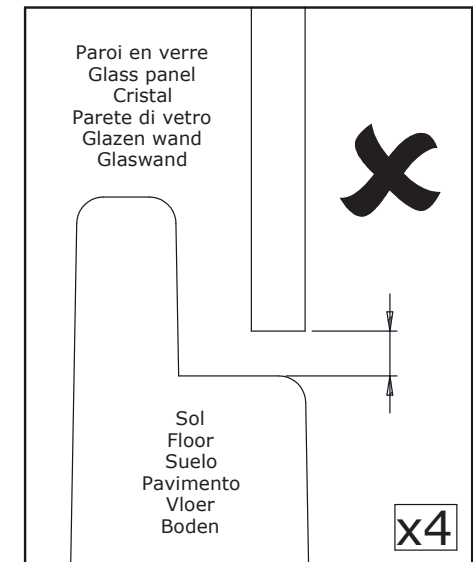
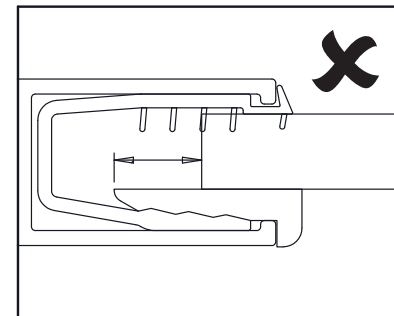
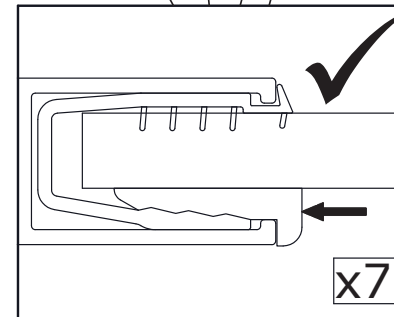

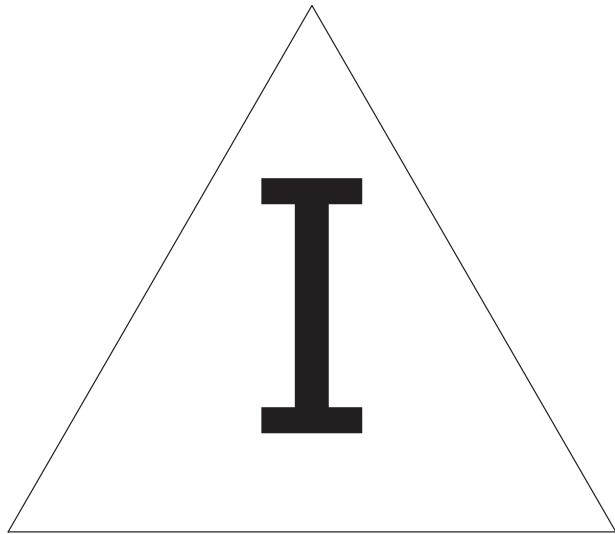

The diagram is enclosed in a rectangular border and is divided into two main sections. The top section shows a perspective view of a lighting fixture being inserted into a track. A small component labeled 'PP' is shown being pushed into the fixture. The track is labeled with a triangle containing 'I', a circle containing 'AQ', and the length '903mm'. The bottom section shows a side view of the fixture with a warning triangle (a triangle with an exclamation mark) above it. Below the side view is a list of mounting directions in multiple languages.

- Sens de montage
- Ⓢ Mounting direction
- Ⓔ Dirección de montaje
- Senso di montaggio
- Ⓜ Montagerichtung
- Montagerichtung

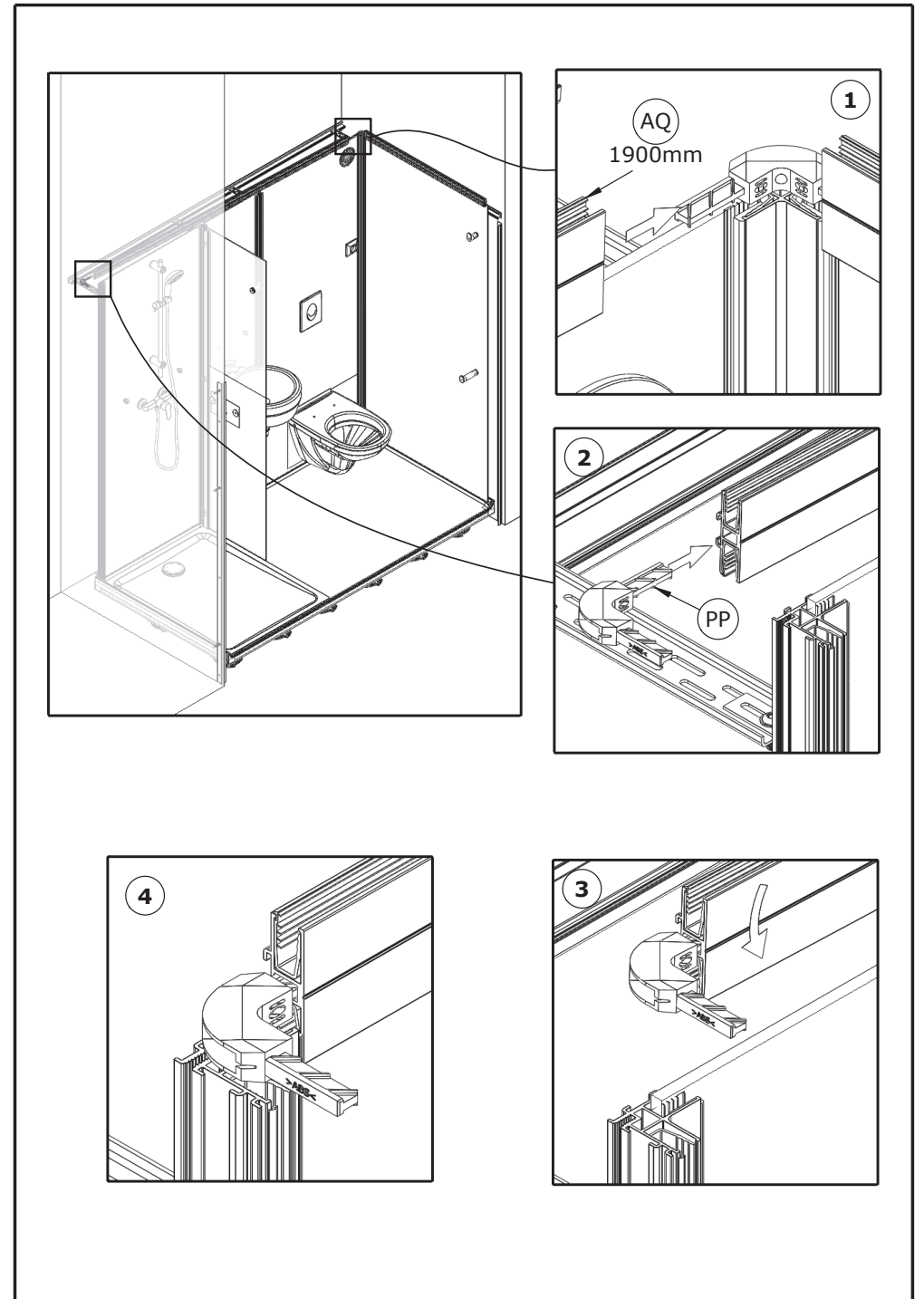
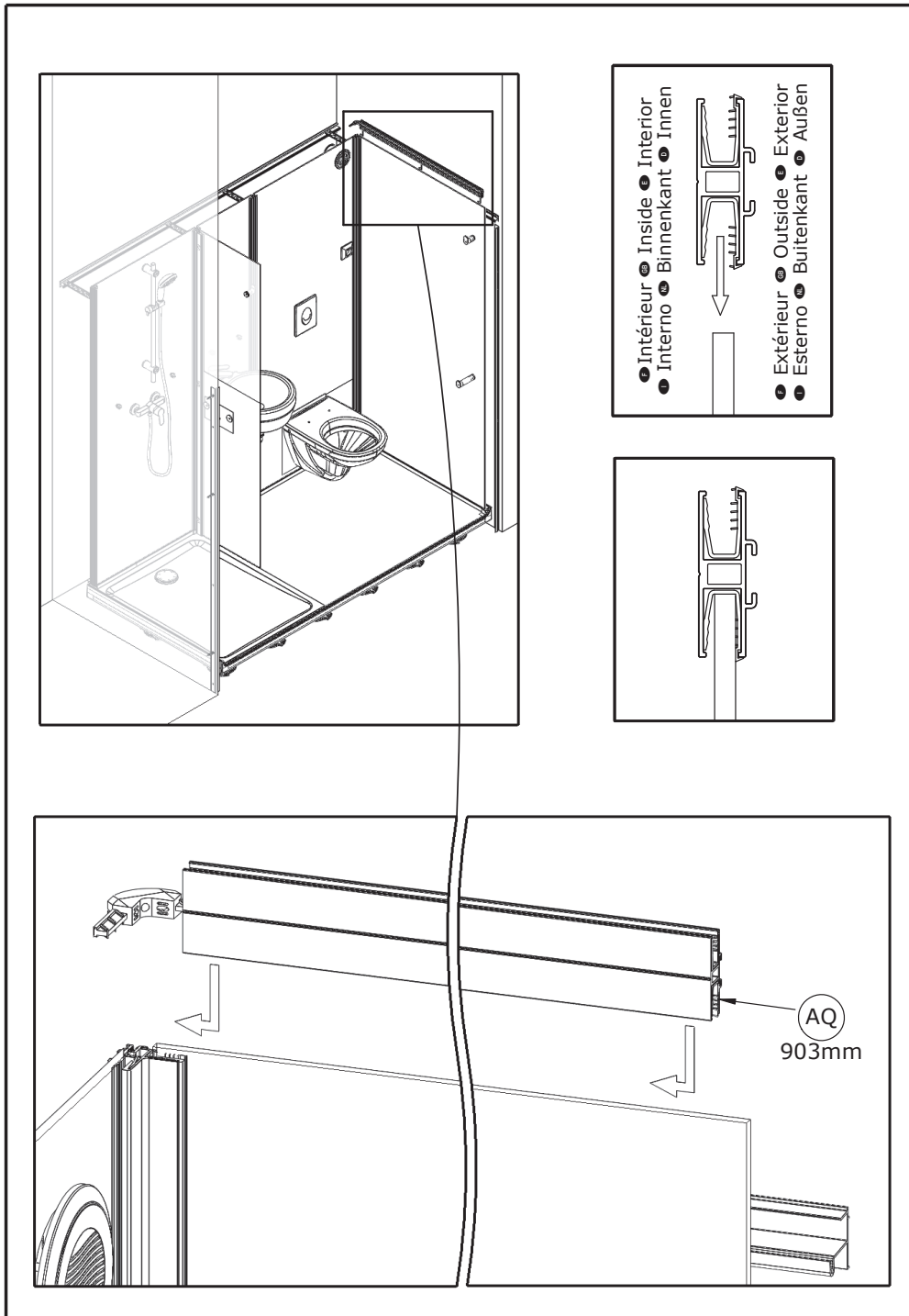

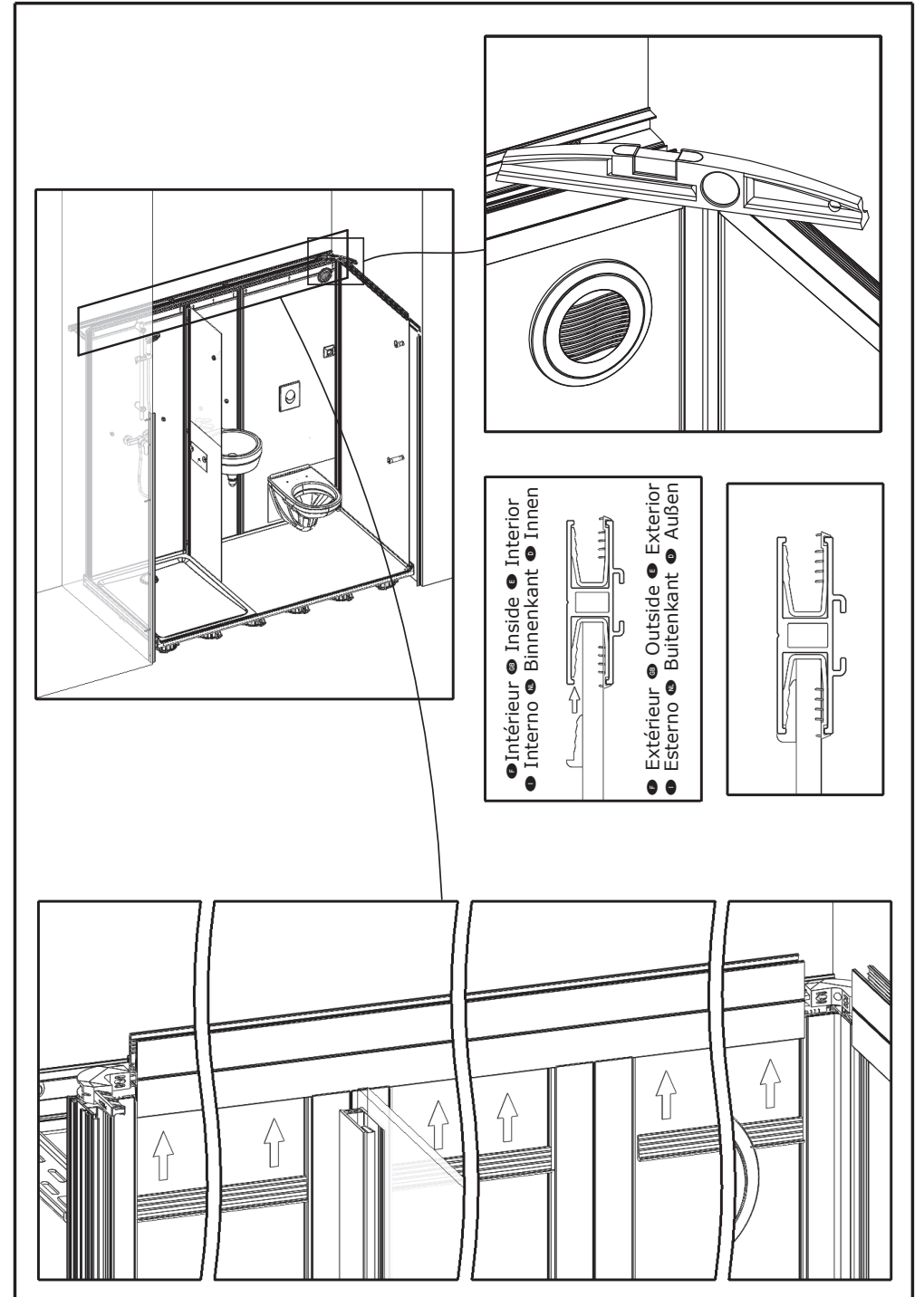
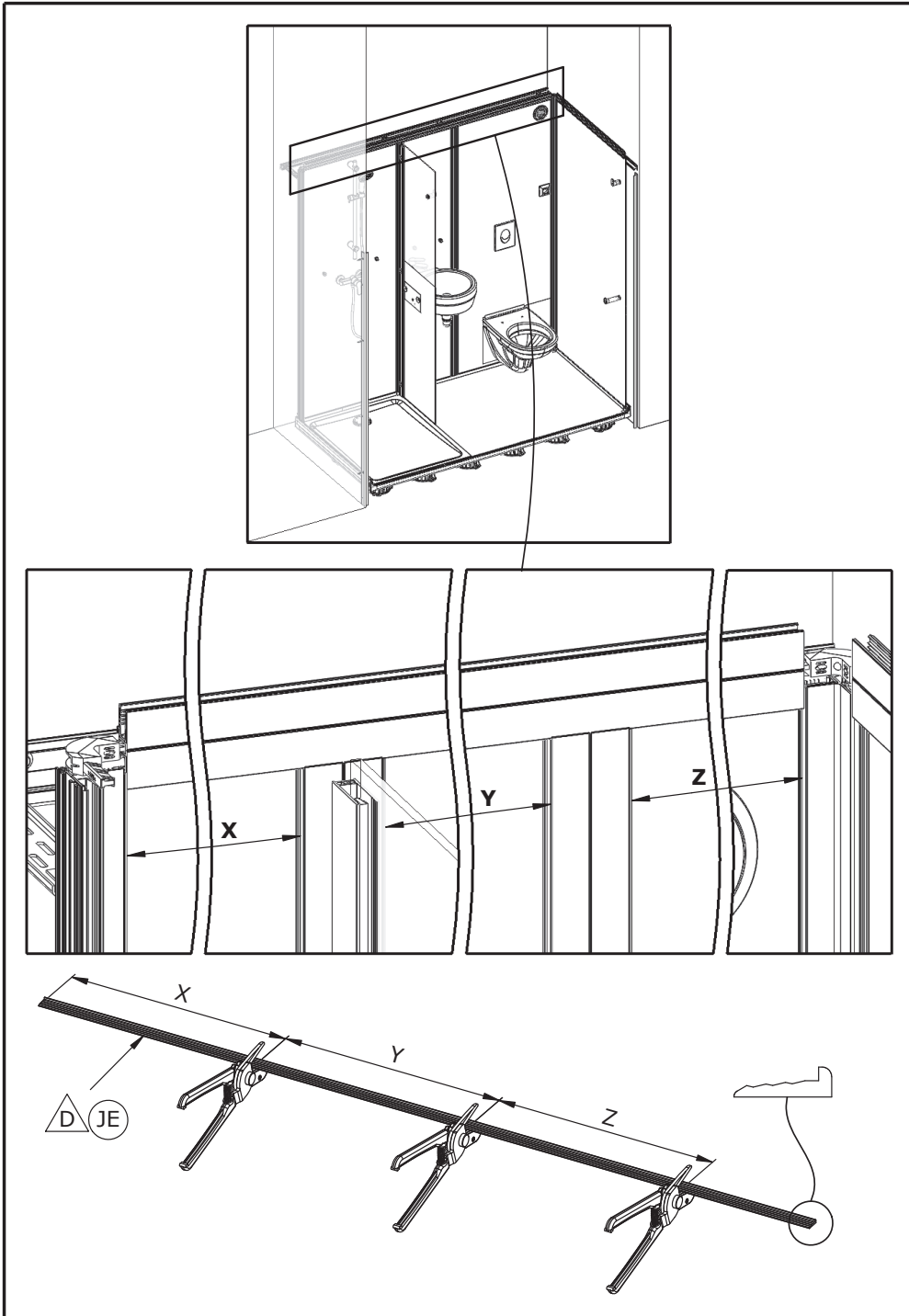

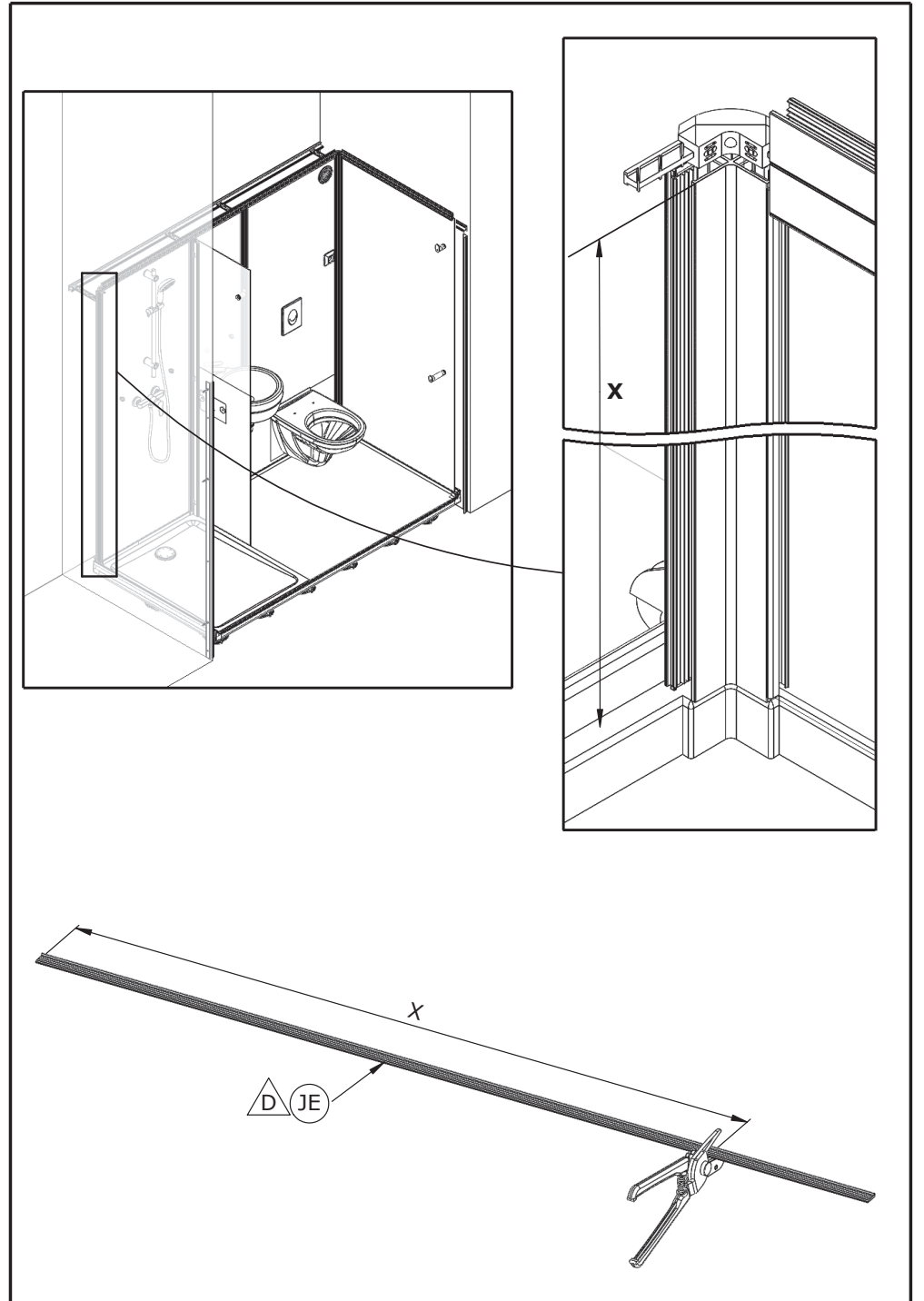
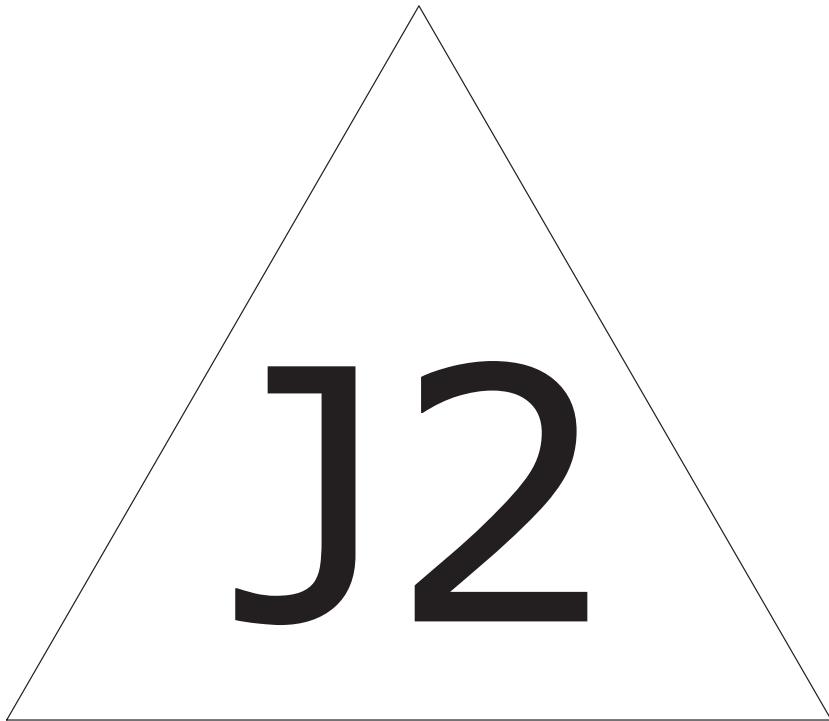

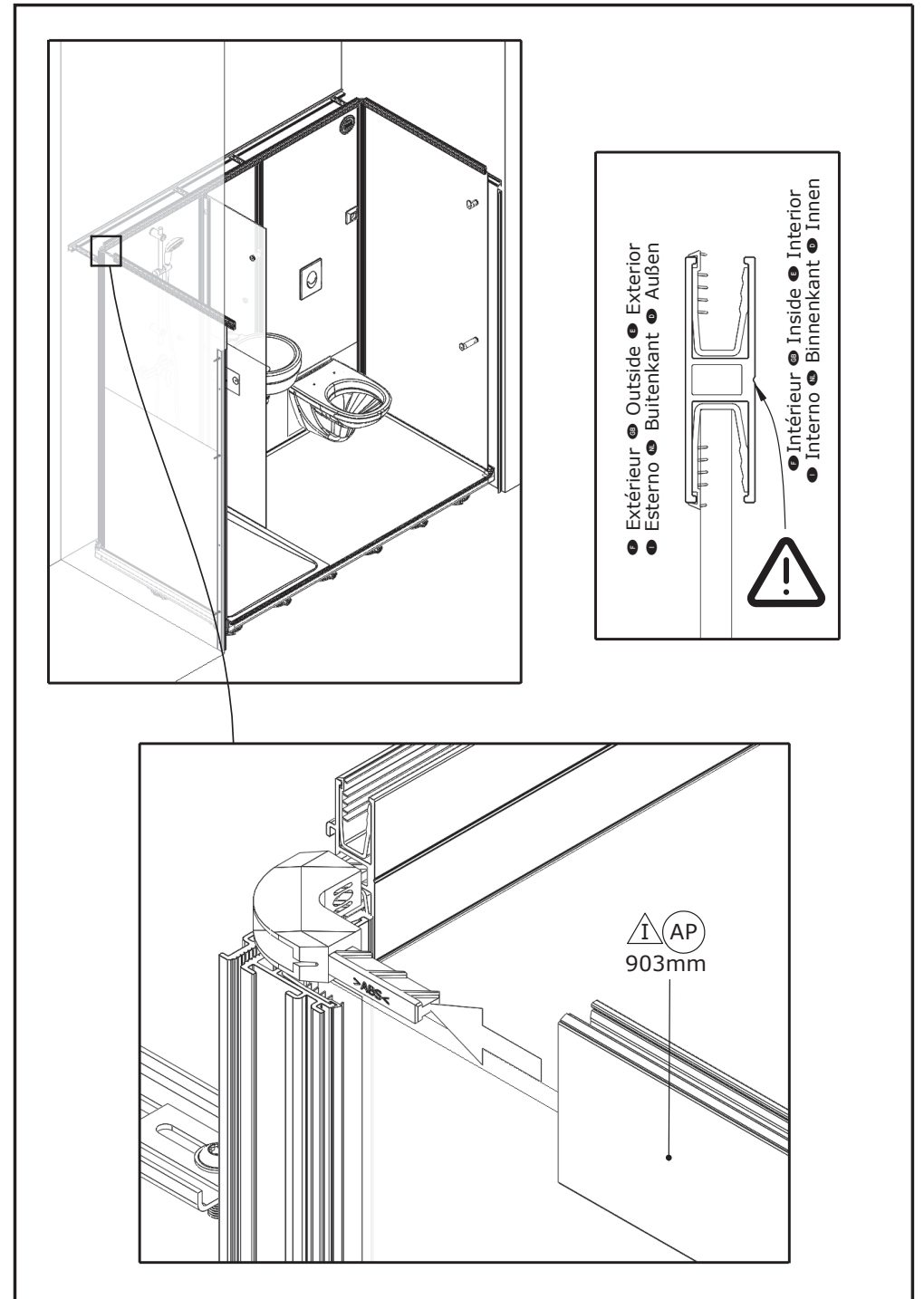
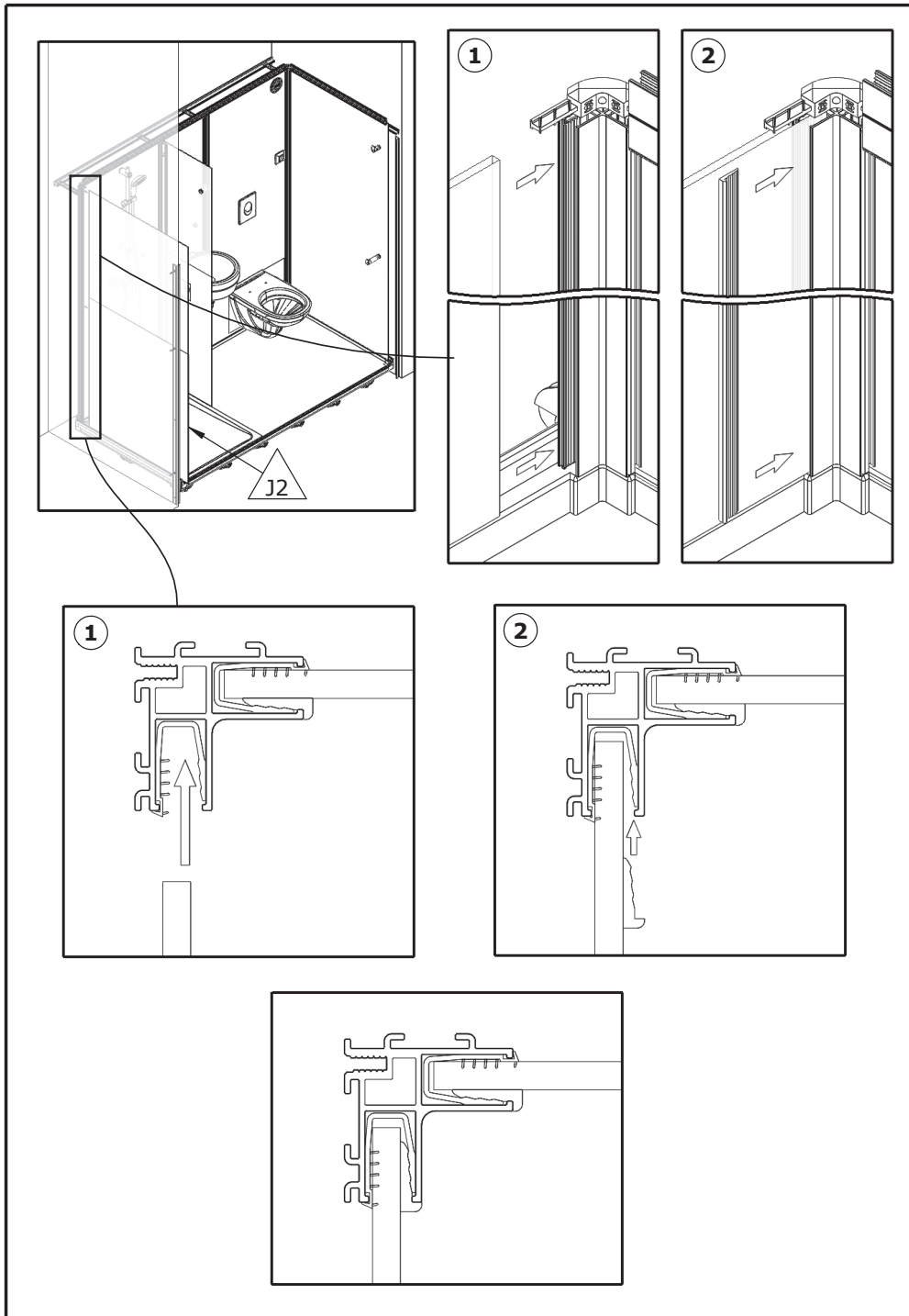

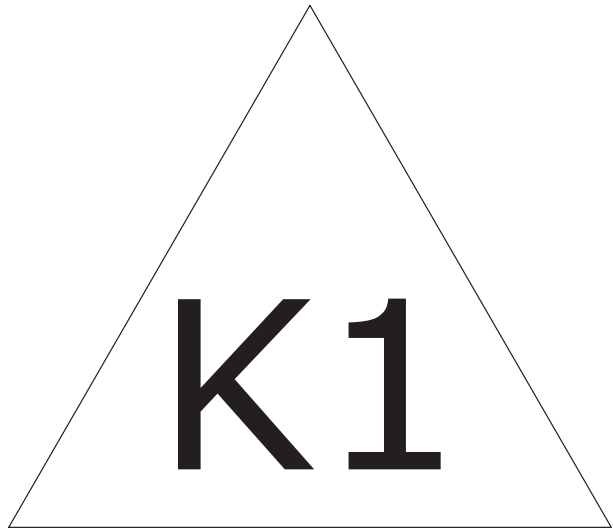

+

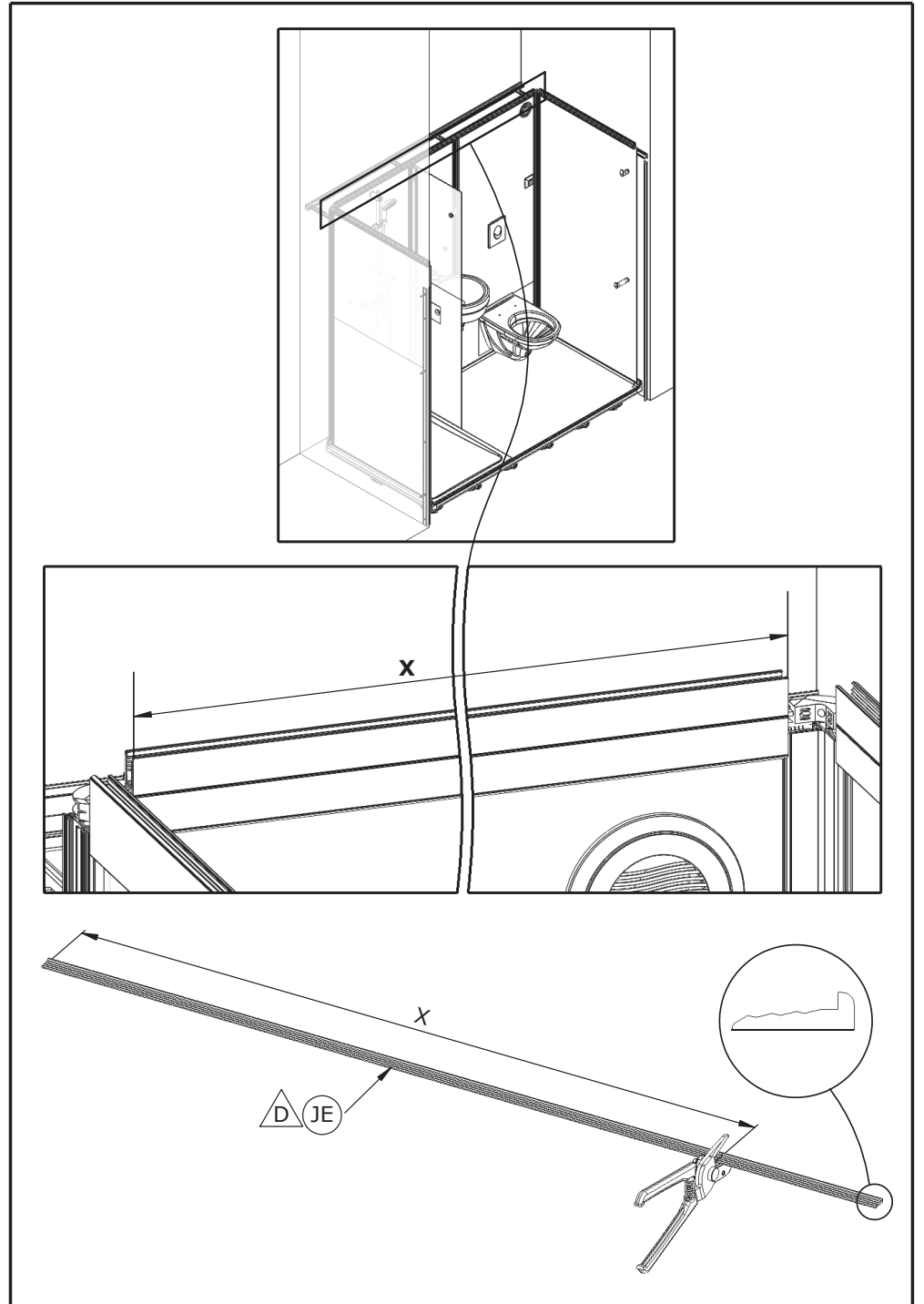
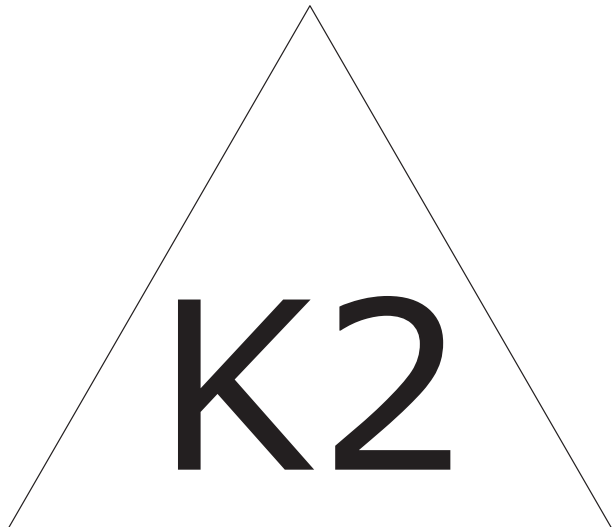

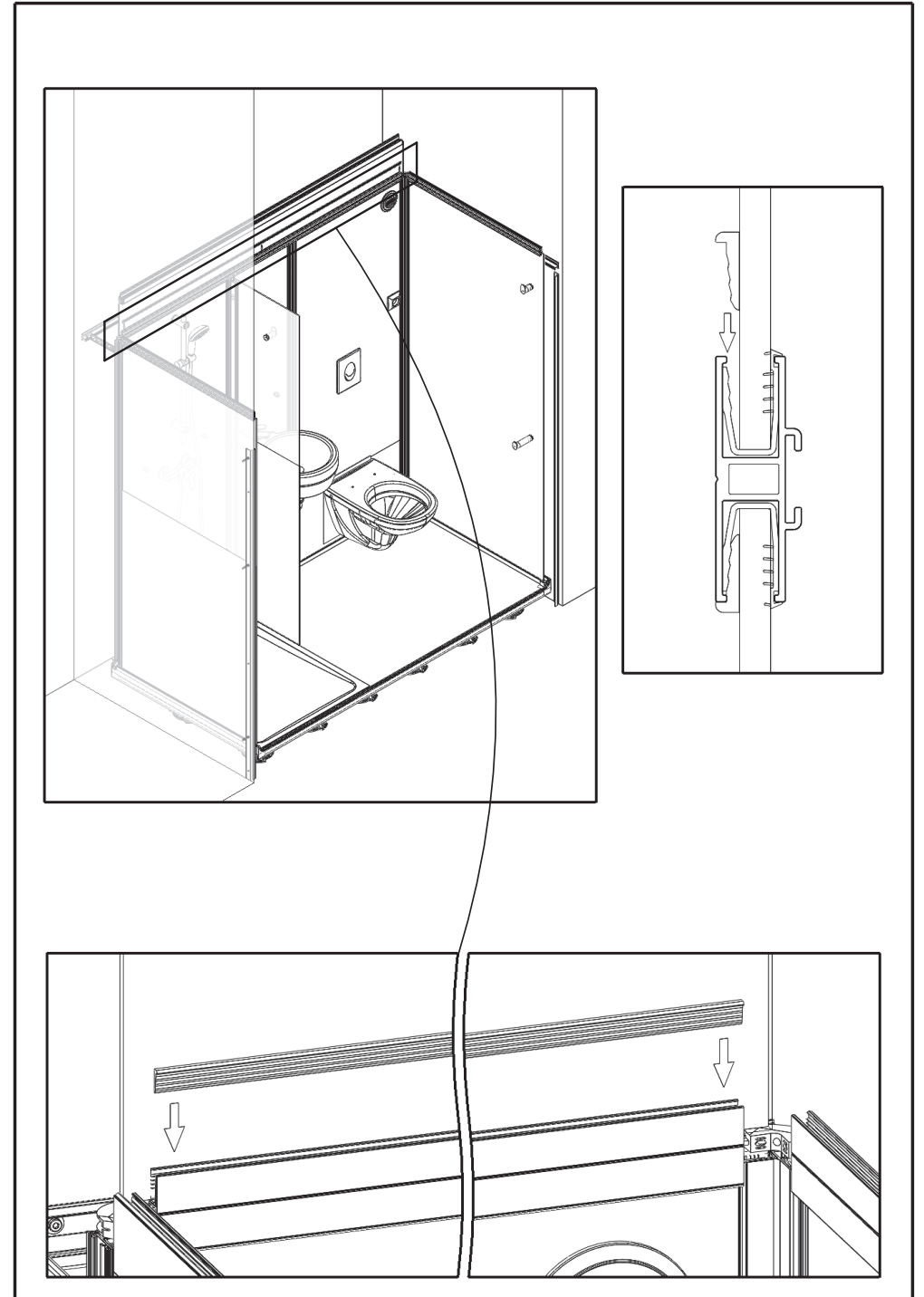
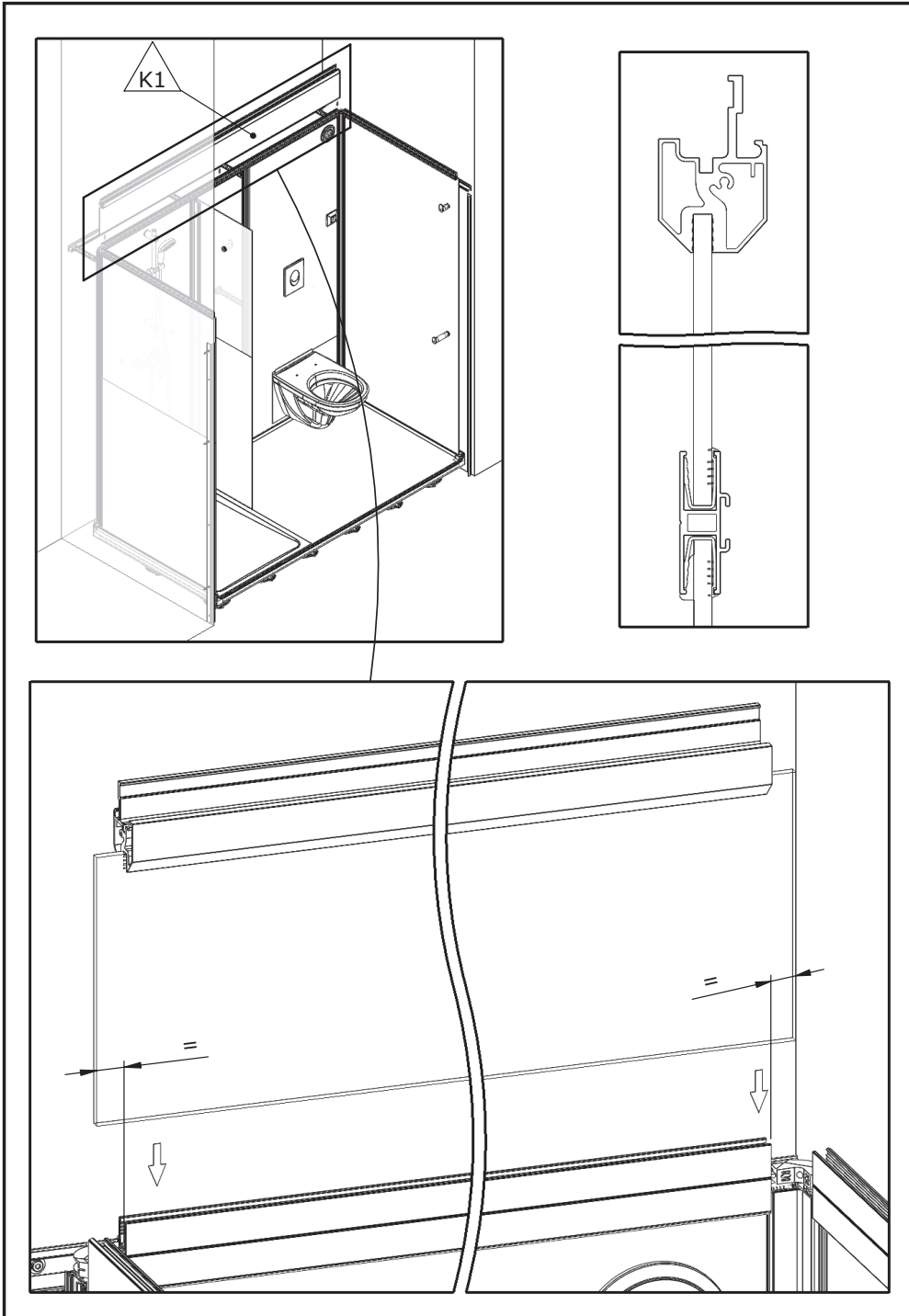

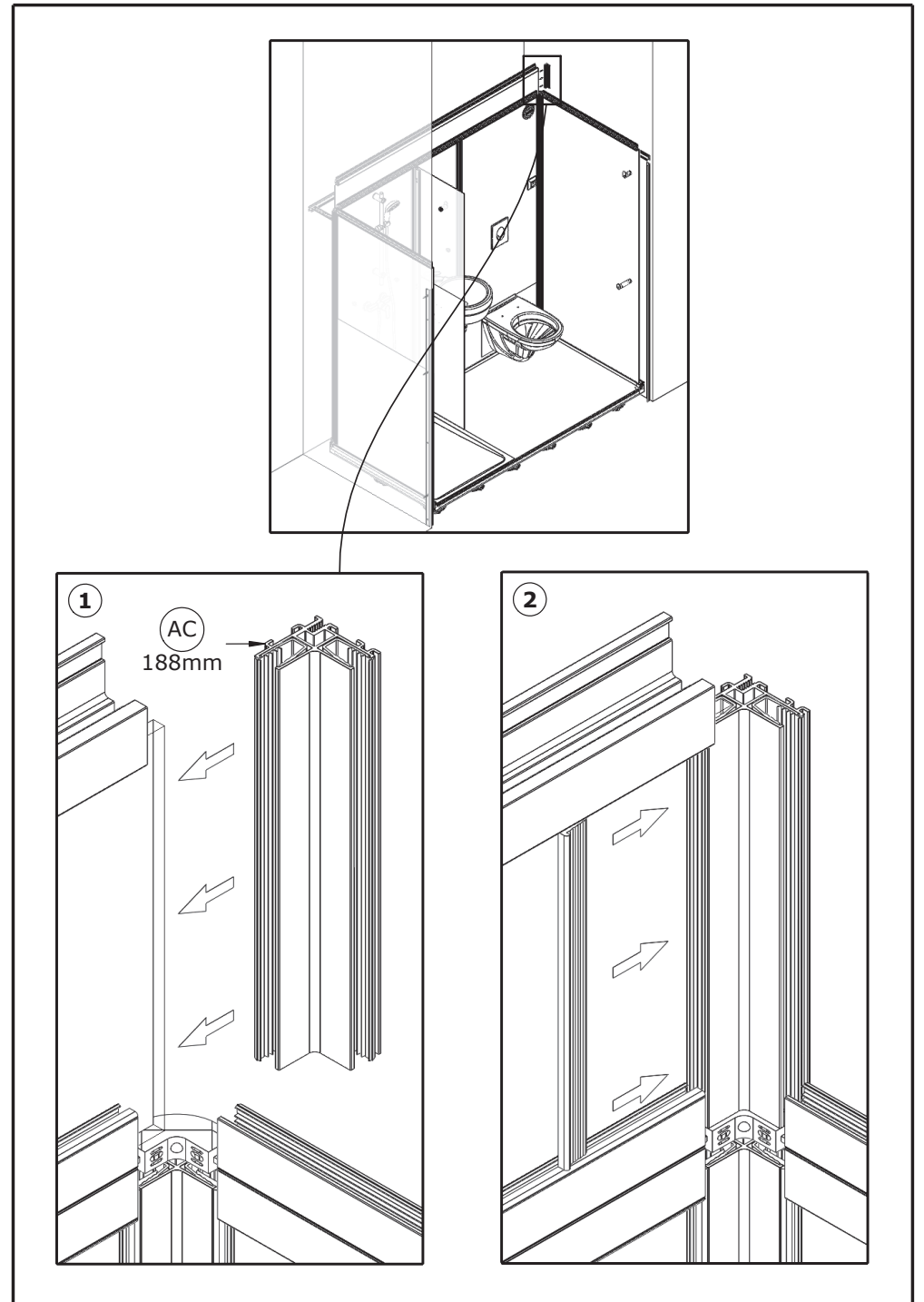
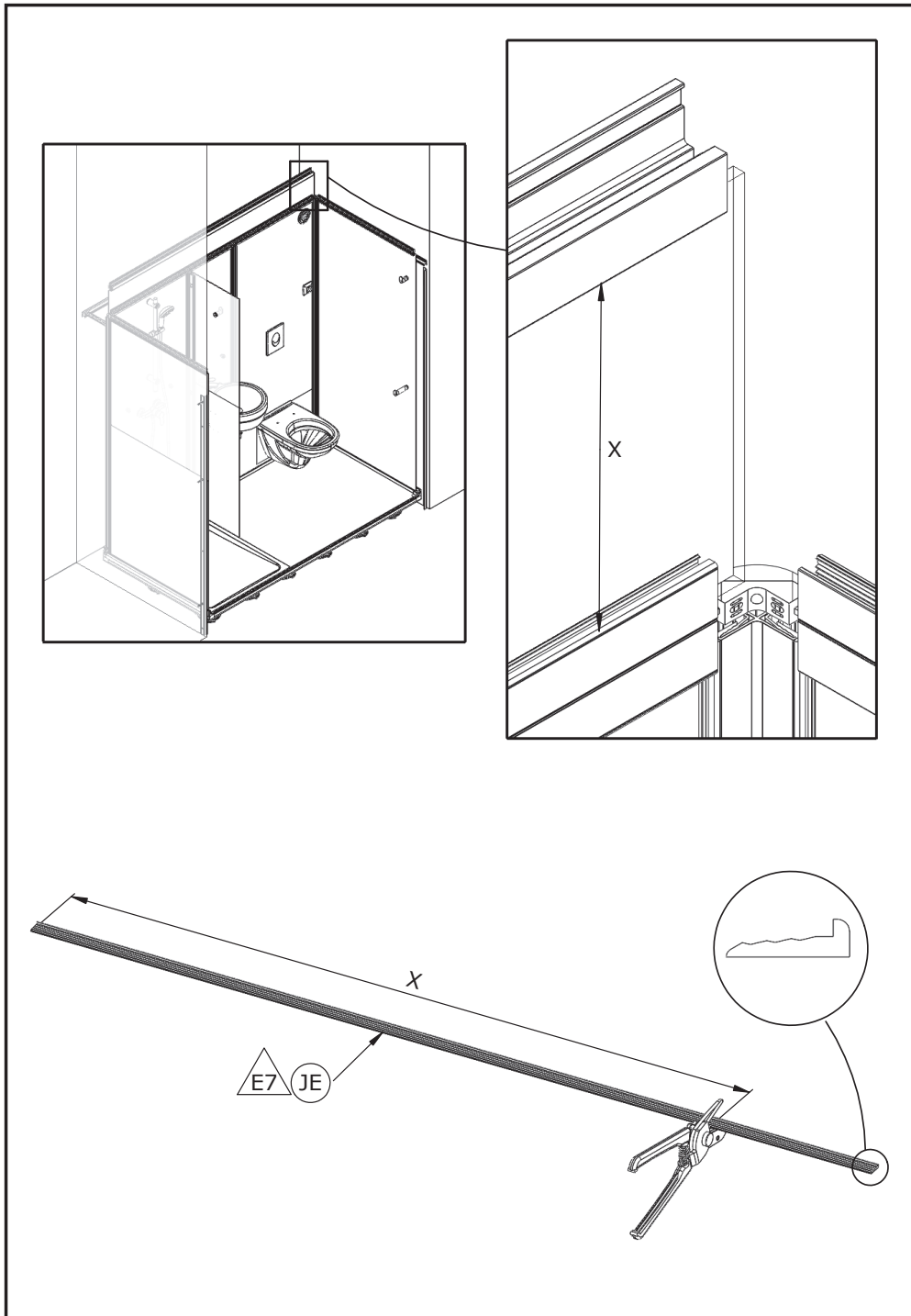

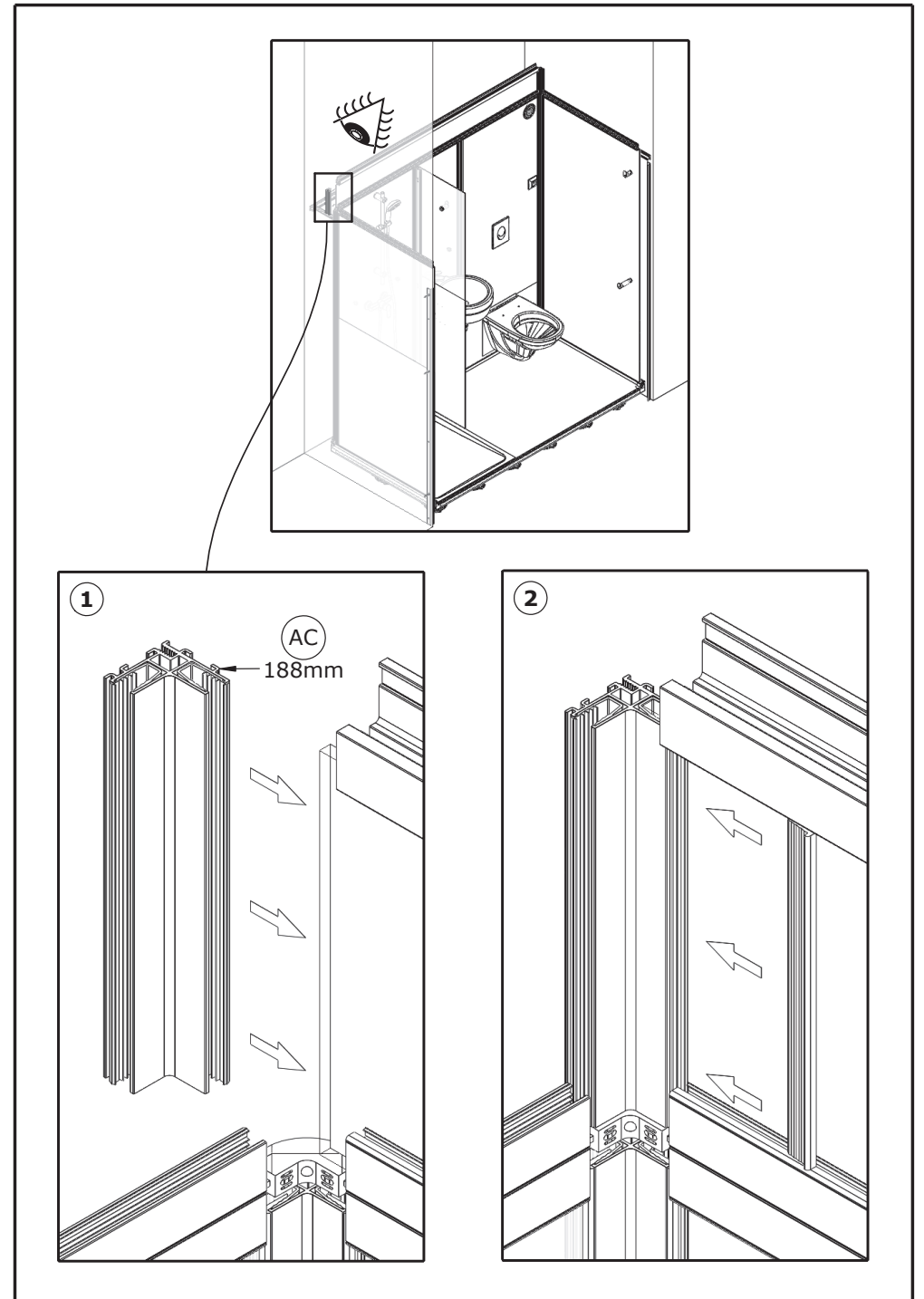
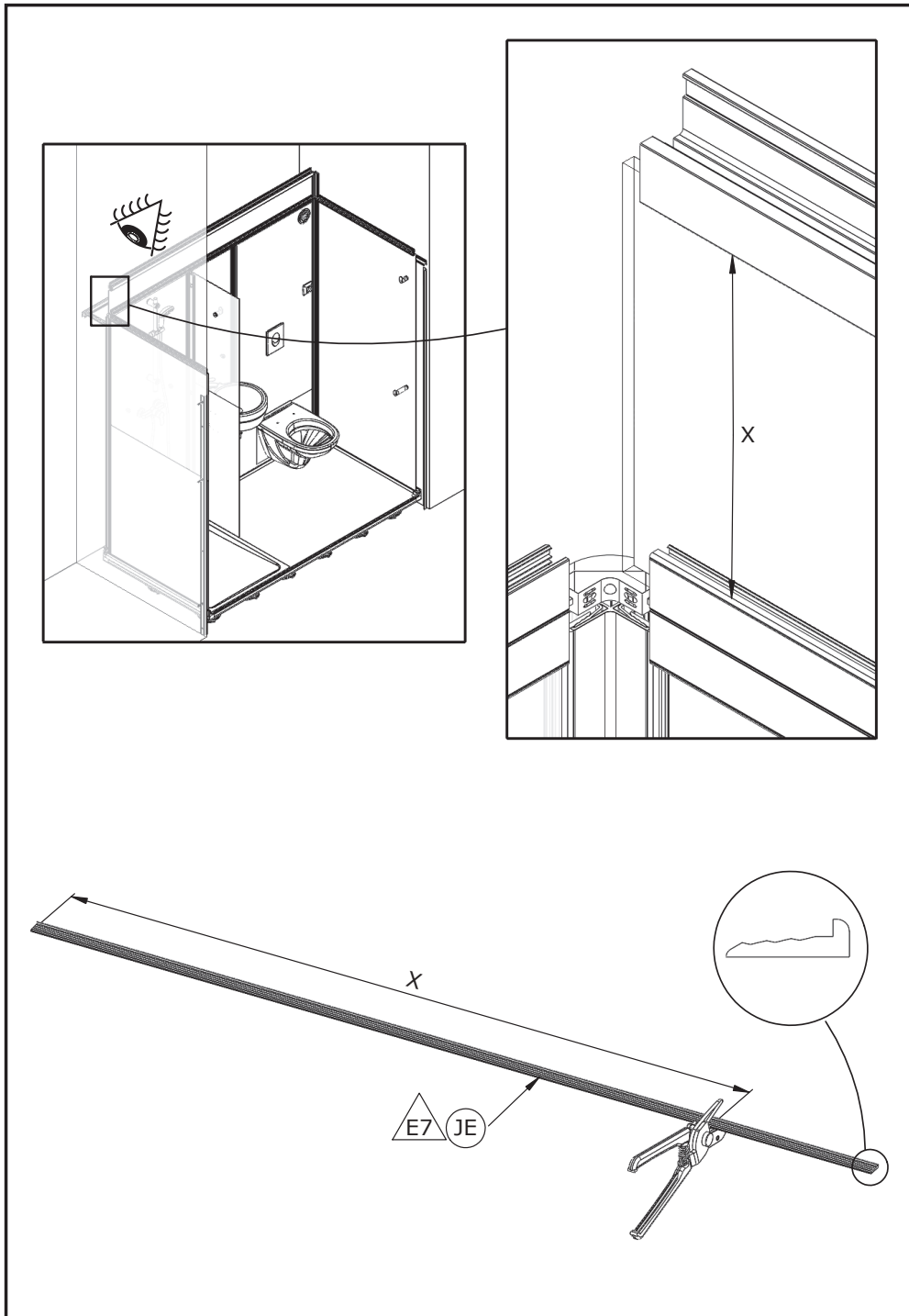

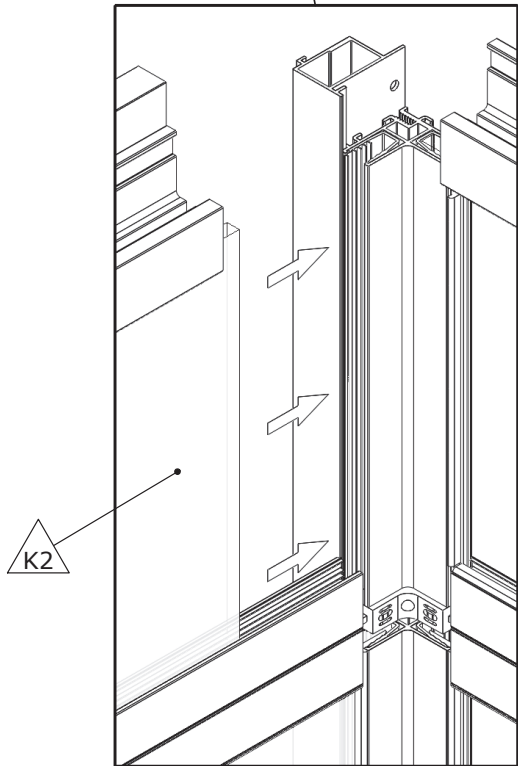
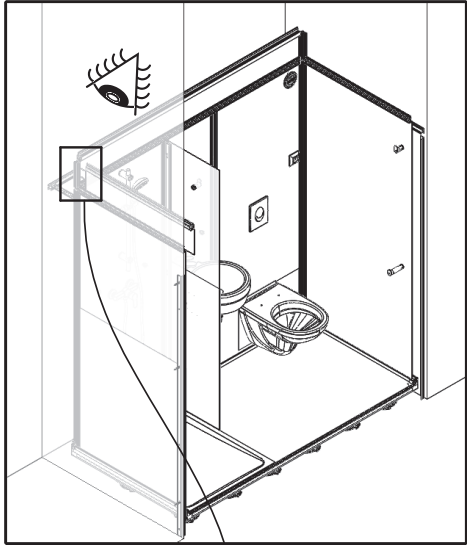

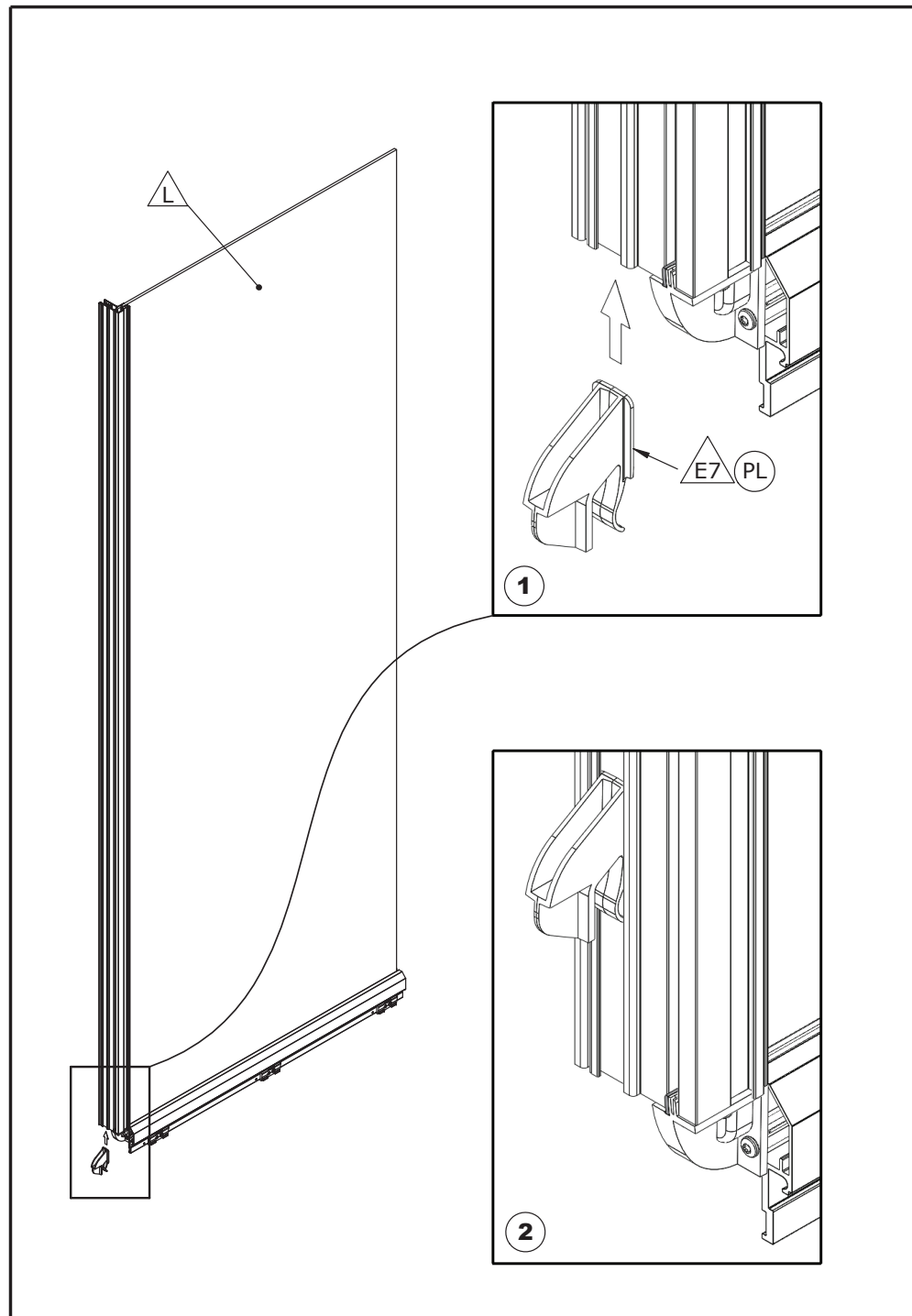
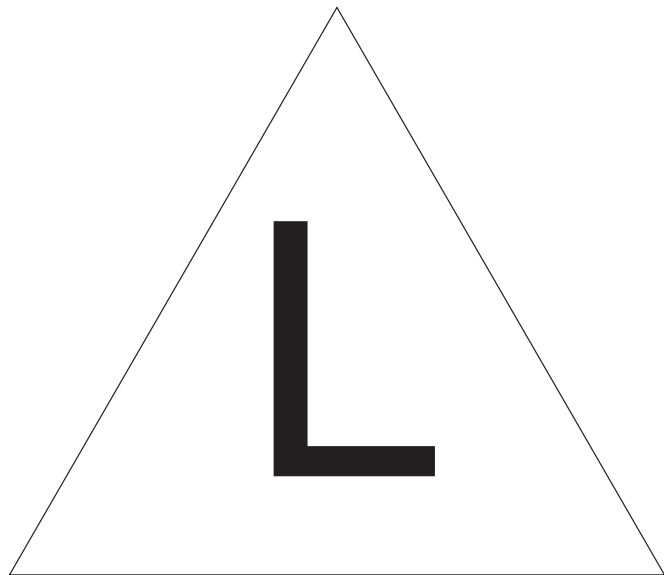

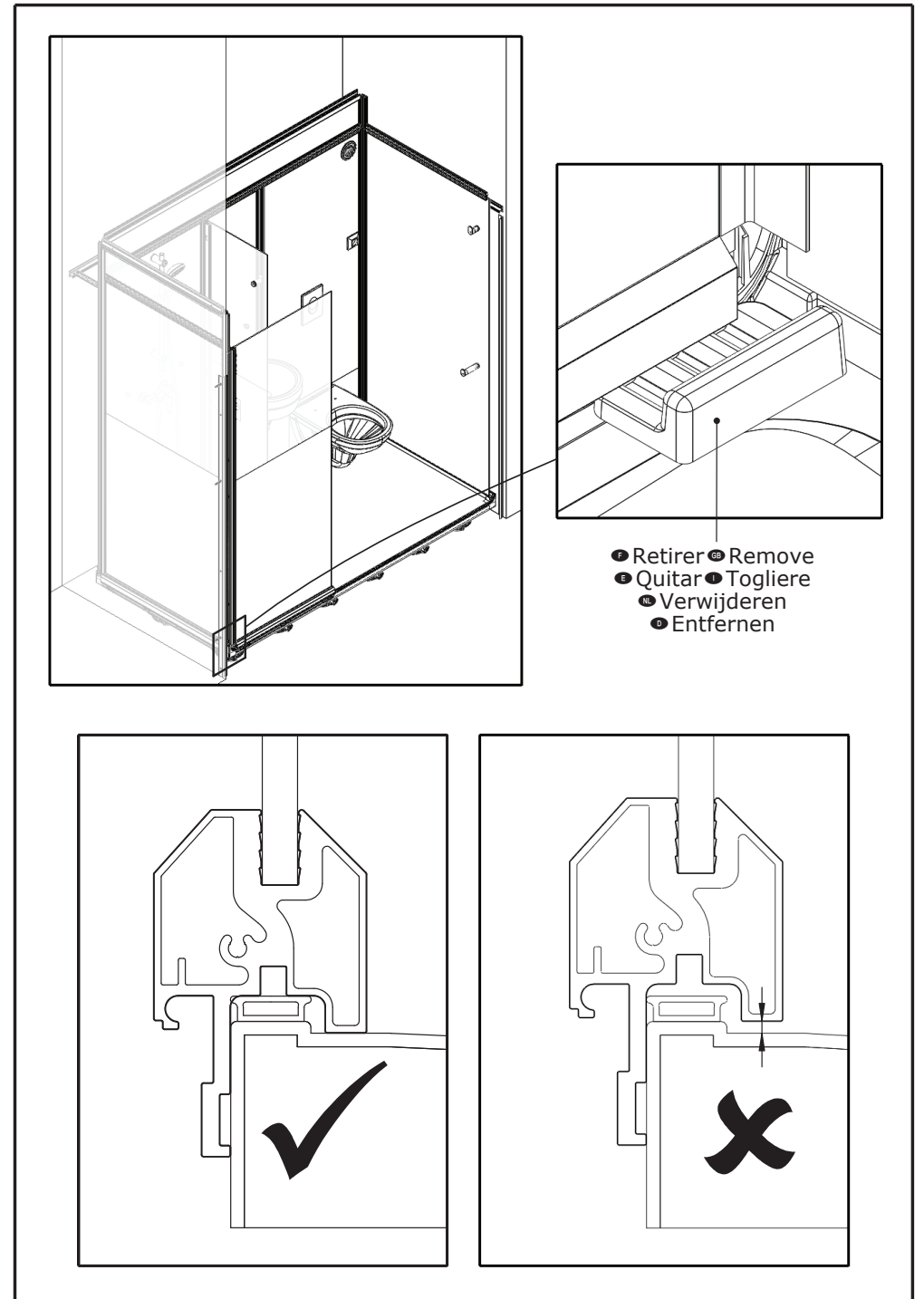
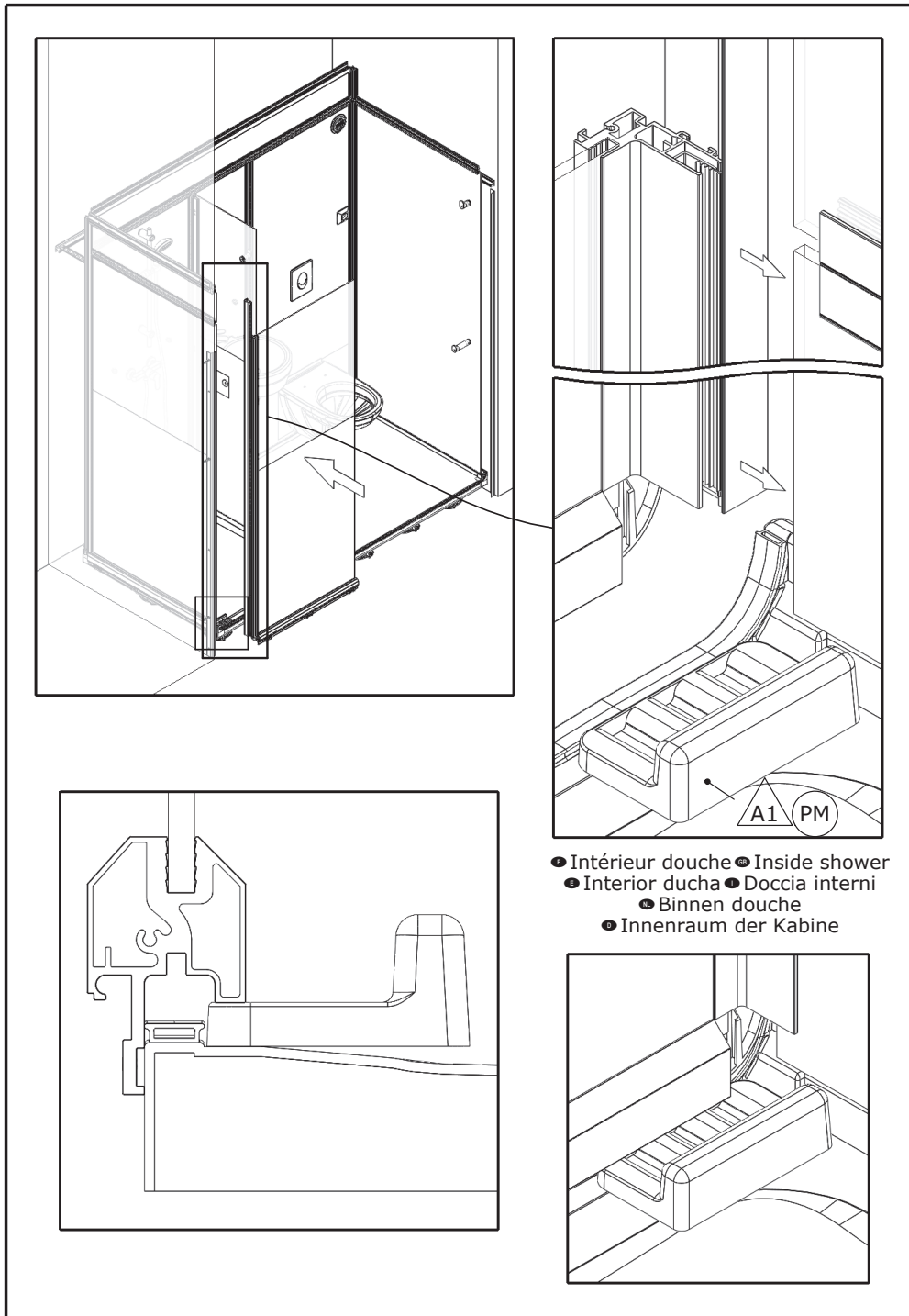

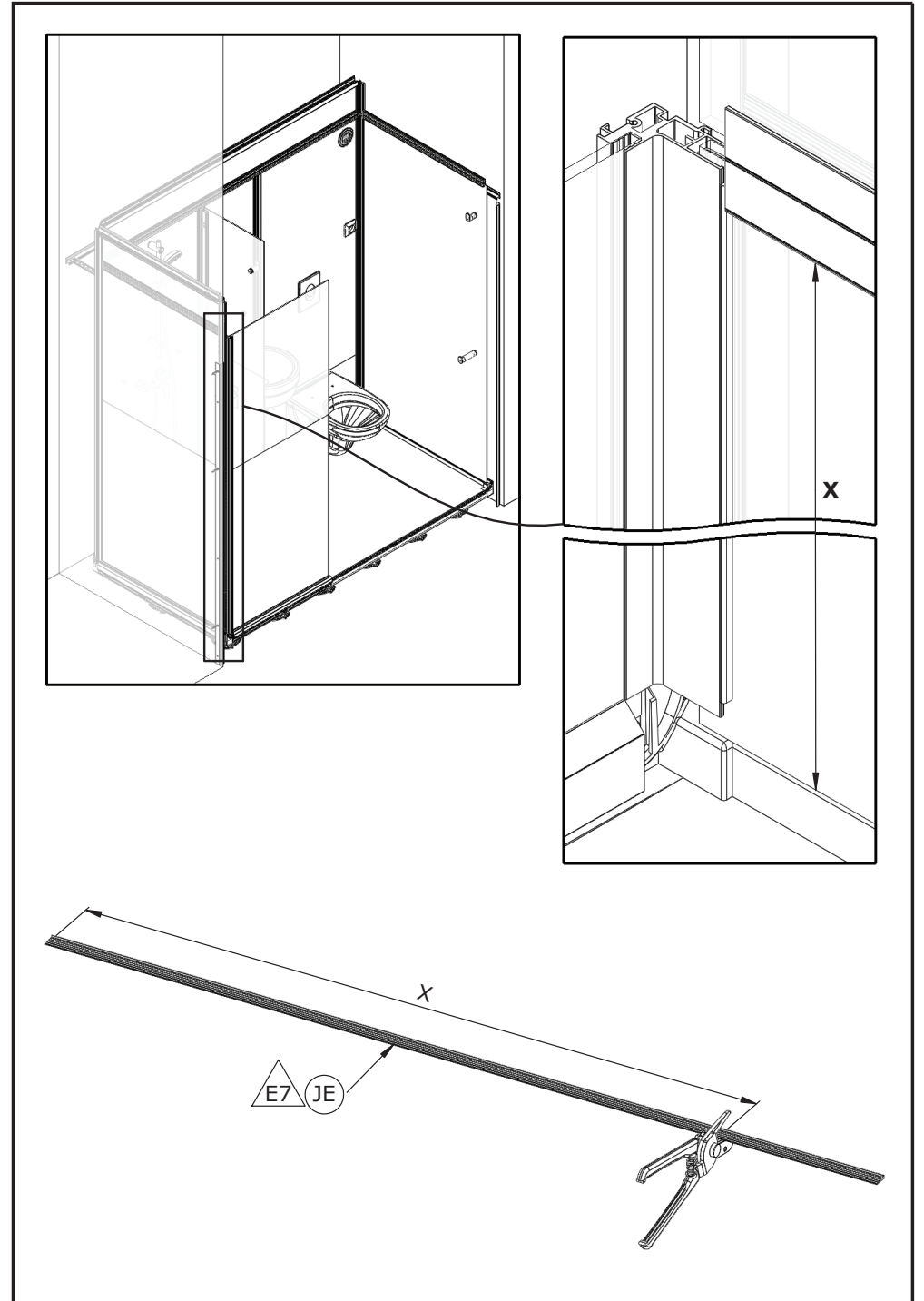
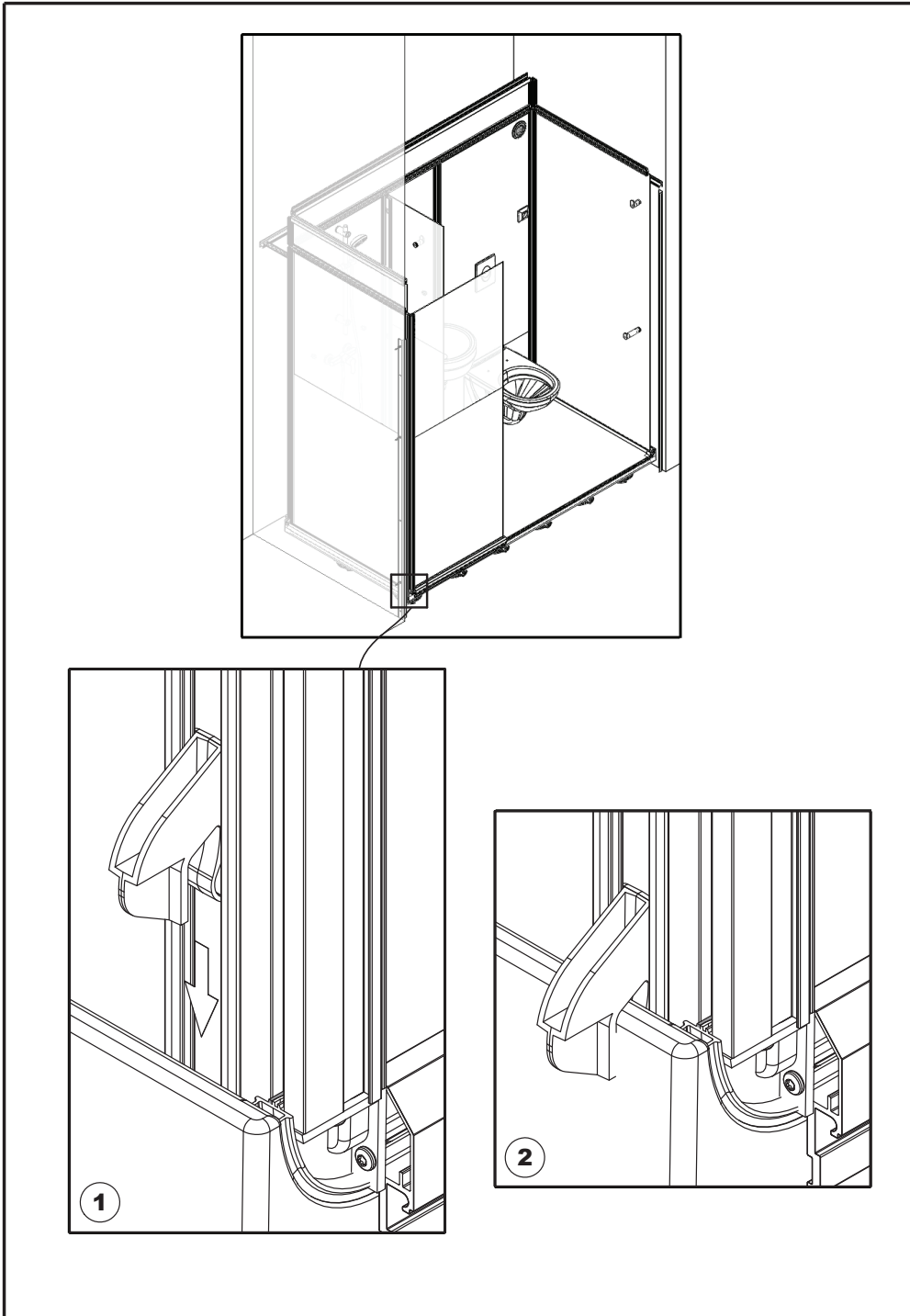

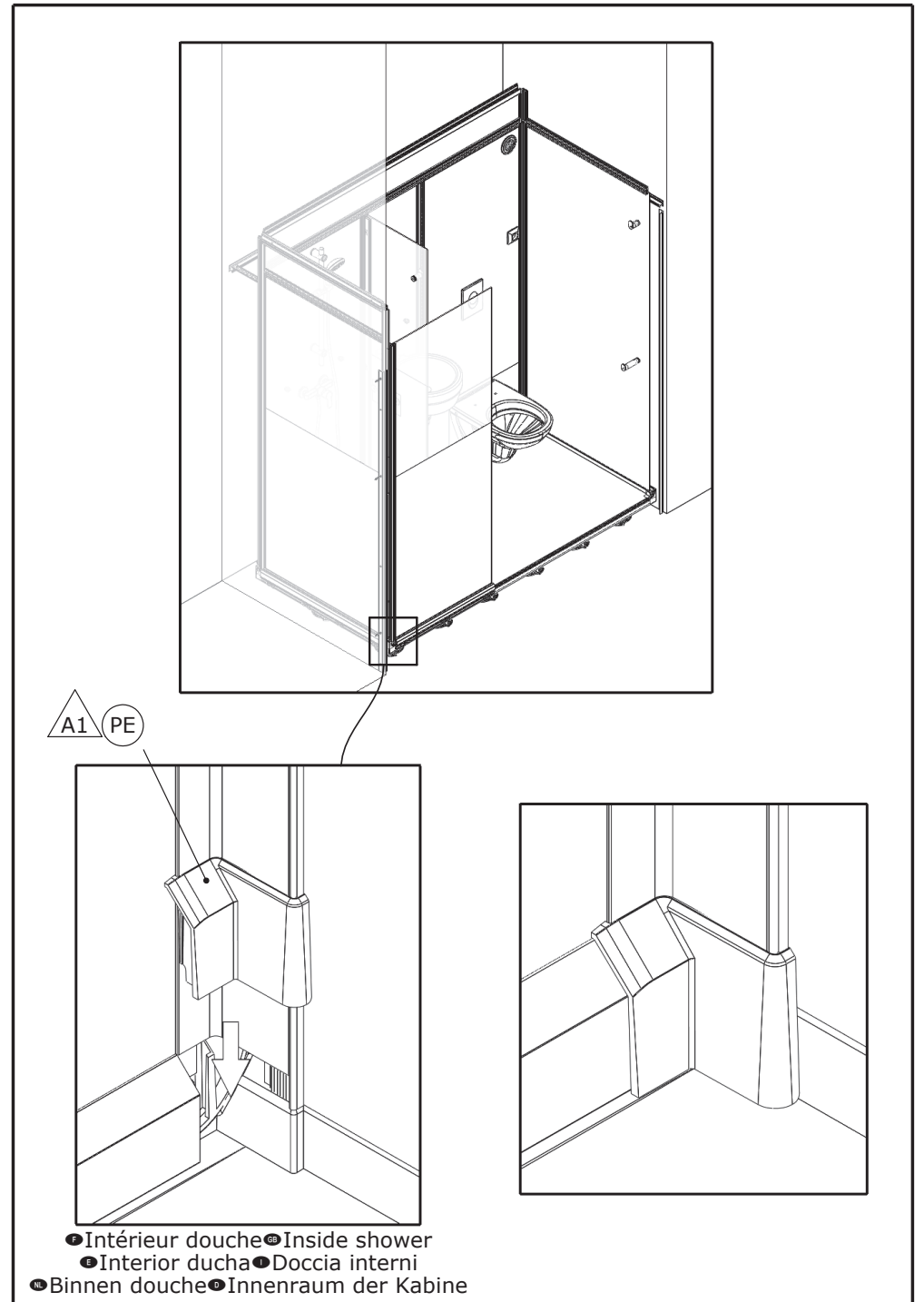
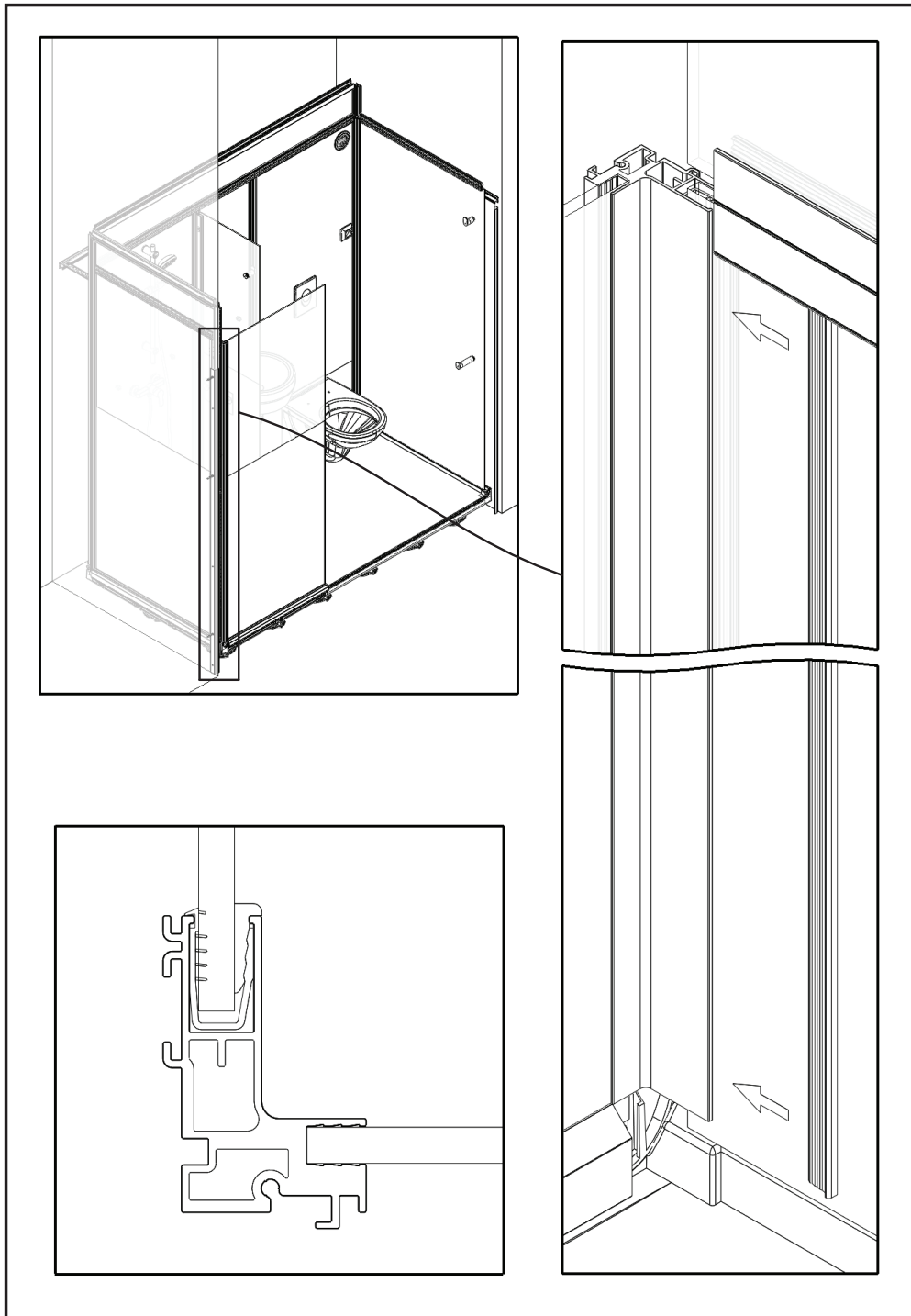



SAV
SERVICE HELPLINES
ASSISTENZA POST-VENDITA
SERVICIO POSTVENTA

| | |
|--|---------------------------------------|
| FRANCE 02 40 21 29 45 | SCHWEIZ (01) 748 17 44 |
| UK 020 8842 0033 | ESPAÑA 93 544 60 76 |
| IRELAND 04697 33102 | NEDERLAND +31 475 487 100 |
| DEUTSCHLAND +49 (0) 6074 / 30928 0 | BELGIË +31 475 487 100 |
| ITALIA (0382) 6181 | BELGIQUE +31 475 487 100 |
| ÖSTEREICH +43 1 710 60 70 | РОССИЯ 963 19 40, 773 67 22 |