

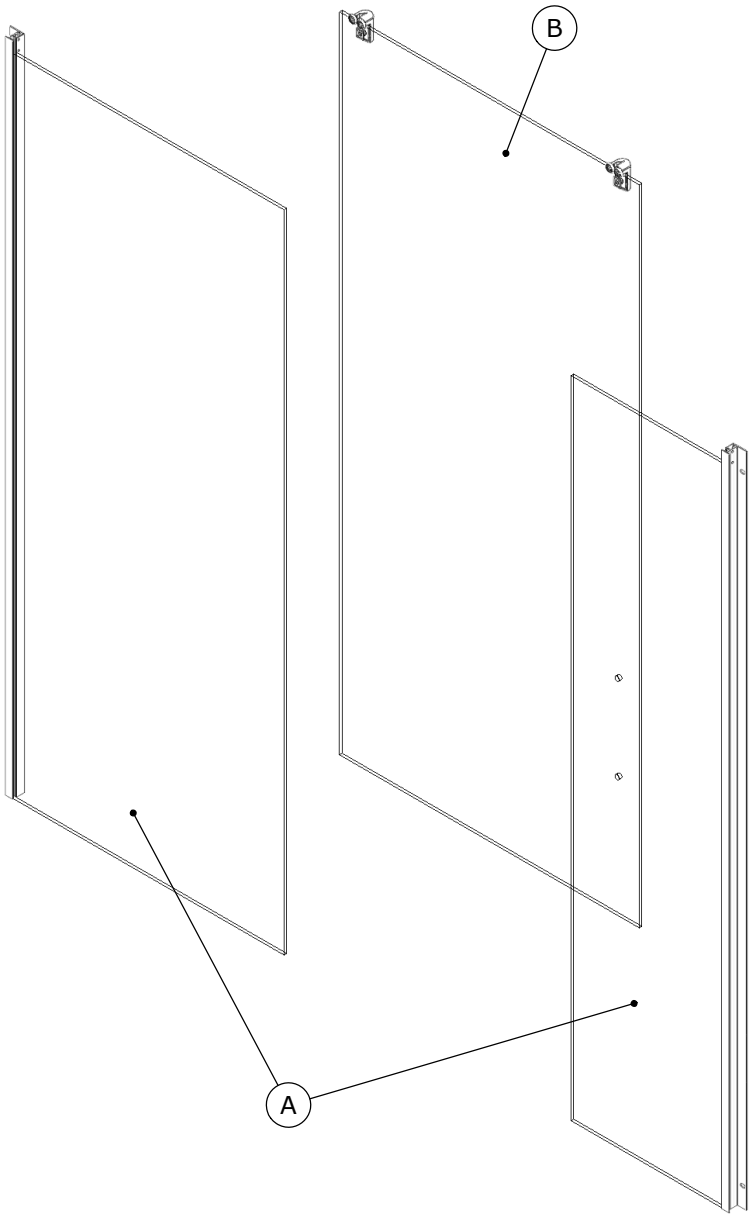







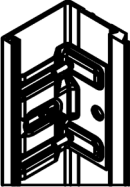

NOTICE DE MONTAGE  
INSTALLATION INSTRUCTIONS  
MANUAL DE INSTALACIÓN  
MANUAL DE INSTALAÇÃO  
ISTRUZIONI DI MONTAGGIO  
INSTALLATIE VOORSCHRIFTEN  
INSTALLATIONSANLEITUNG

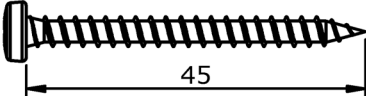

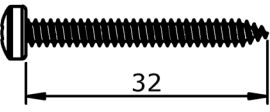
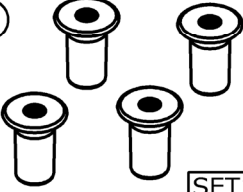

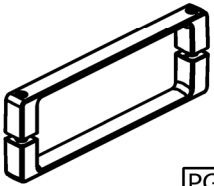
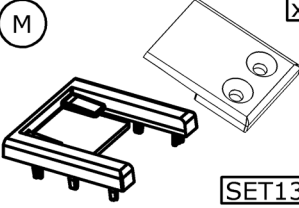
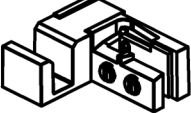
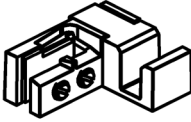
Attention aux étapes :  
Check installation steps :  
Atención a los pasos: P:5 - 14 - 17  
Atenção aos passos: P:5 - 14 - 17  
Attenzione ai passi :  
Aandacht voor de stappen :  
Achtung vor den Schritten :

DES1541C



<p><b>C</b>  <b>x2</b></p> <p>LG=1500mm <b>6268</b></p>	<p><b>D</b>  <b>x1</b></p> <p>LG=1496mm LG=1596mm LG=1696mm <b>6283</b></p>	<p><b>E</b>  <b>x2</b></p> <p>LG=1500mm <b>6270</b></p>
<p><b>F</b>  <b>Ø3,5mm</b> <b>x4</b></p> <p>45</p> <p><b>VIS231</b></p>	<p><b>G</b>  <b>x4</b></p> <p><b>CHE02</b></p>	<p><b>I</b>  <b>Ø3,5mm</b> <b>x2</b></p> <p>9,50</p> <p><b>VIS261</b></p>
<p><b>H</b>  <b>Ø3,5mm</b> <b>x4</b></p> <p>32</p> <p><b>VIS214</b></p>	<p><b>J</b>  <b>x4</b></p> <p><b>SET134</b></p>	<p><b>K</b>  <b>x2</b></p> <p><b>SET135</b></p>
<p><b>L</b>  <b>x1</b></p> <p><b>PGN49</b></p>	<p><b>M</b>  <b>x2</b></p> <p><b>SET137</b></p>	<p><b>N</b>  <b>x1</b></p> <p><b>SET130</b></p>
<p><b>O</b>  <b>x1</b></p> <p><b>SET131</b></p> <p>Ou - Or O - Ou - O Of - Oder</p>	<p><b>P</b>  <b>x1</b></p> <p><b>JOI258</b></p>	<p><b>Q</b>  <b>x1</b></p> <p>LG=1460mm <b>J926</b></p>
<p><b>R</b>  <b>x1</b></p> <p>LG=1448mm <b>J930</b></p>		

Les quantités données sont les quantités utiles au montage. les sachets fournis contiennent des pièces supplémentaires.  
 The quantities given are what are required for the installation. There may be some surplus in the package provide.  
 Las cantidades indicadas son las cantidades necesarias para el montaje. Las bolsitas incluidas contienen piezas suplementarias.  
 As quantidades indicadas são as quantidades necessárias para a montagem. Os sacos fechados contém peças adicionais.  
 Le quantità fornite sono le quantità necessarie al montaggio. I sacchetti forniti contengono pezzi supplementari.  
 De aangegeven aantallen zijn vereist voor de montage. De verpakking bevat extra onderdelen.  
 Die Mengenangaben beziehen sich auf die für die Montage nötigen Teile. Eventuell weitere beige packte Teile ignorieren.

(S)	(x1)	(T)	(x1)	(U)	(x1)
					
JOI317	LG=1459mm	AI203	LG=1465mm	AI204	

.Les quantités données sont les quantités utiles au montage. les sachets fournis contiennent des pièces supplémentaires.  
 .The quantities given are what are required for the installation. There may be some surplus in the package provide.  
 .Las cantidades indicadas son las cantidades necesarias para el montaje. Las bolsitas incluidas contienen piezas suplementarias.  
 .As quantidades indicadas são as quantidades necessárias para a montagem. Os sacos fechados contém peças adicionais.  
 .Le quantità fornite sono le quantità necessarie al montaggio. I sacchetti forniti contengono pezzi supplementari.  
 .De aangegeven aantallen zijn vereist voor de montage. De verpakking bevat extra onderdelen.  
 .Die Mengenangaben beziehen sich auf die für die Montage nötigen Teile. Eventuell weitere beige packte Teile ignorieren.

**Matériel nécessaire - Tools required**  
**Equipamiento necesario - Equipamento necessário**  
**Materiale necessario - Benodigd gereedschap - Benötigte Werkzeuge**

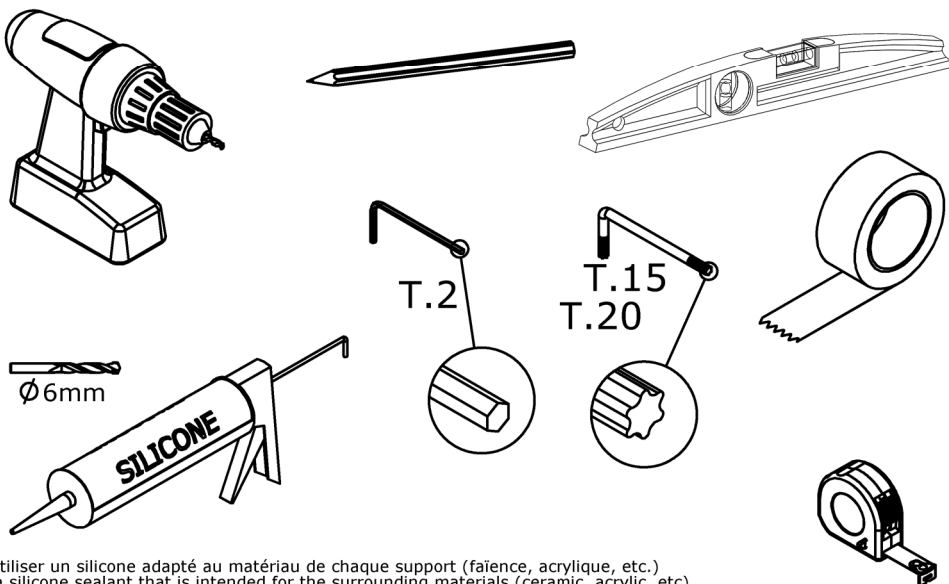

Utiliser un silicone adapté au matériau de chaque support (faïence, acrylique, etc.)  
 Use a silicone sealant that is intended for the surrounding materials (ceramic, acrylic, etc.)  
 Usar una silicona adecuada para cada tipo de material (loza, acrílico, etc.)  
 Usar una silicona adecuada para cada tipo de material (loza, acrílico, etc.)  
 Utilizzare un silicone adatto a qualsiasi materiale (ceramica, acrilico, ecc.)  
 Gebruik siliconenkit die geschikt is voor iedere ondergrond (tegelwerk, acryl, etc.)  
 Für das jeweilige Trägermaterial (Stein, Acryl usw.) geeignetes Silikon verwenden.





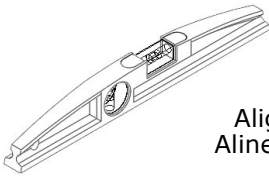
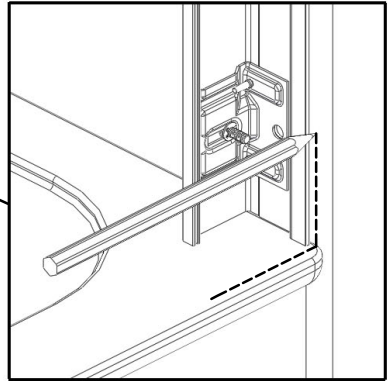
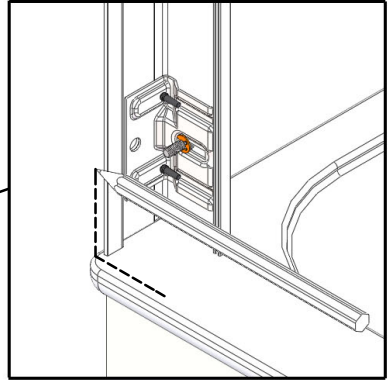
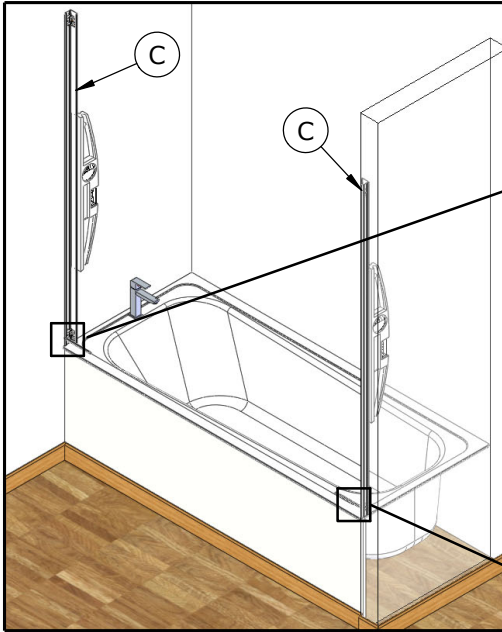

Aligner les profiles - Align profiles  
 Alinear los perfiles - Alinhar os perfis  
 Allineare i profili

Profielen uitlijnen - Richten Sie die Profile aus

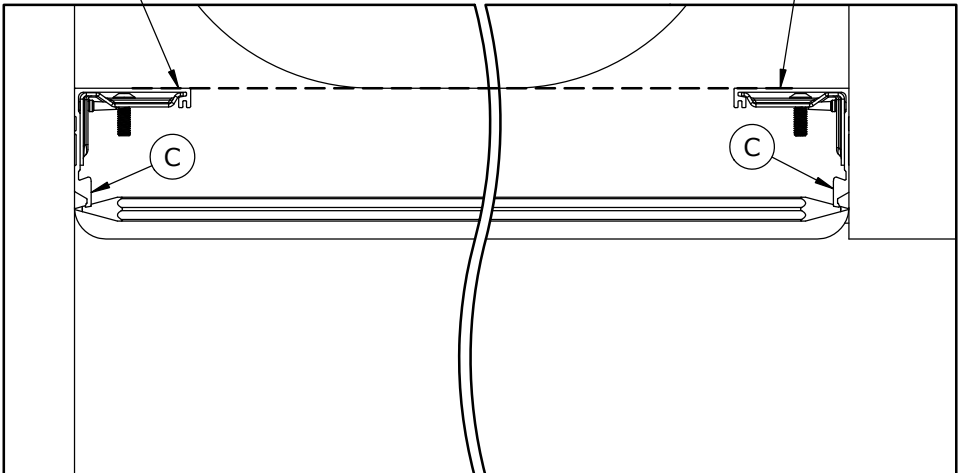

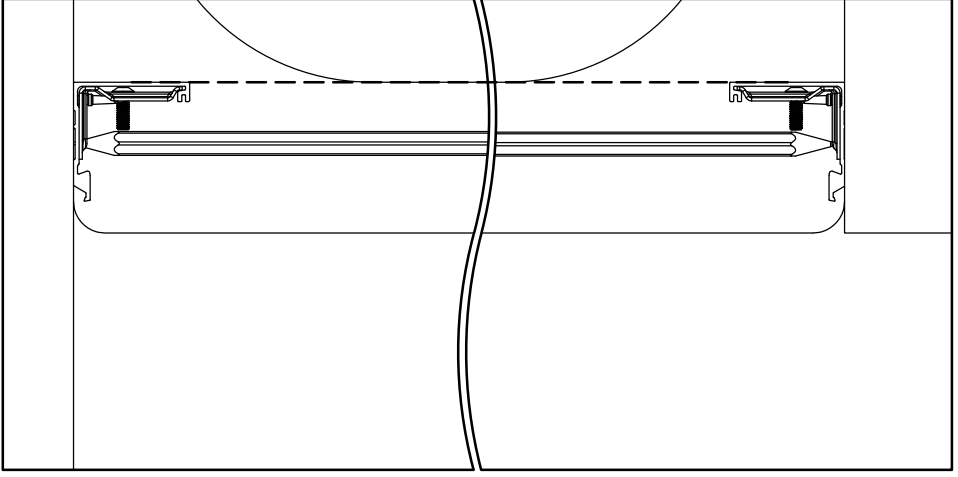
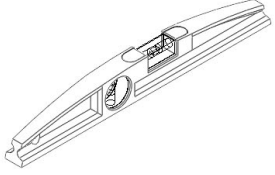
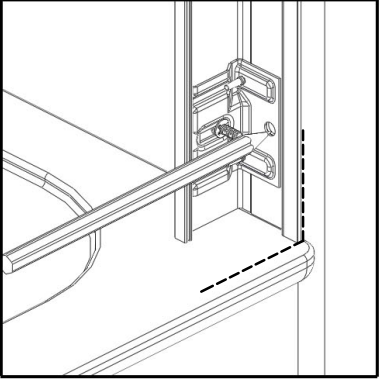
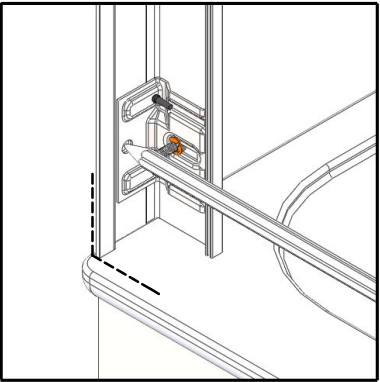
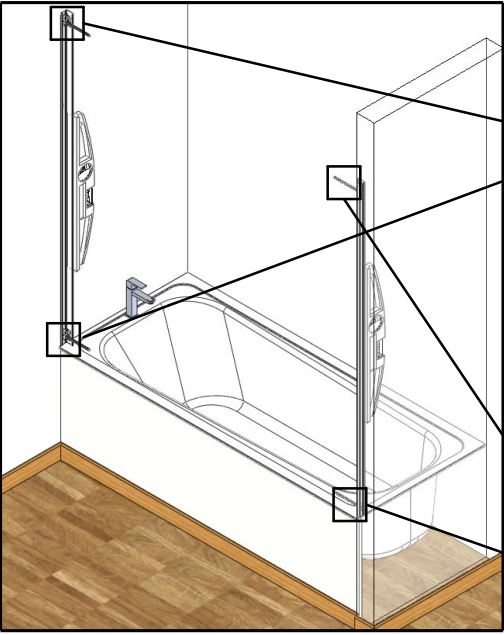

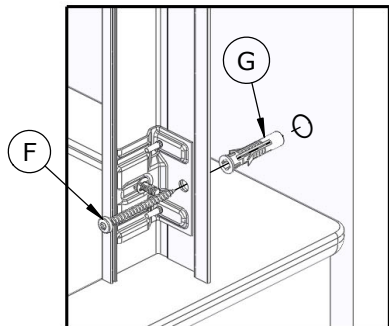
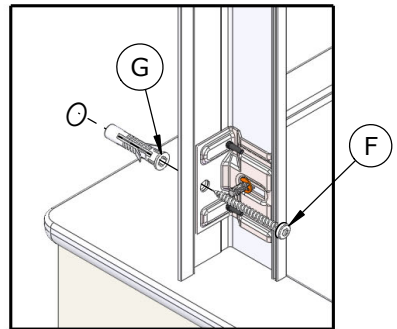
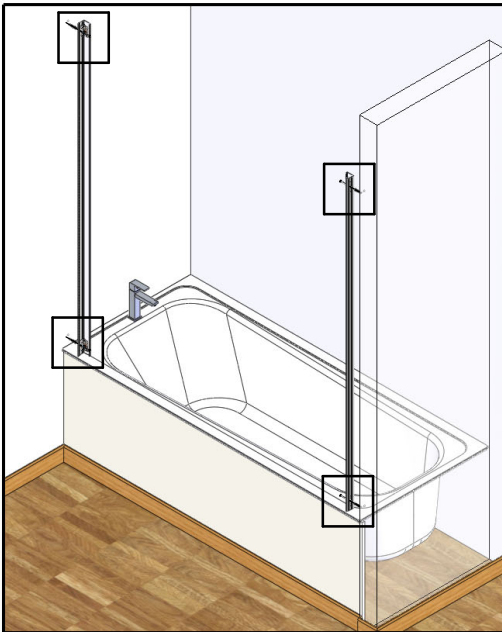
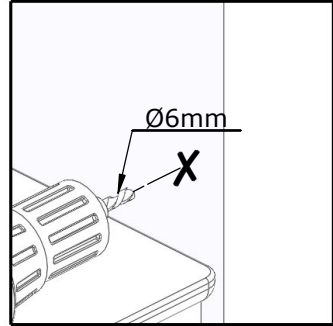
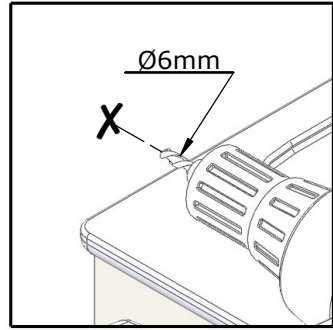
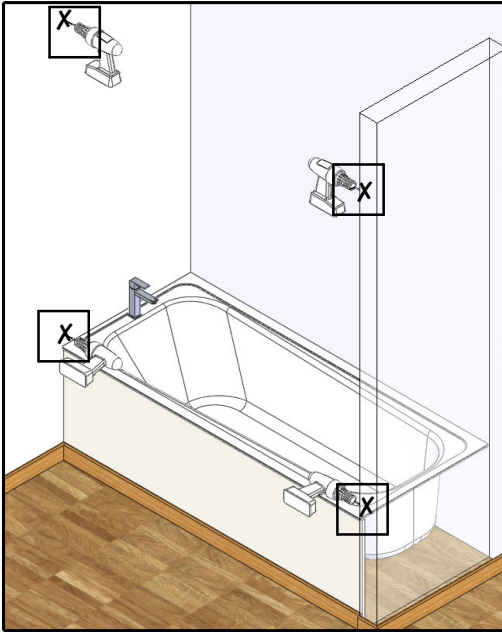

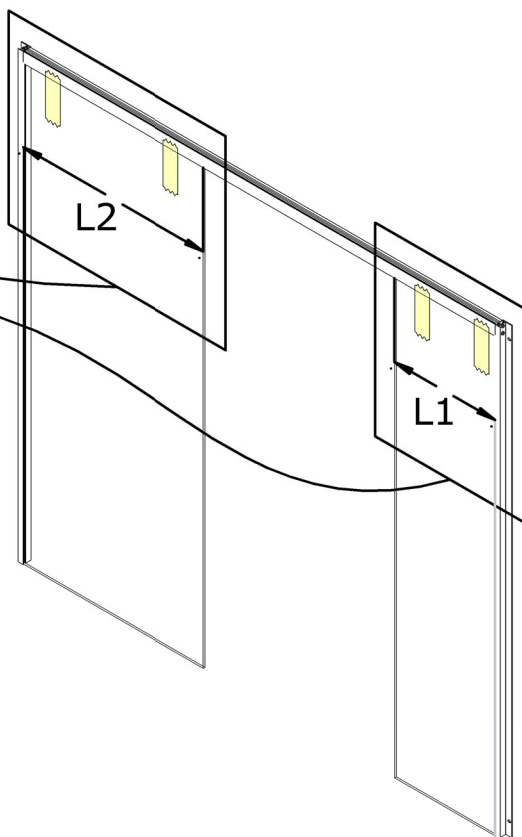
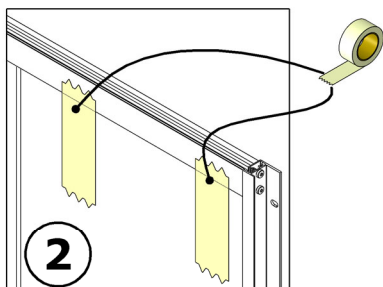
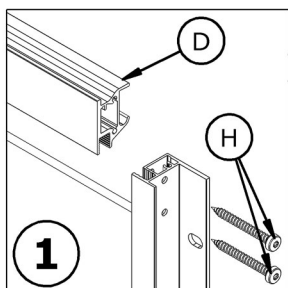
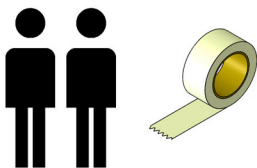

Extérieur - Outside - Exterior -  
Exterior  
- Esterno - Buienkant - Außen

	Taille - mesure Medida - Misura Maat - Größe (mm)	S	
		L1	L2
	1600	258	588
	1700		688
	1800		688

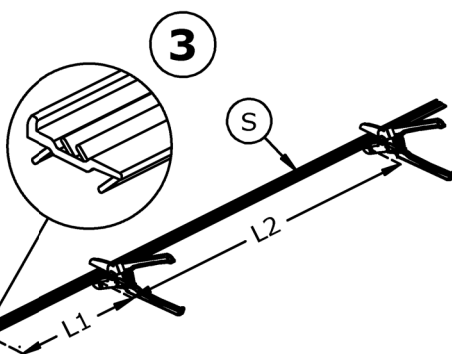

Intérieur  
Inside  
Interno  
Interior  
Interno  
Binnenkant  
Innen

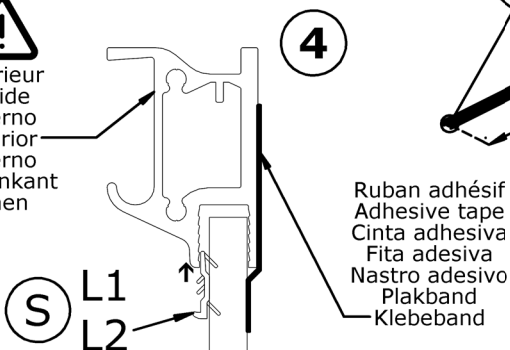

Ruban adhésif  
Adhesive tape  
Cinta adhesiva  
Fita adesiva  
Nastro adesivo  
Plakband  
Klebeband

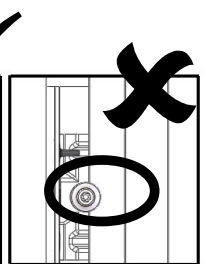
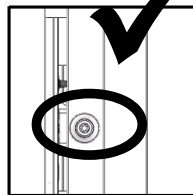
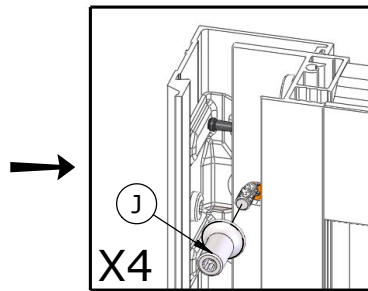
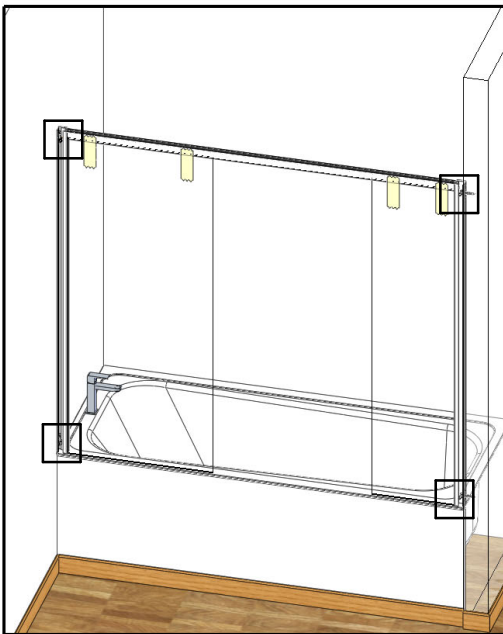
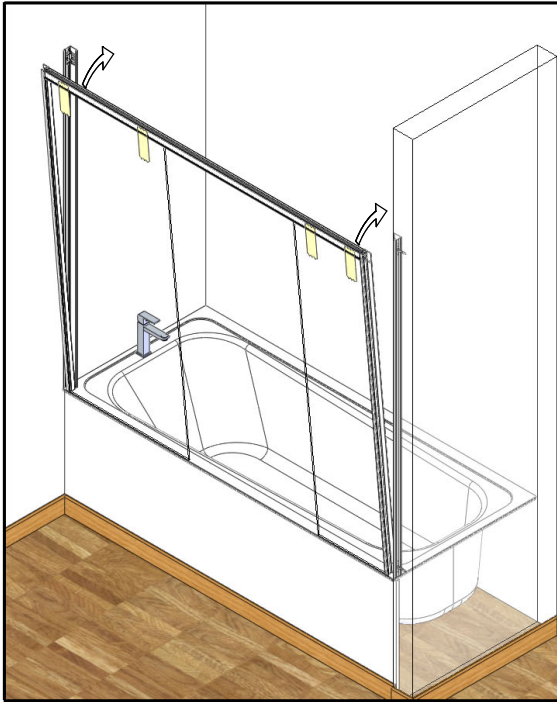
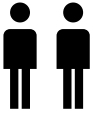

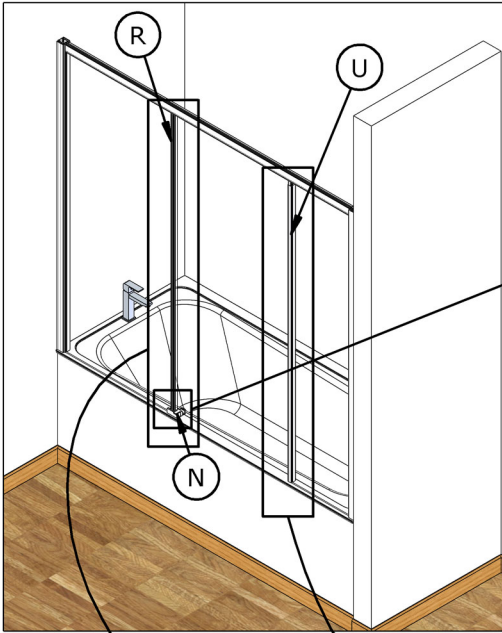

1

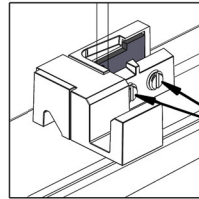
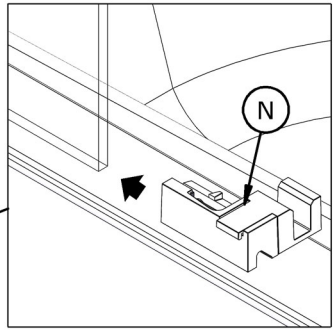

Serrer  
Tighen  
Apriete  
Apertar  
Serrare  
Vastdraaien  
Festziehen

Intérieur - Inside  
Interno - Interior  
Ineterno  
Binnenkant - Innen

2

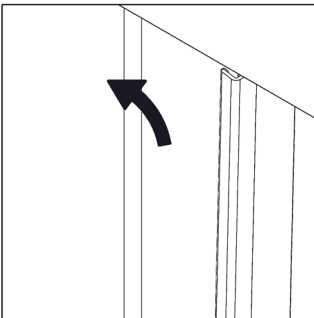
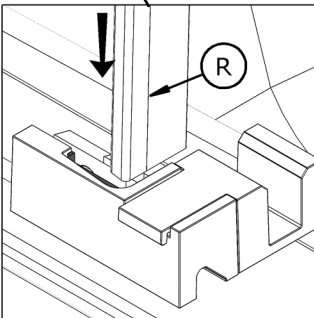

3

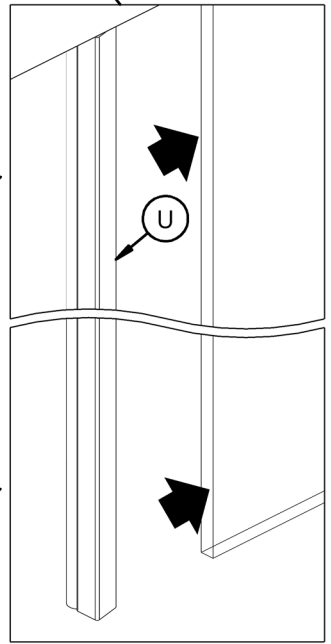

Intérieur - Inside  
Interno - Interior  
Ineterno  
Binnenkant - Innen

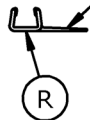

Intérieur - Inside  
Interno - Interior  
Ineterno  
Binnenkant - Innen



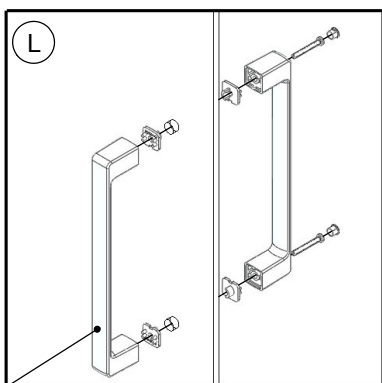
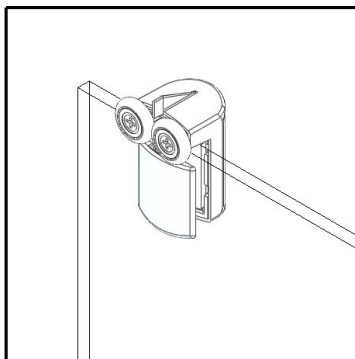
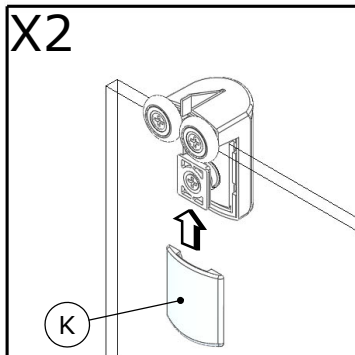
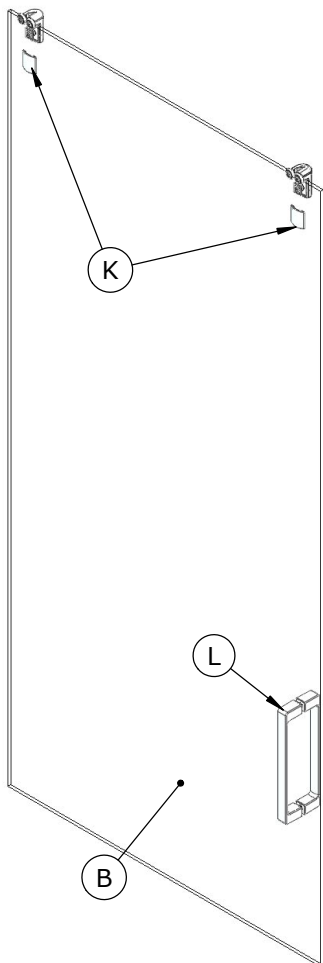

↳ Extérieur - Outside - Exterior - Exterior  
 - Esterno - Buienkant - Außen

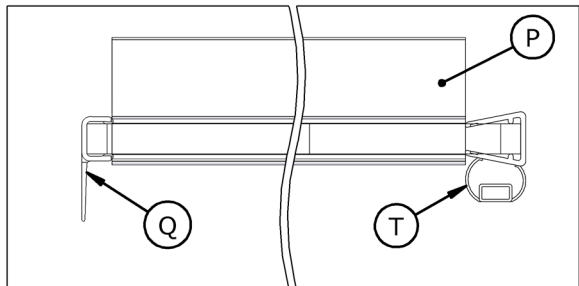
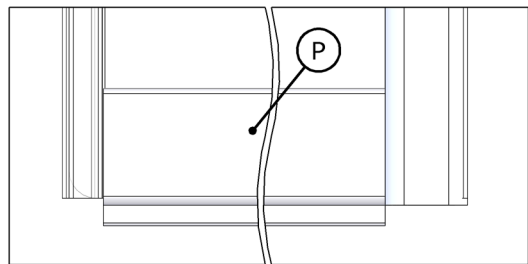
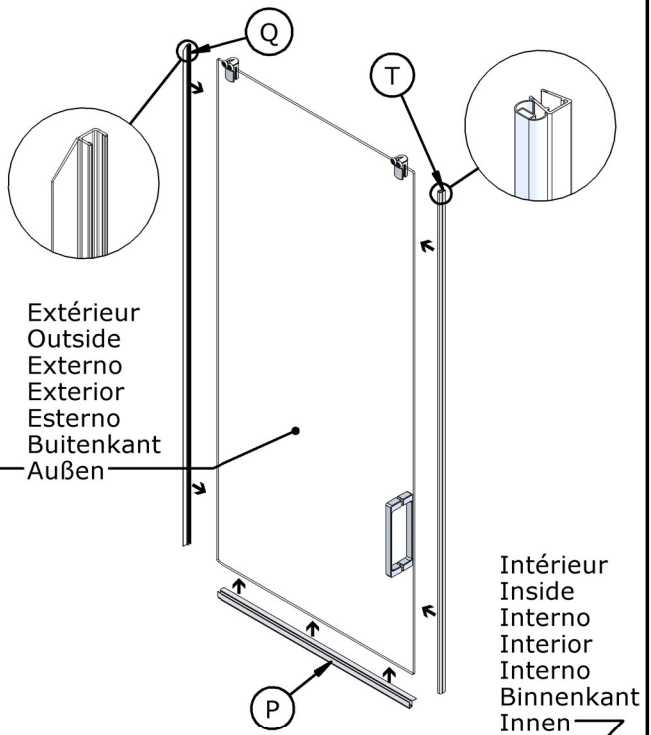
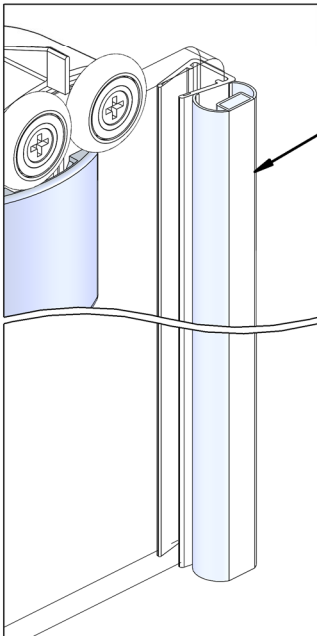
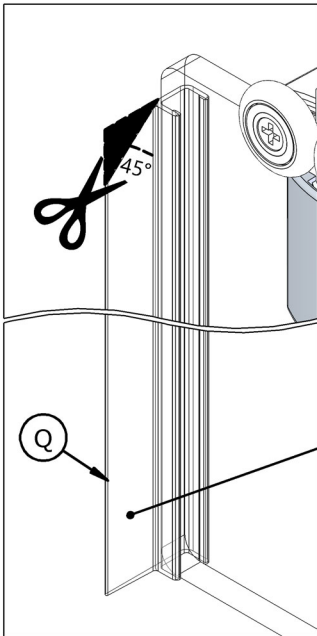



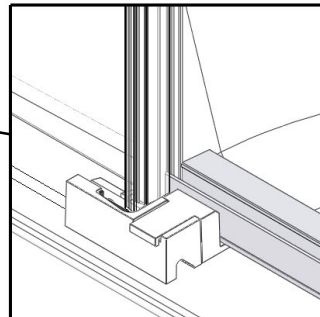
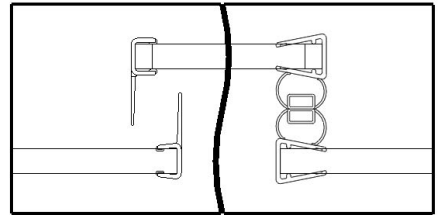
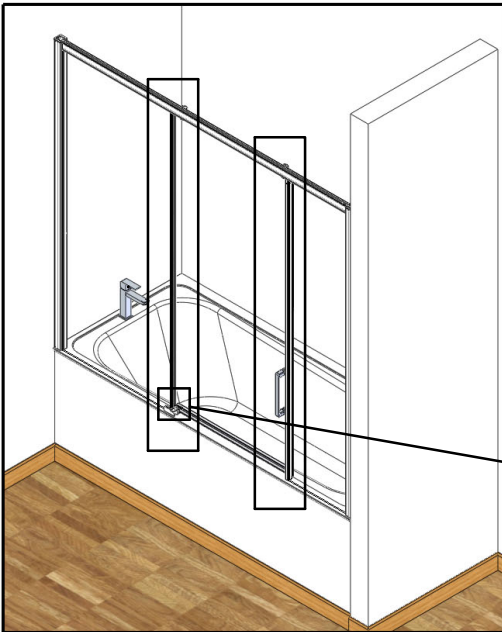
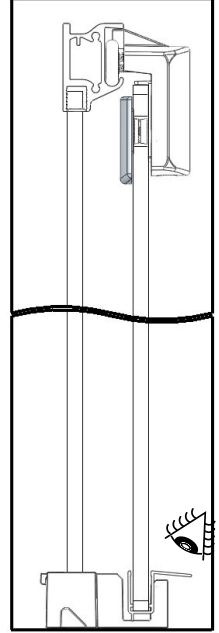
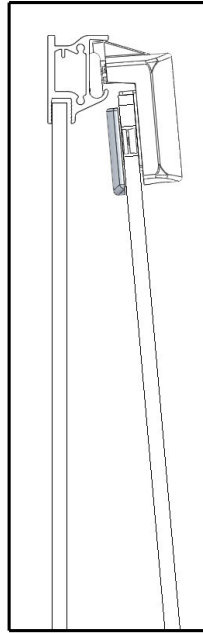
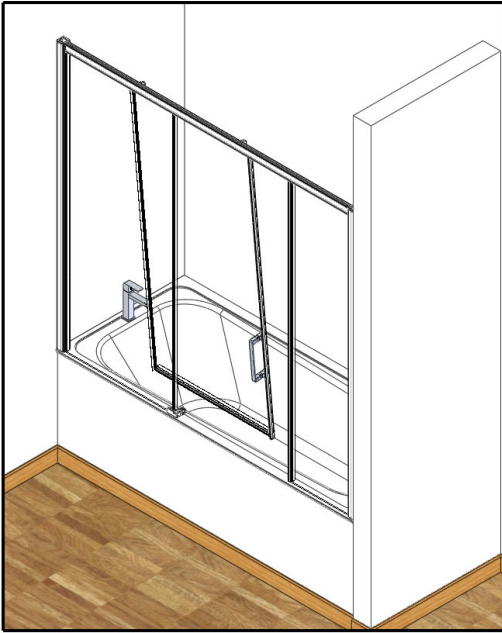



Réglage de la porte  
 Door adjustment  
 Ajuste de la puerta  
 Ajuste da porta  
 Regolazione porta  
 Afstellen van de deur  
 Einstellen der Tür

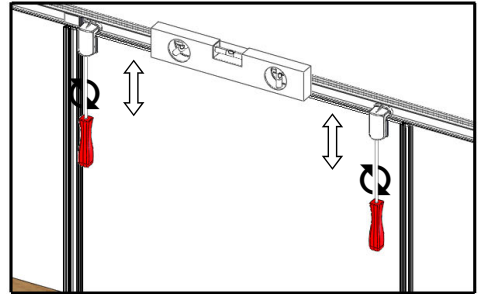

Intérieur - Inside Interno - Interior  
 Inetno - Binnenkant - Innen

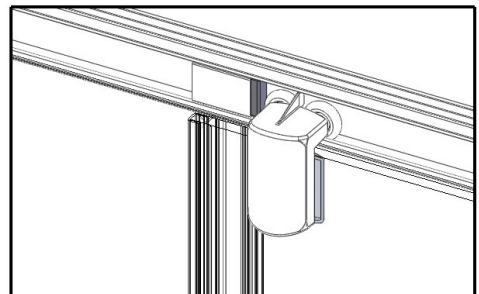
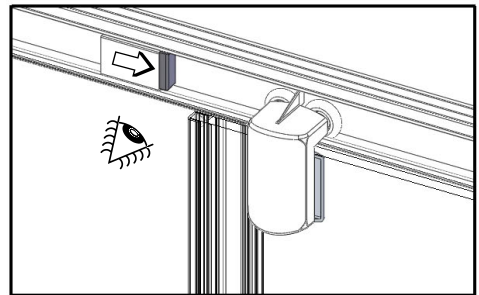
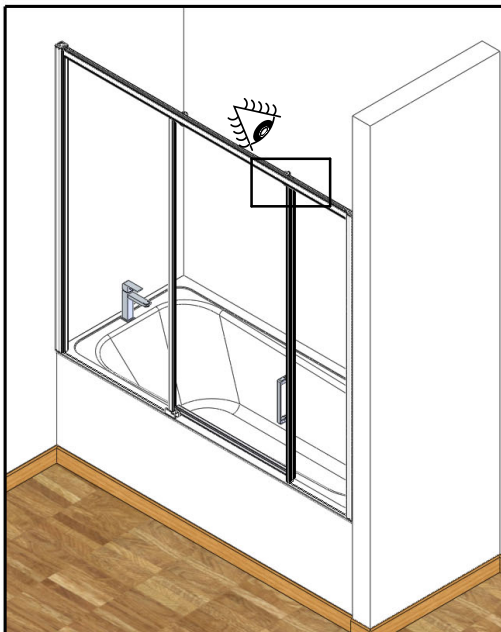

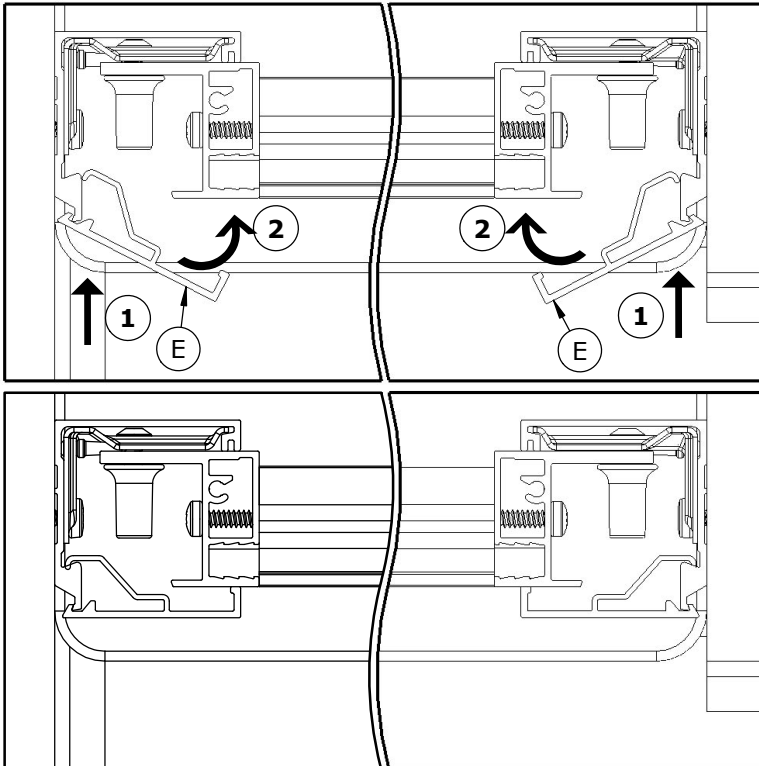
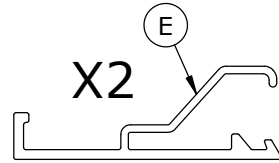
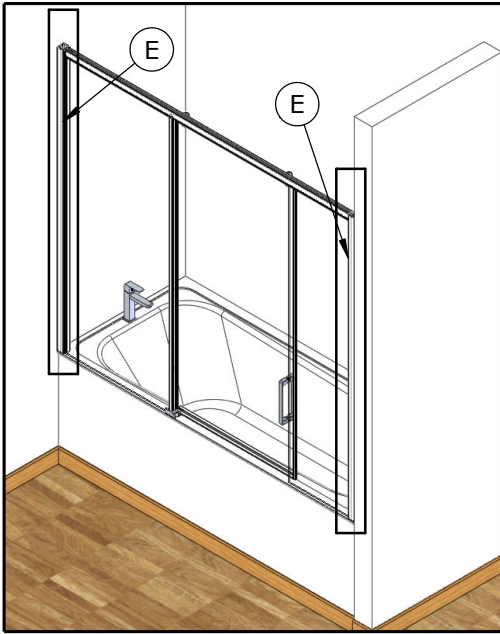

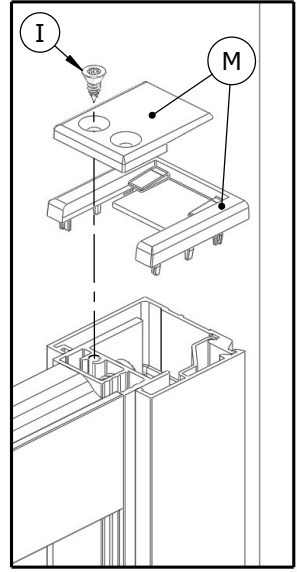
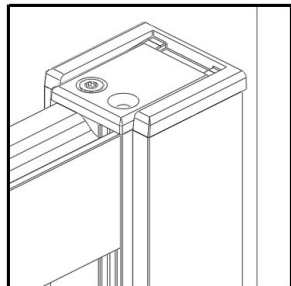
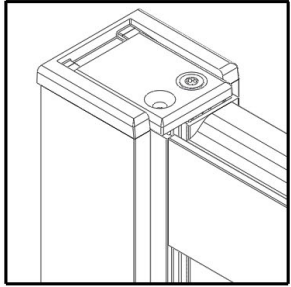
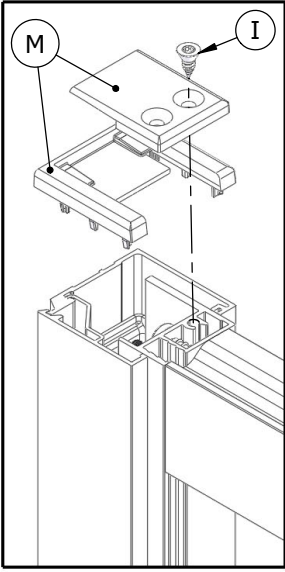
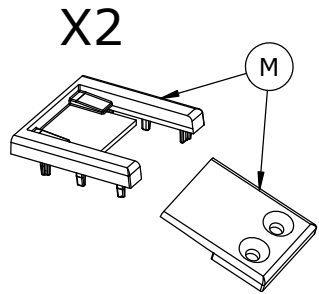
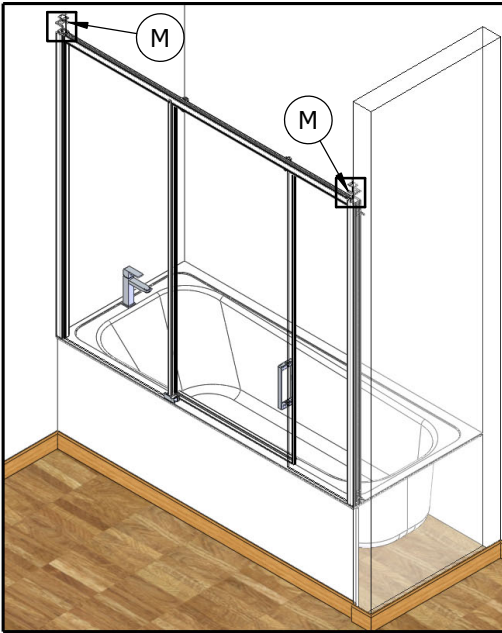

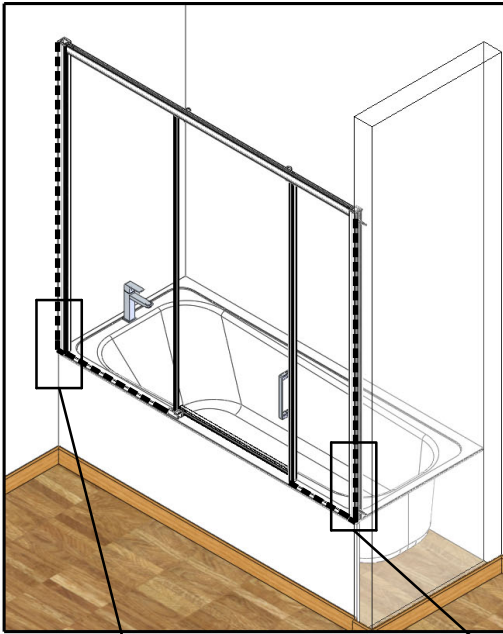

24h

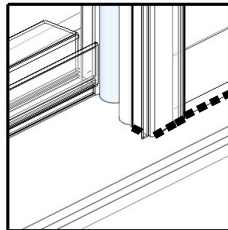
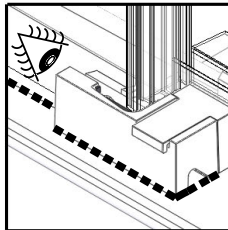
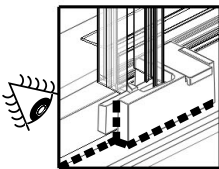
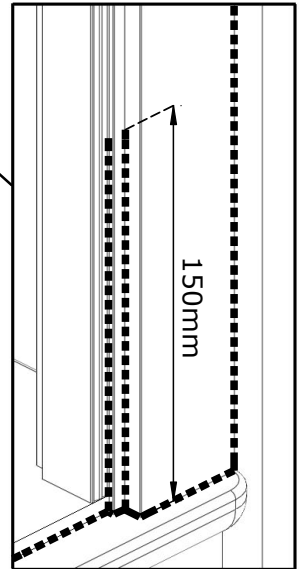
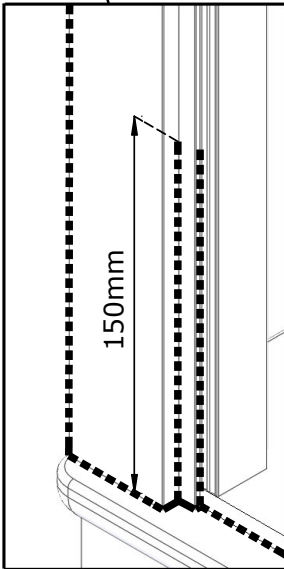
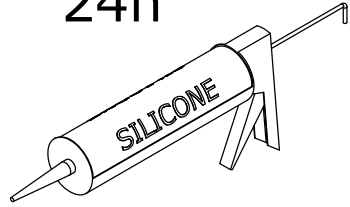



**NOTICE D'ENTRETIEN  
MAINTENANCE INSTRUCTIONS  
ISTRUZIONI DI MANUTENZIONE  
INSTRUCCIONES DE MANTENIMIENTO  
ONDERHOUDSINSTRUCTIE  
WARTUNGSANLEITUNG**

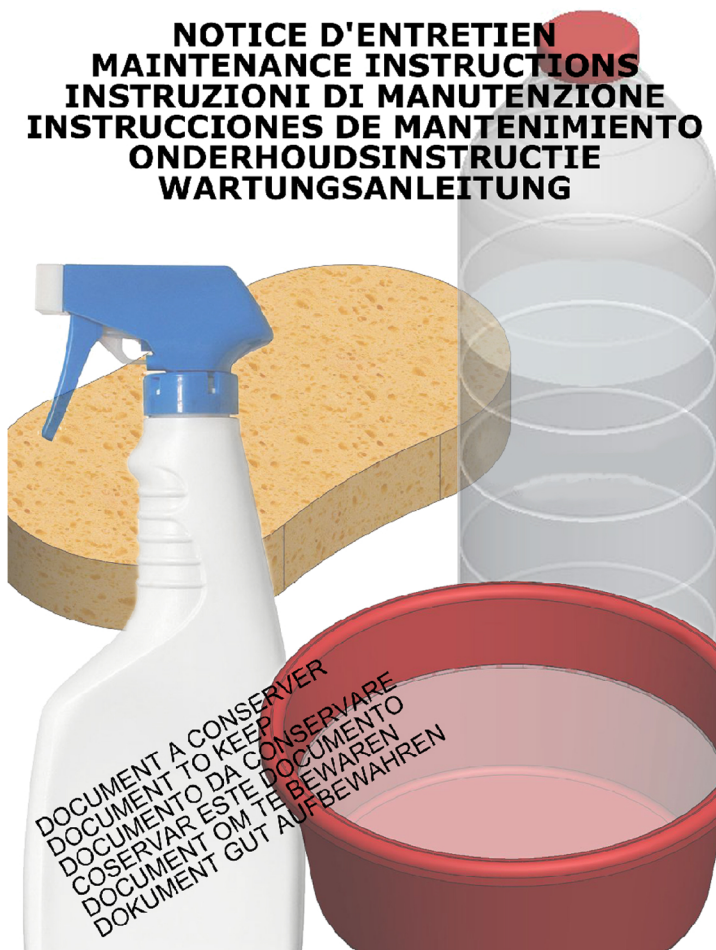

**SCAN ME**





## SERVICE APRÈS-VENTE AFTER-SALES SERVICE

### FRANCE

+33 (0)2 40 21 29 45

### UK

+44 020 8842 0033

### IRELAND

+353 04697 33102

### DEUTSCHLAND

+49 (0) 6074 / 30928 0

### ITALIA

+39 (0382) 6181

### ÖSTEREICH

+43 1 710 60 70

### SUISSE/SCHWEIZ

+41 (01) 748 17 44

### ESPAÑA

+34 93 544 60 76

### NEDERLAND

+31 475 487 100

### BELGIQUE/BELGIË

+31 475 487 100

### РОССИЯ

+7 495 258-29-51

### PORTUGAL

+351 219 112 785



AQUAPRODUCTION, Site industriel,  
F - 44680 Chaumes-en-Retz

22

### EN 14428

Paroi de douche, fabriquée en verre de silicate  
sodo-calcique de sécurité trempé thermiquement

Aptitude au nettoyage : réussite

Résistance à l'impact/propriétés de fragmentation : réussite

Durabilité : réussite