

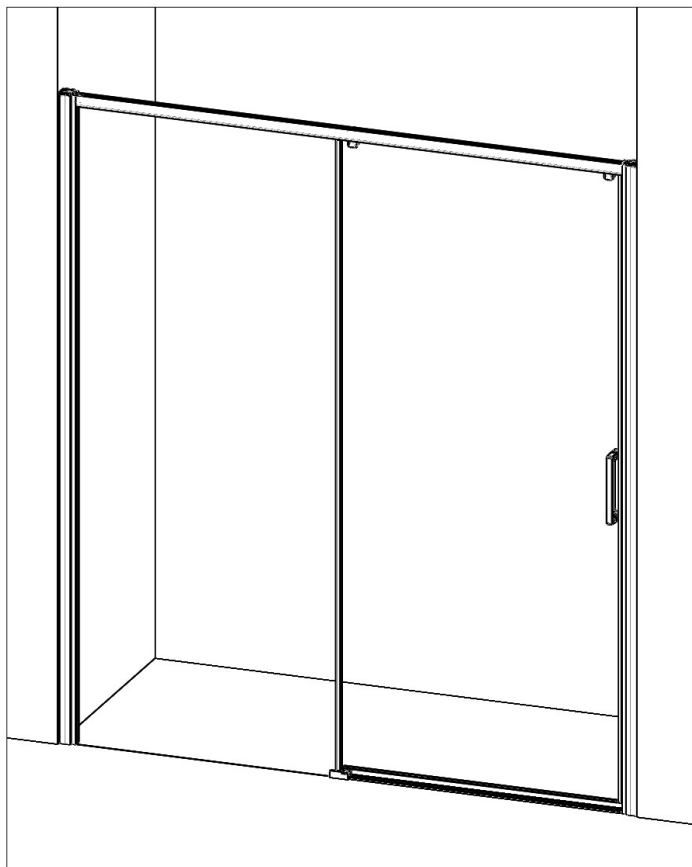

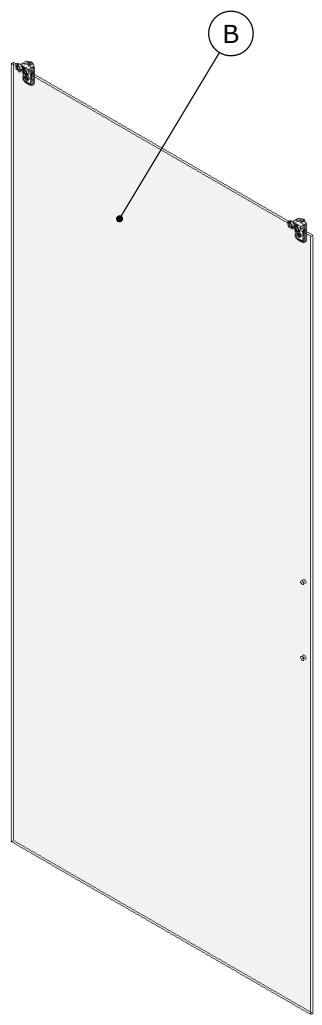

# Kinedo

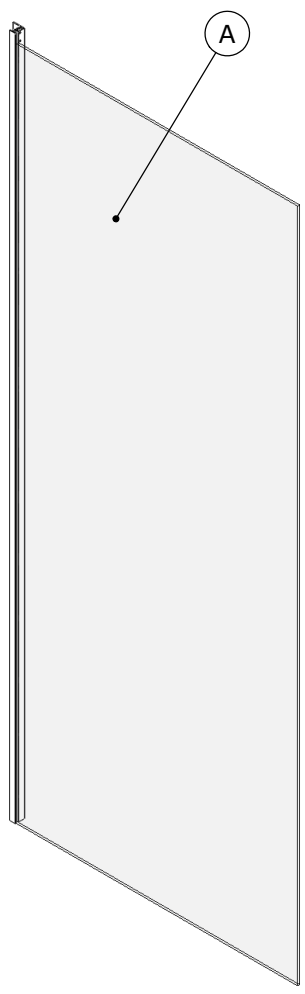
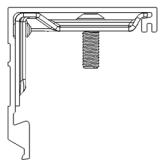
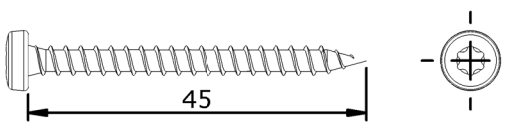
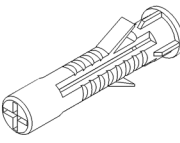
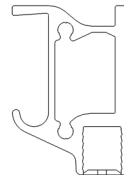
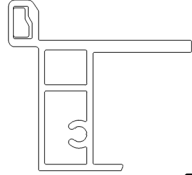
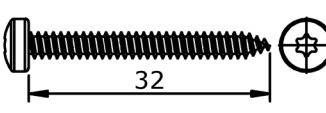
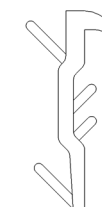
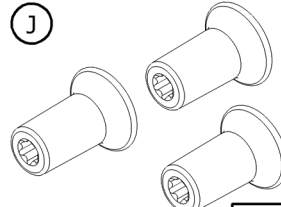

Notre service technique est  
à votre écoute aux numéros  
qui sont au dos de cette  
notice d'installation

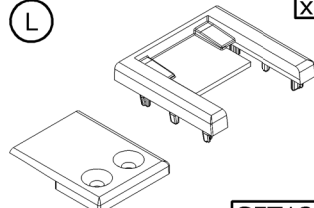
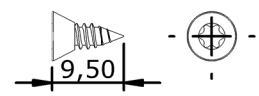
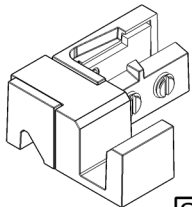
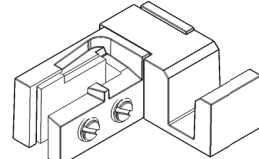
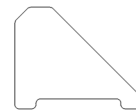
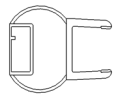

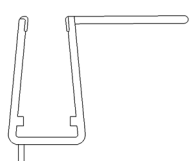
<p><b>C</b> <span style="float: right;">x2</span></p>  <p style="text-align: right;"><b>6268</b></p>	<p><b>D</b> <span style="float: right;">Ø4</span> <span style="float: right;">x6</span></p>  <p style="text-align: right;"><b>VIS231</b></p>	
<p><b>E</b> <span style="float: right;">x6</span></p>  <p style="text-align: right;"><b>CHE02</b></p>	<p><b>F</b> <span style="float: right;">x1</span></p>  <p style="text-align: right;"><b>6283</b></p>	<p><b>G</b> <span style="float: right;">x1</span></p>  <p style="text-align: right;"><b>6279</b></p>
<p><b>H</b> <span style="float: right;">Ø3.5</span> <span style="float: right;">x4</span></p>  <p style="text-align: right;"><b>VIS214</b></p>	<p><b>I</b> <span style="float: right;">x1</span></p>  <p style="text-align: right;">Lg=803mm <b>J809</b></p>	<p><b>J</b> <span style="float: right;">x2</span></p>  <p style="text-align: right;"><b>SET134</b></p>
<p><b>K</b> <span style="float: right;">x2</span></p>  <p style="text-align: right;"><b>6270</b></p>	<p><b>L</b> <span style="float: right;">x2</span></p>  <p style="text-align: right;"><b>SET137</b></p>	<p><b>M</b> <span style="float: right;">Ø3.5</span> <span style="float: right;">x2</span></p>  <p style="text-align: right;"><b>VIS261</b></p>
<p><b>N</b></p>  <p style="text-align: right;"><b>SET130</b></p>	<p><b>O</b> <span style="float: right;">x1</span></p>  <p style="text-align: right;"><b>SET131</b></p>	<p><b>P</b> <span style="float: right;">x1</span></p>  <p style="text-align: right;"><b>6285</b></p>
<p><b>P</b> <span style="float: right;">x1</span></p>  <p style="text-align: right;">Lg=1949mm <b>AI171</b></p>	<p><b>Q</b> <span style="float: right;">x1</span></p>  <p style="text-align: right;">Lg=1969mm <b>J782</b></p>	<p><b>R</b> <span style="float: right;">x1</span></p>  <p style="text-align: right;">Lg=950mm <b>J780</b></p>

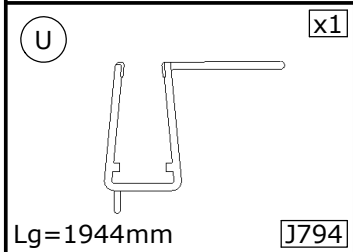
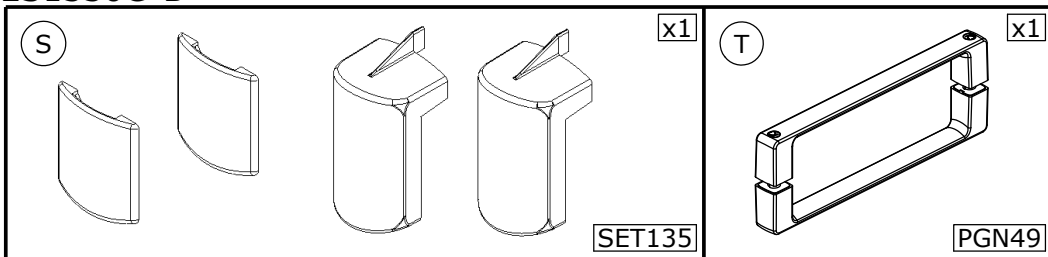

- Les quantités données sont les quantités utiles au montage. les sachets fournis contiennent des pièces supplémentaires.
  - The quantities given are what are required for the installation. There may be some surplus in the package provide.
- Las cantidades indicadas son las cantidades necesarias para el montaje. Las bolsitas incluidas contienen piezas suplementarias.
  - Le quantità fornite sono le quantità necessarie al montaggio. I sacchetti forniti contengono pezzi supplementari.
  - De aangegeven aantallen zijn vereist voor de montage. De verpakking bevat extra onderdelen.
- Die Mengenangaben beziehen sich auf die für die Montage nötigen Teile. Eventuell weitere beige packte Teile ignorieren.

●Outillage nécessaire ●Tools required ●Equipamiento necesario  
 ●Attrezzatura necessaria ●Benodigde gereedschap ●Werkzeuge erforderlich

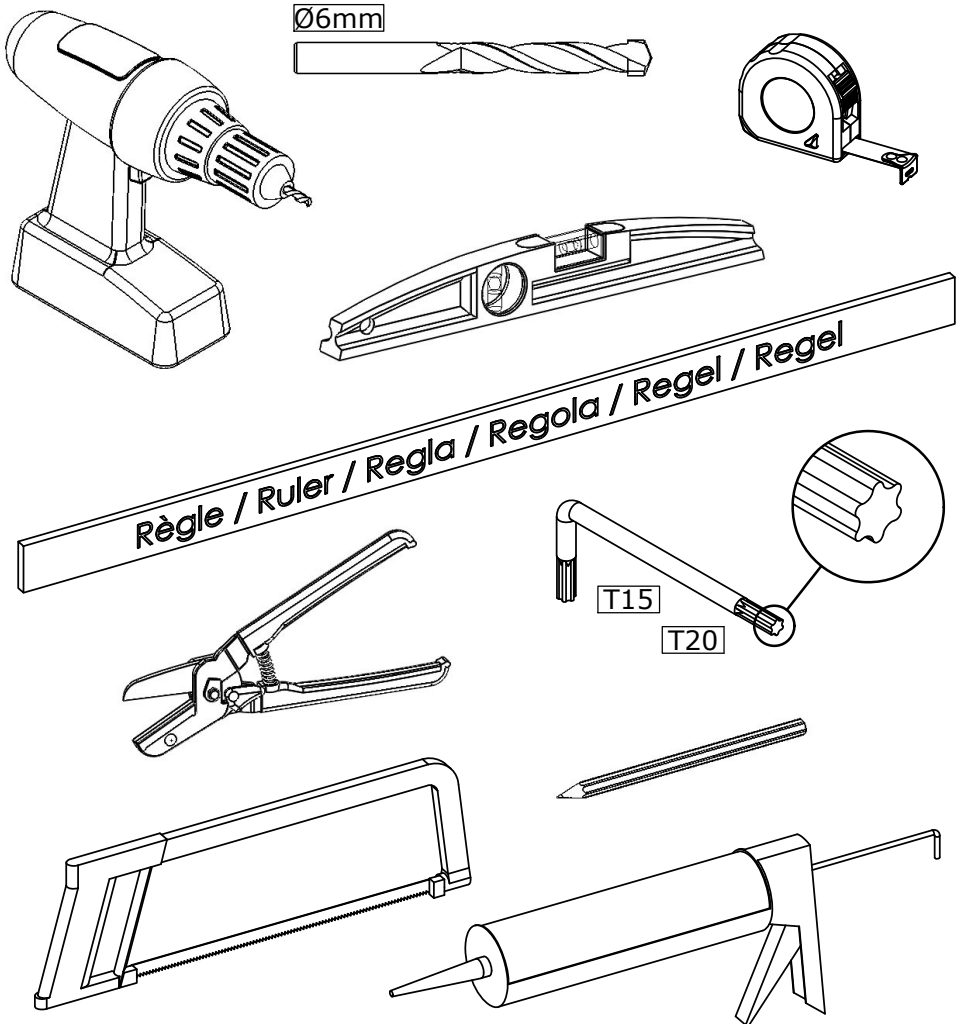

- Utiliser un silicone adapté au matériau de chaque support (faïence, acrylique, etc.)
- Use a silicone sealant that is intended for the surrounding materials (ceramic, acrylic, etc.)
- Usar una silicona adecuada para cada tipo de material (loza, acrílico, etc.)
- Utilizzare un silicone adatto a qualsiasi materiale (ceramica, acrilico, ecc.)
- Gebruik siliconenkit die geschikt is voor iedere ondergrond (tegelwerk, acryl, etc.)
- Für das jeweilige Trägermaterial (Stein, Acryl usw.) geeignetes Silikon verwenden.



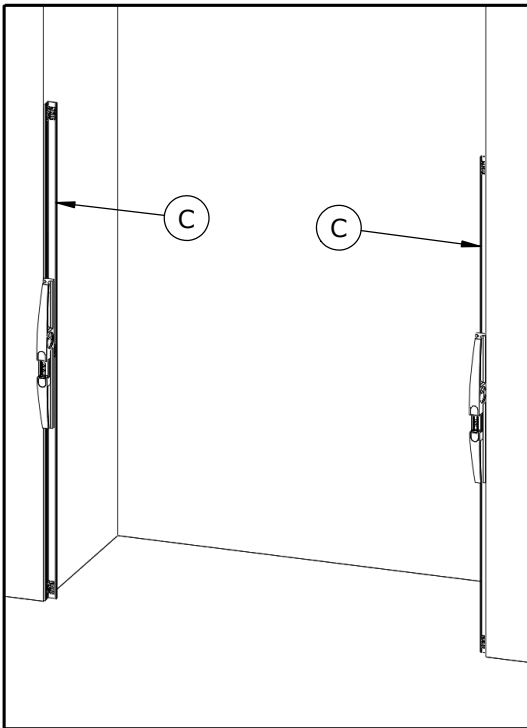

- Si receveur ● If shower tray
- Si plato ● Se piatto
- Als douchebak
- Wenn Duschwanne

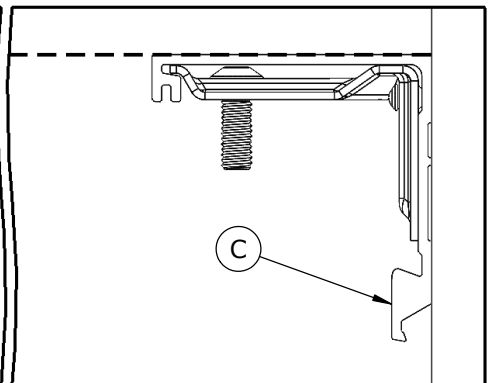
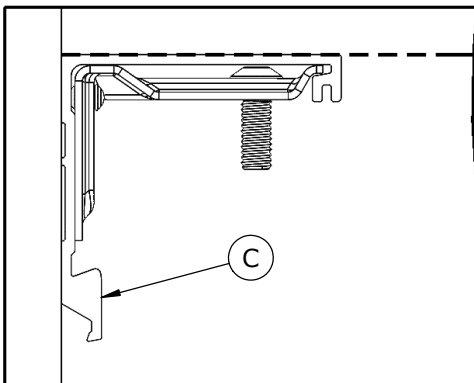
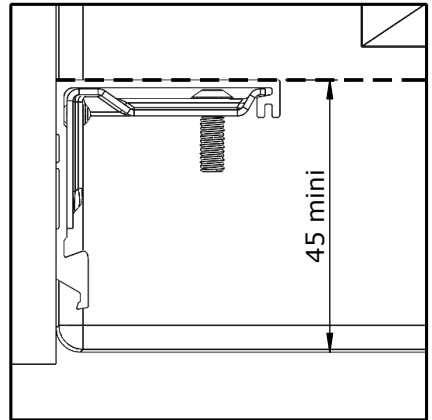

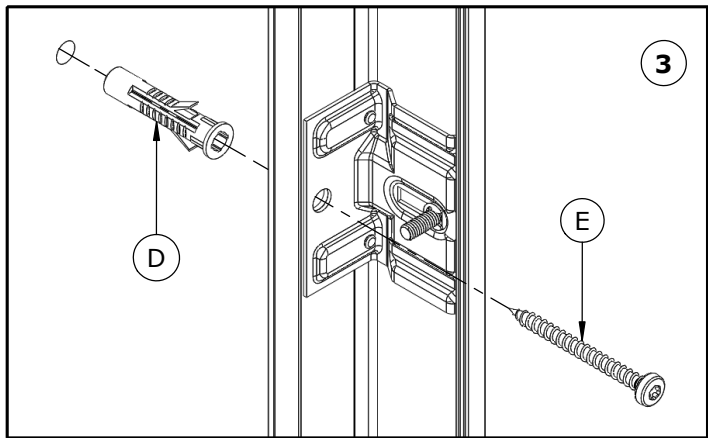
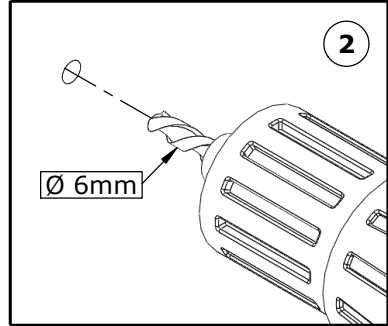
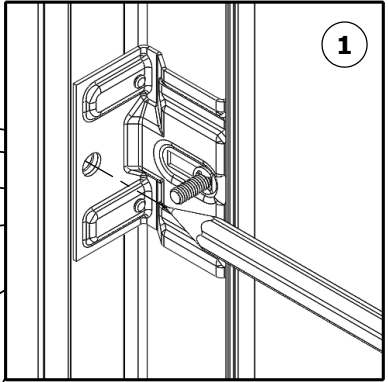
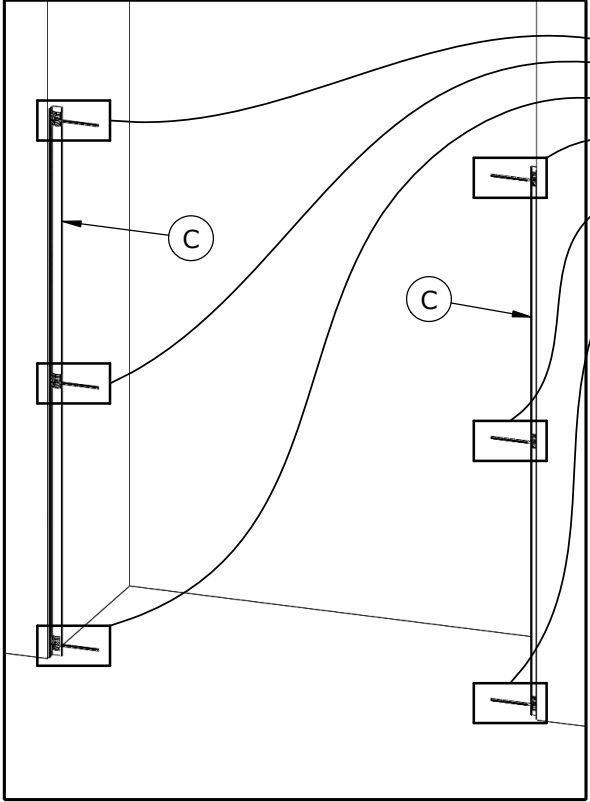

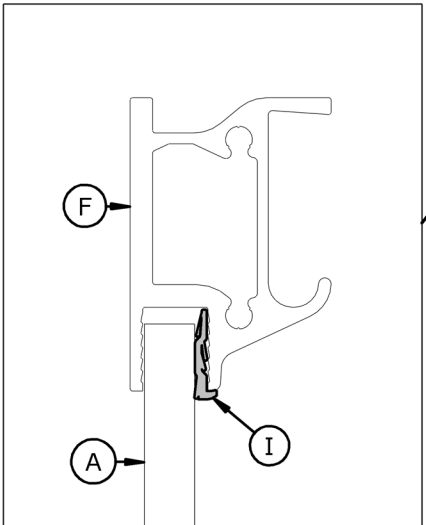
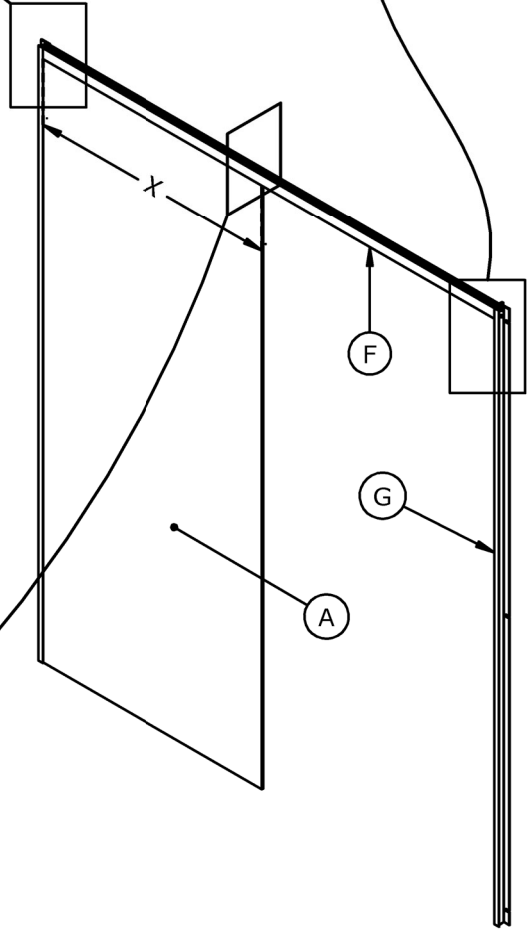
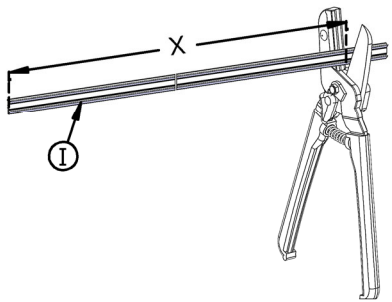
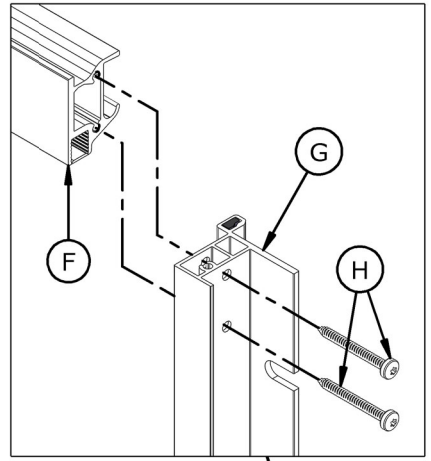
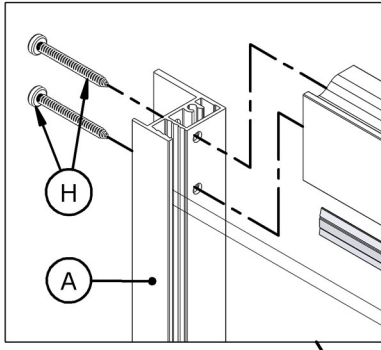



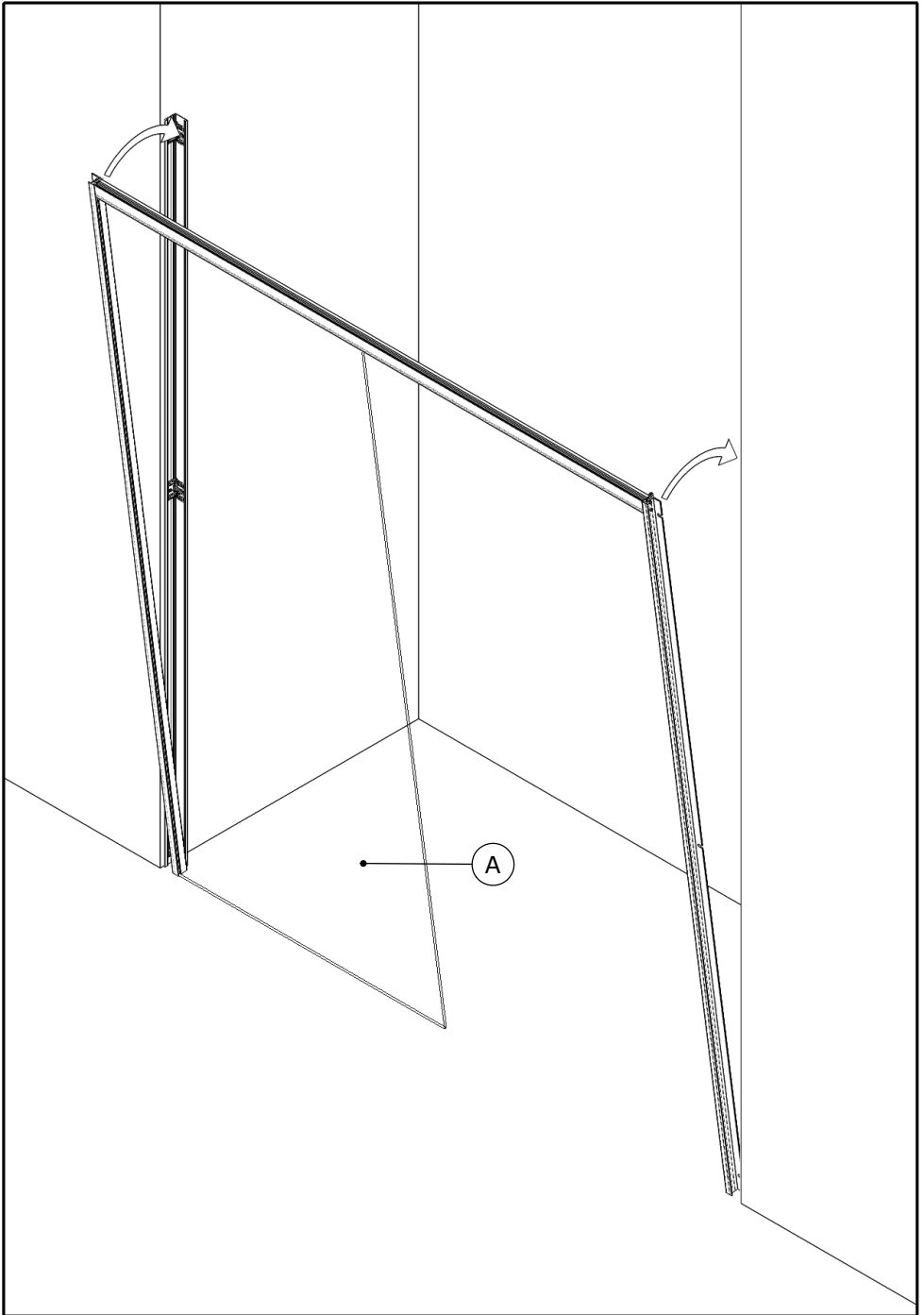

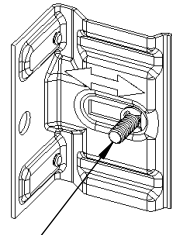
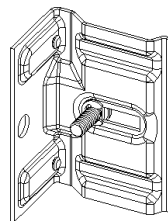
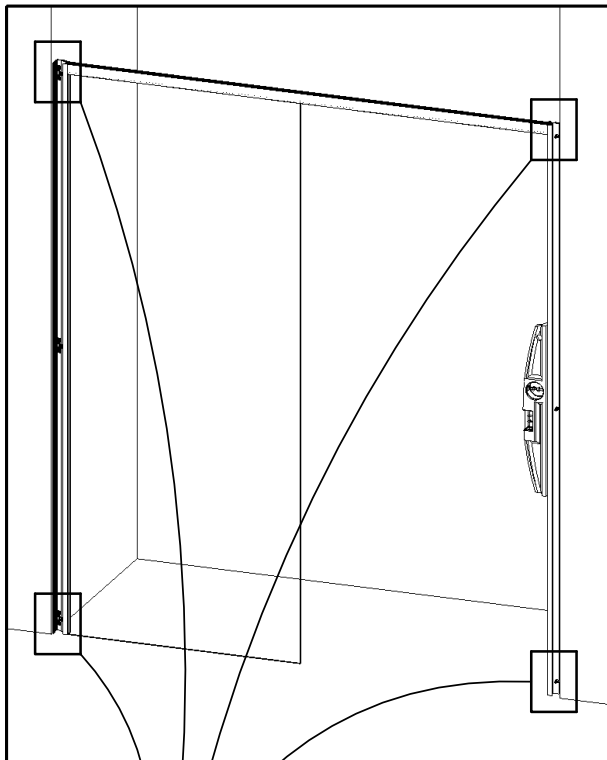

- Si nécessaire, desserrer, régler puis resserrer
- If necessary, loosen, adjust and retighten
- Si es necesario, afloje, ajuste y apriete
- Se necesario, allentare, regolare e stringere
- Draai los, indien nodig, stel af en draai vervolgens weer vast
- Falls erforderlich, lösen, einstellen und wieder festziehen

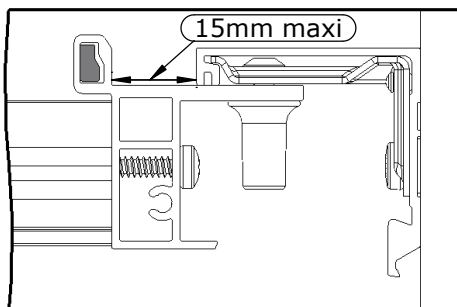
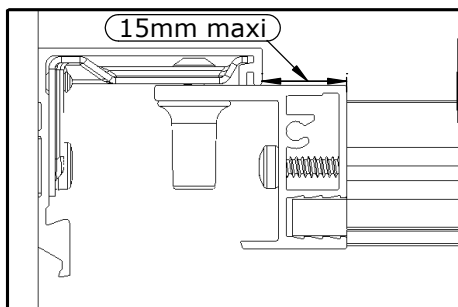
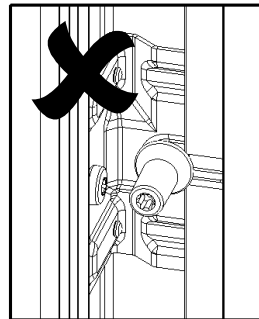
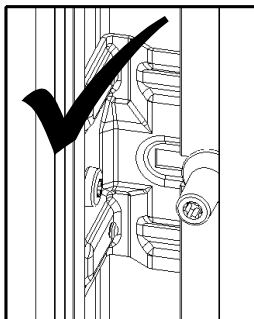
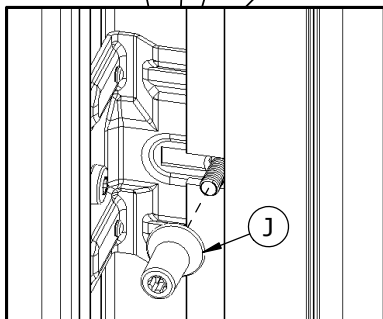

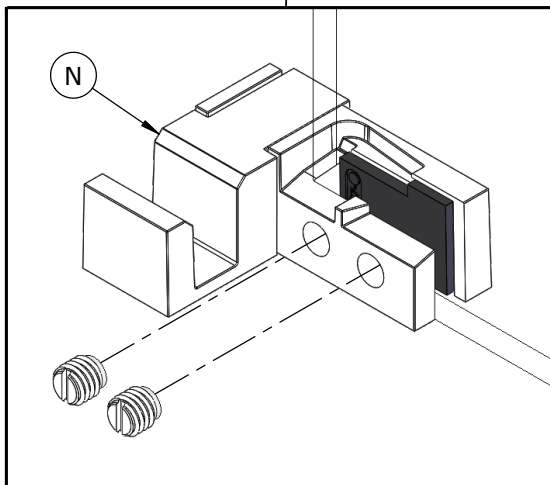
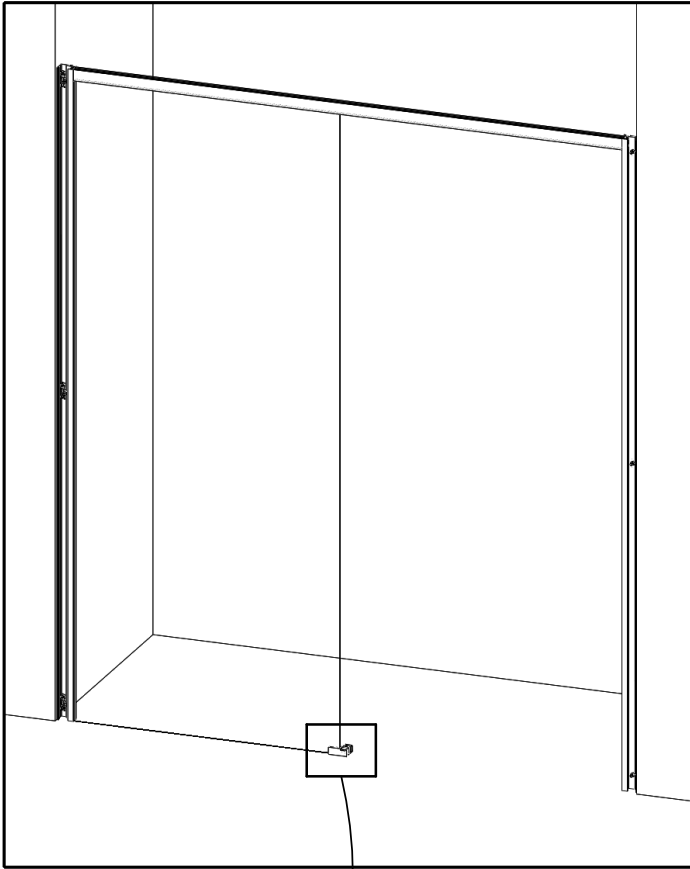

● F Vue intérieur ● B Interior view ● E Vista interior  
 ● Vista interna ● N Binnen aanzicht ● I Innenansicht

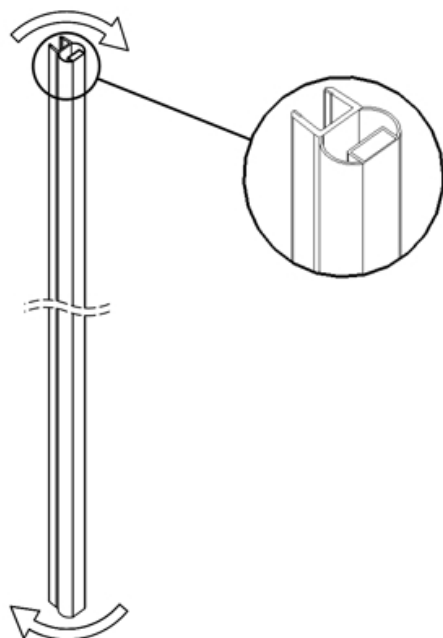
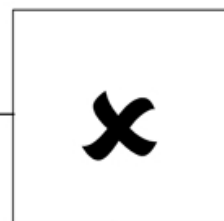
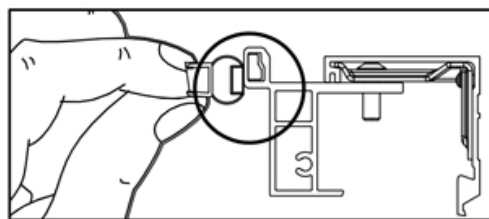
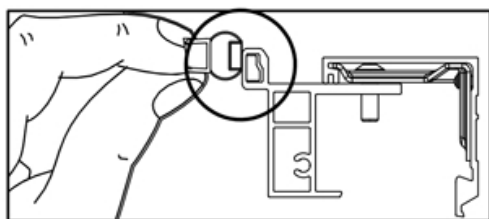
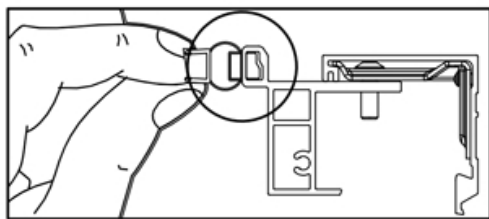

● Intérieur ● Inside  
 ● Interior ● Interno  
 ● Binnenkant ● Innen

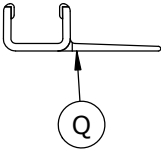

● Extérieur ● Outside  
 ● Externo ● Esterno  
 ● Buitenkant ● Außen



- Couper (Q) en partie haute
- Cut (Q) at the top
- Recortar (Q) en la parte superior
- Tagliare (Q) in alto
- Snijden (Q) in het bovenste deel
- Im oberen Bereich zuschneiden (Q)

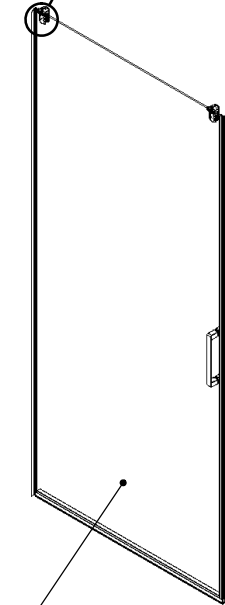
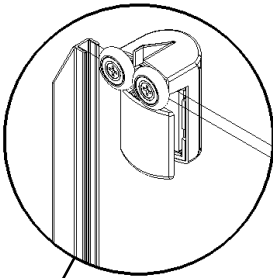

● Extérieur ● Outside  
 ● Externo ● Esterno  
 ● Buitenkant ● Außen

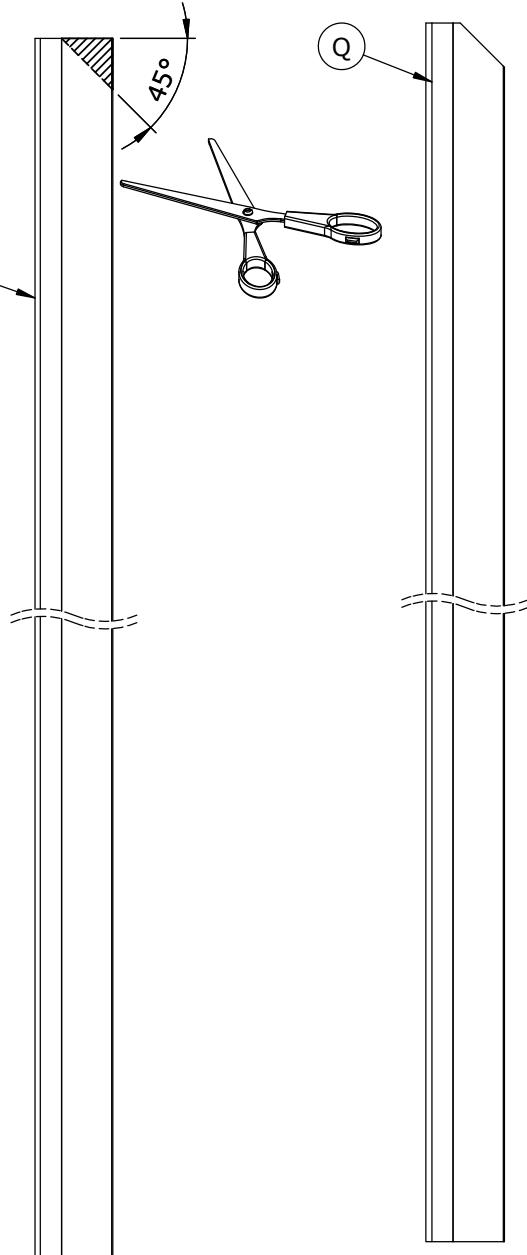

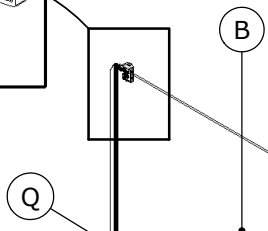
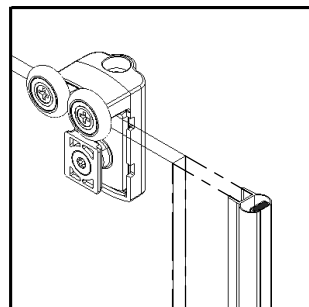
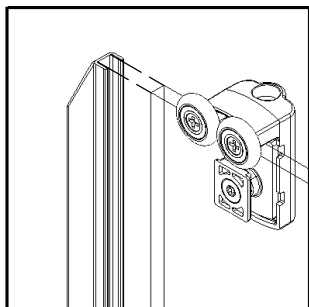

● Intérieur ● Inside  
 ● Interior ● Interno  
 ● Binnenkant ● Innen

● Extérieur ● Outside  
 ● Exterior ● Esterno  
 ● Buitenkant ● Außen

● Intérieur ● Inside  
 ● Interior ● Interno  
 ● Binnenkant ● Innen

● Extérieur ● Outside  
 ● Exterior ● Esterno  
 ● Buitenkant ● Außen

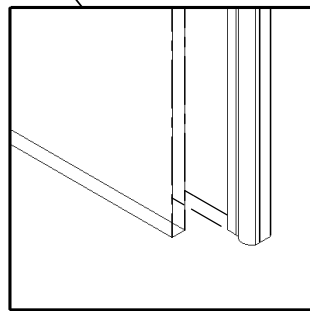
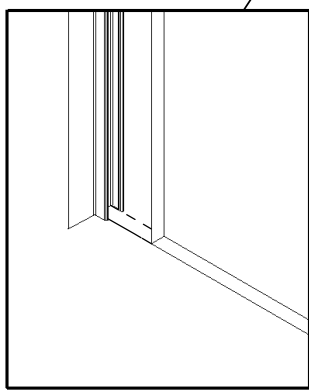

● Exterieur ● Outside ● Externo  
 ● Esterno ● Buitenkant ● Außen

● Intérieur ● Inside ● Interior  
 ● Interno ● Binnenkant ● Innen

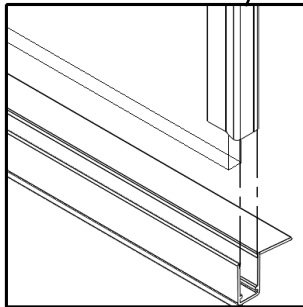
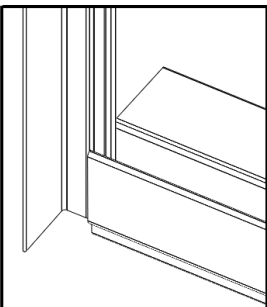
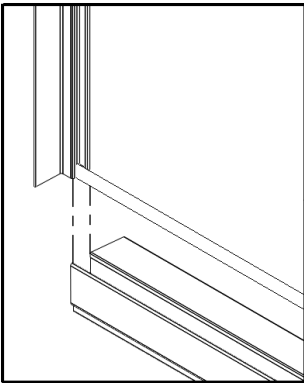
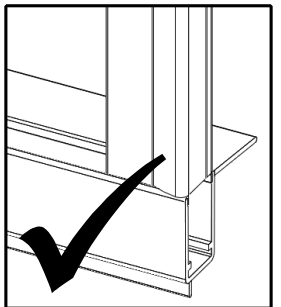
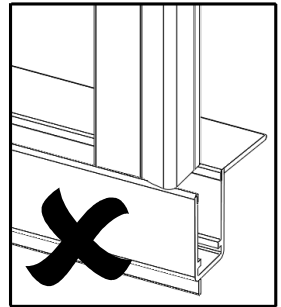
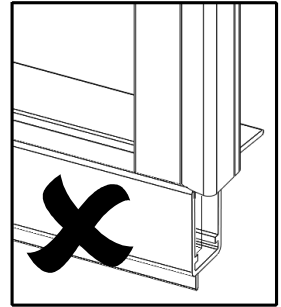
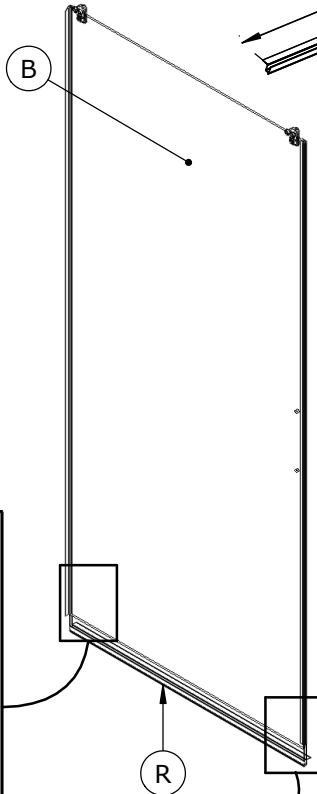
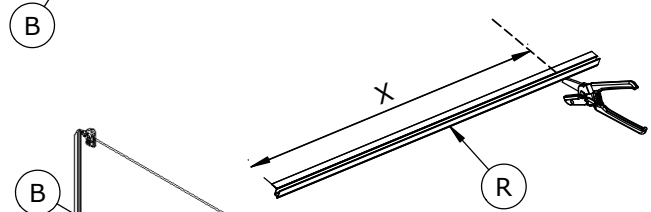
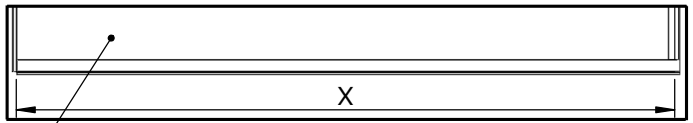

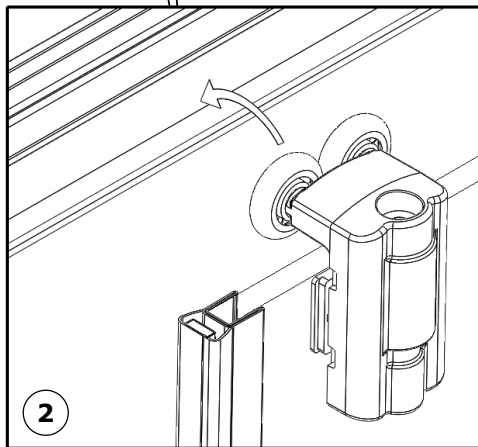
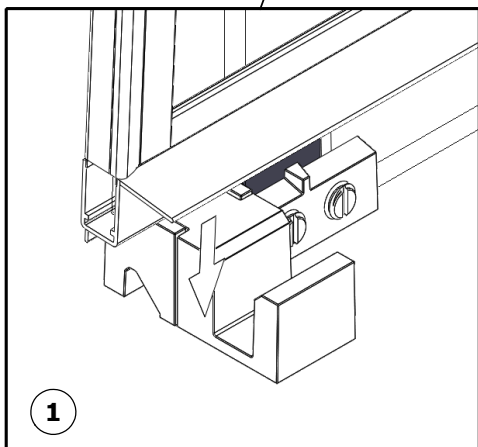
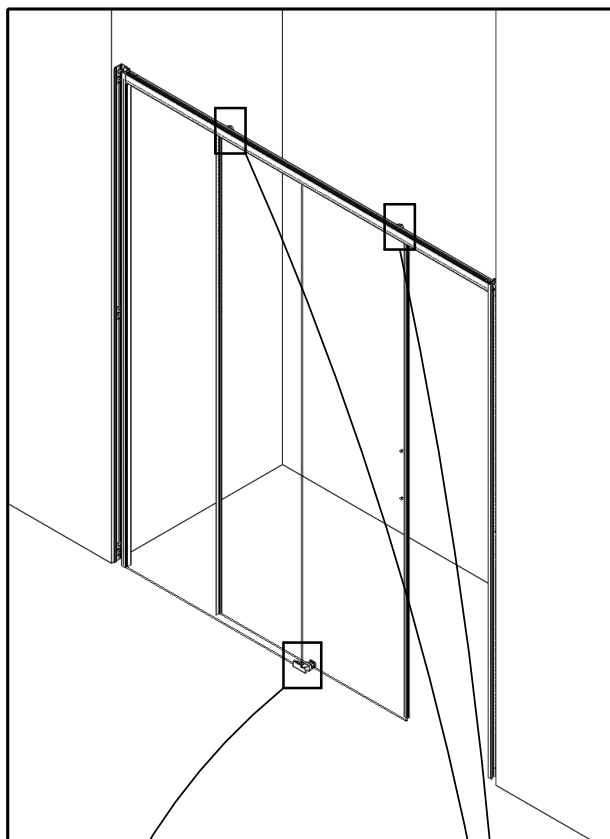



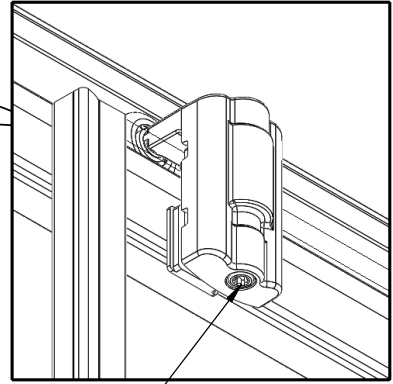
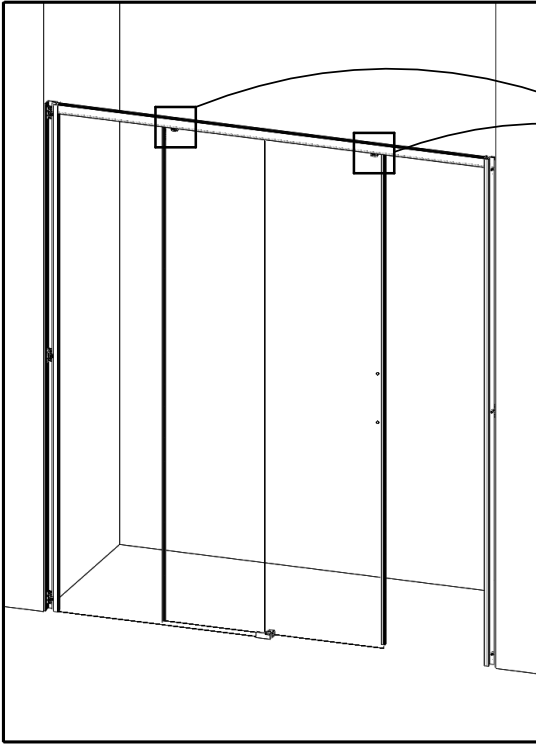

- ➊ Régler les portes afin qu'elles soient de niveau
- ➋ Adjust the doors so that they are level
- ➌ Ajustar las puertas de manera que estén niveladas
- ➍ Regolare le porte in modo che siano in bolla
- ➎ Stel de deuren zodanig af zodat ze waterpas staan
- ➏ Türen waagrecht ausrichten

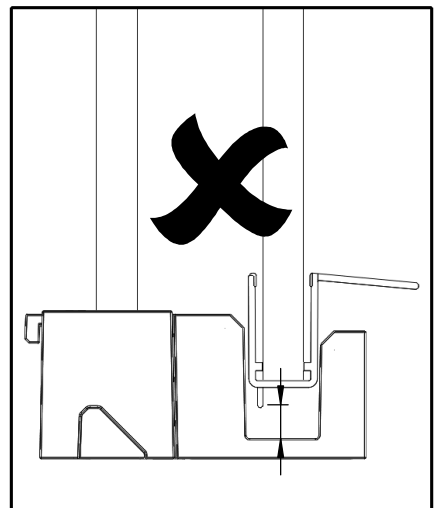
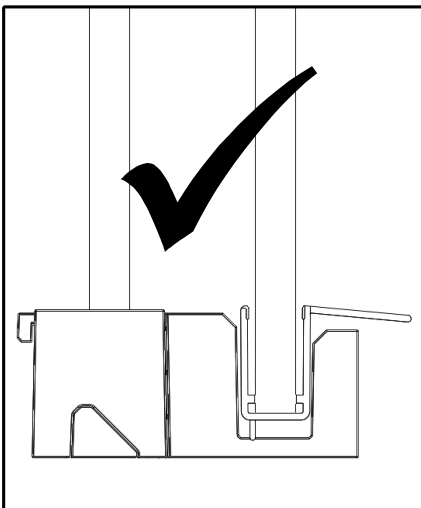

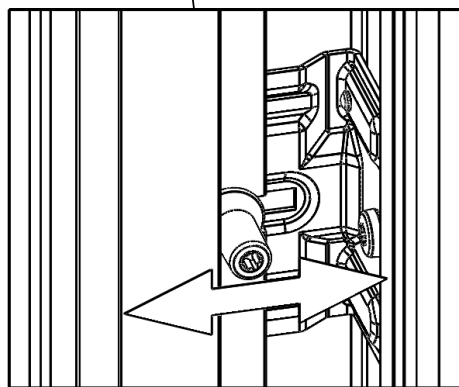
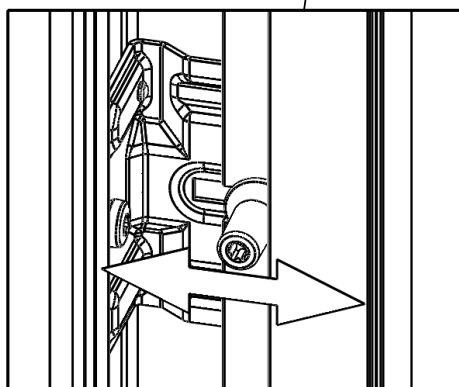
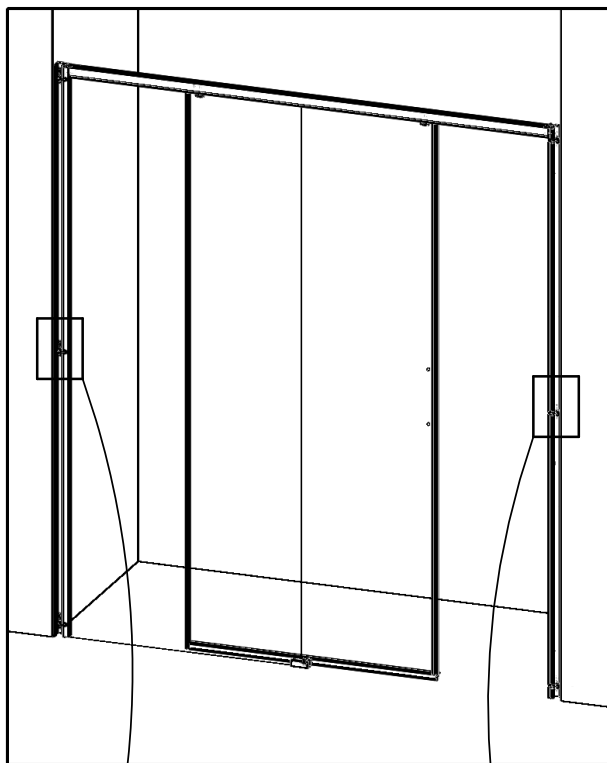

- Si nécessaire, desserrer, régler puis resserrer
- If necessary, loosen, adjust and retighten
- Si es necesario, afloje, ajuste y apriete
- Se necessario, allentare, regolare e stringere
- Draai los, indien nodig, stel af en draai vervolgens weer vast
- Falls erforderlich, lösen, einstellen und wieder festziehen

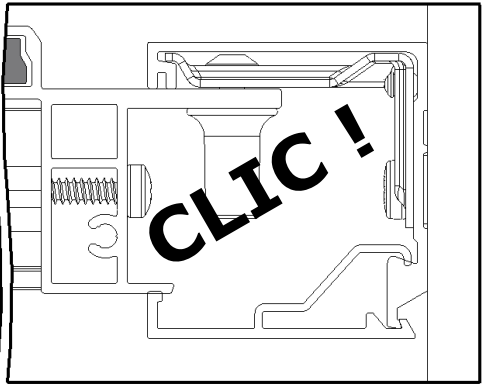
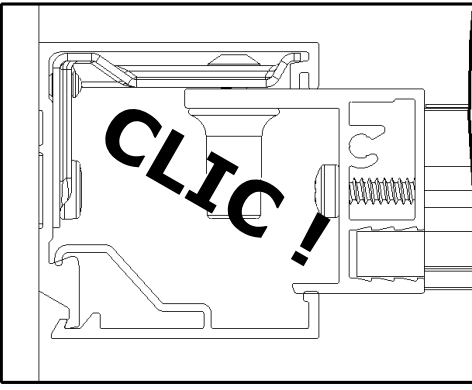
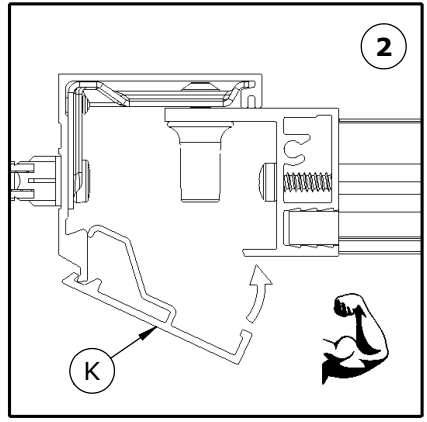
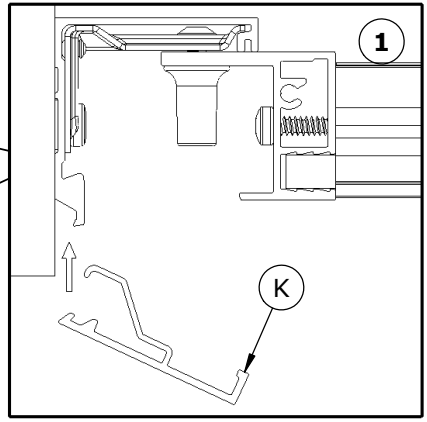
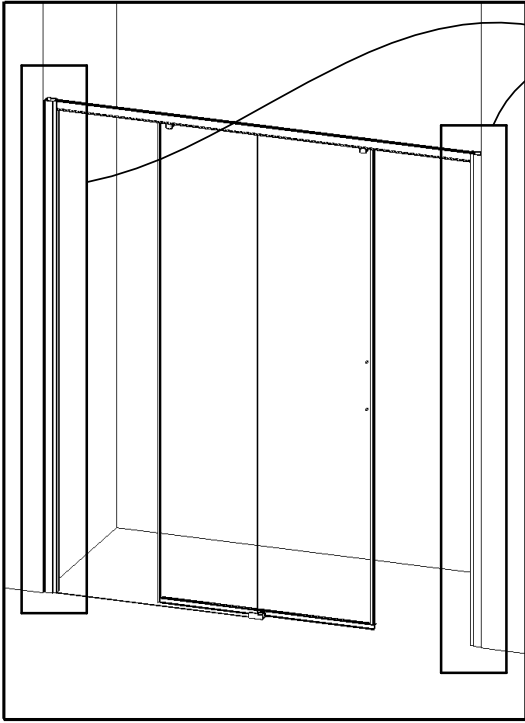

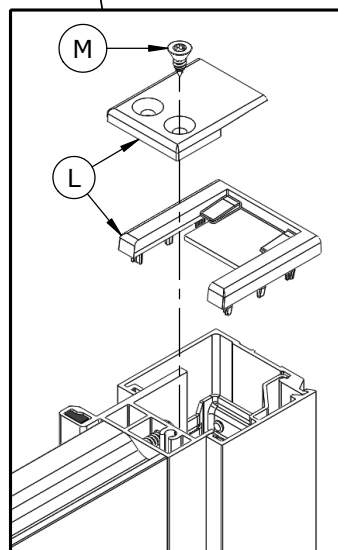
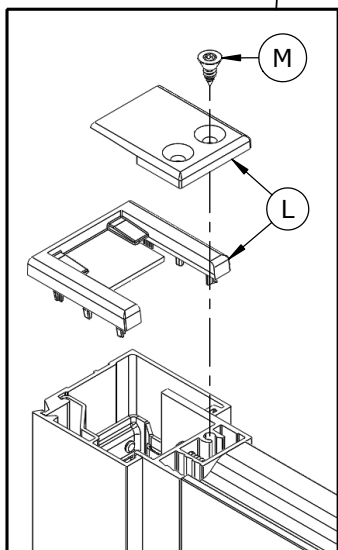
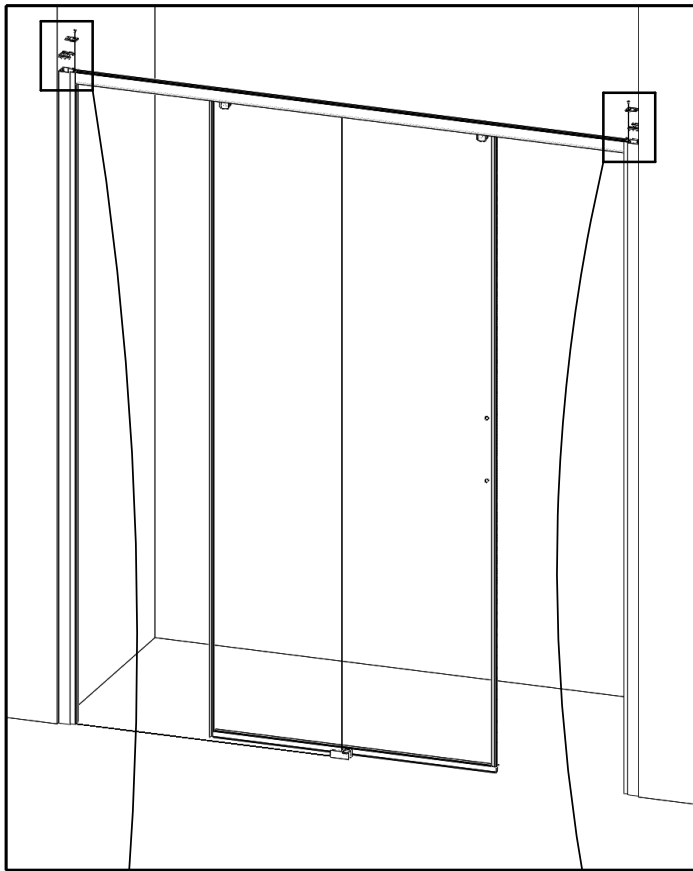

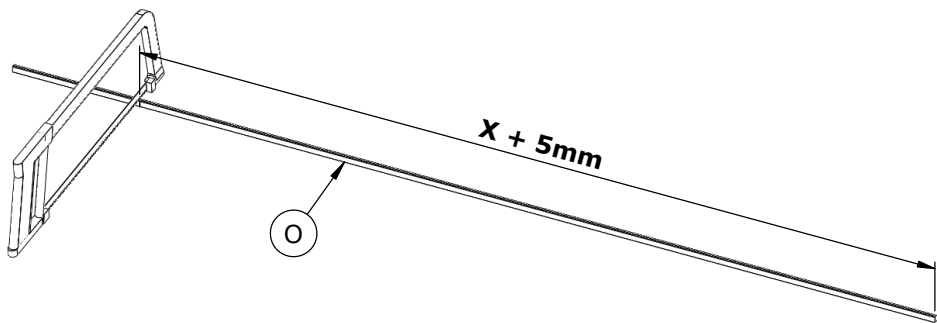
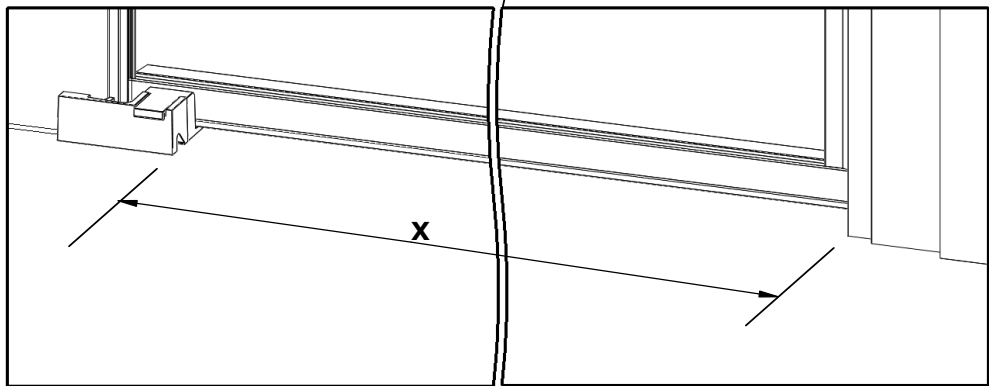
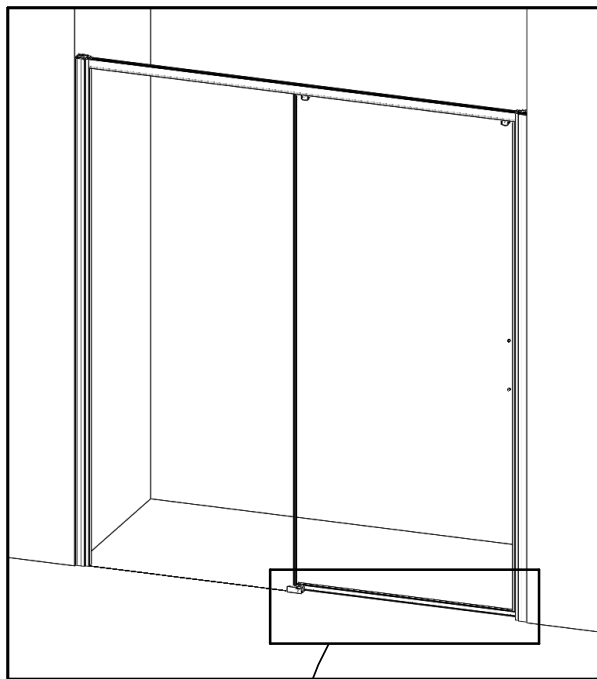

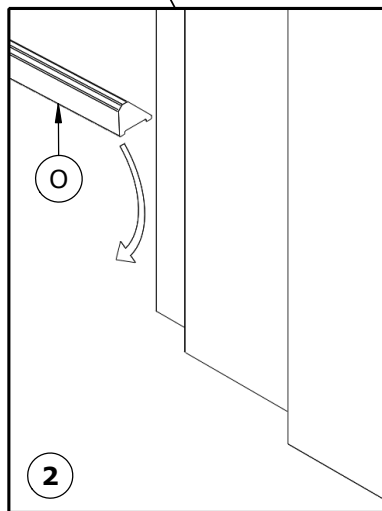
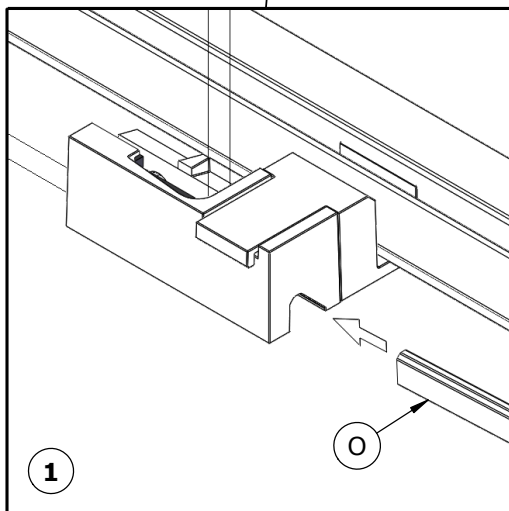
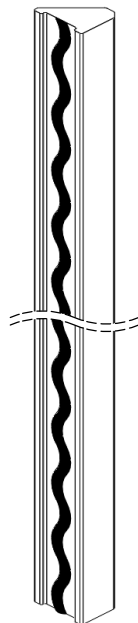
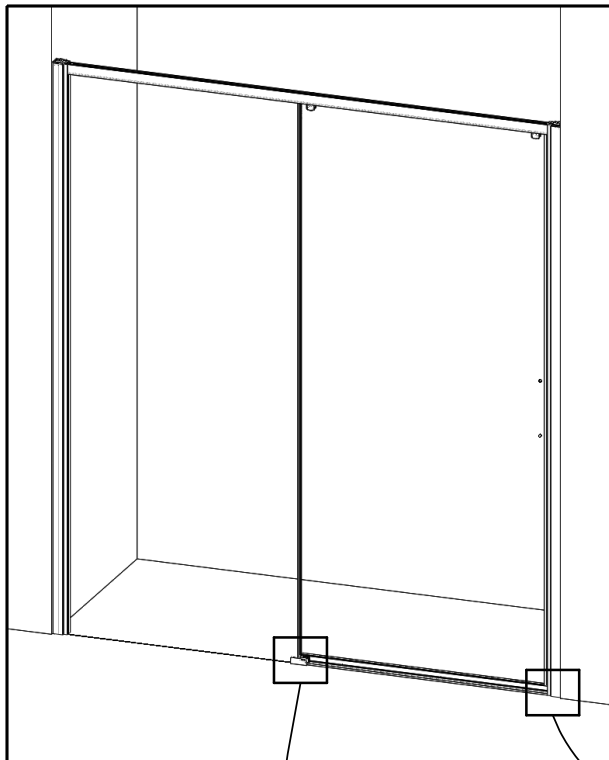

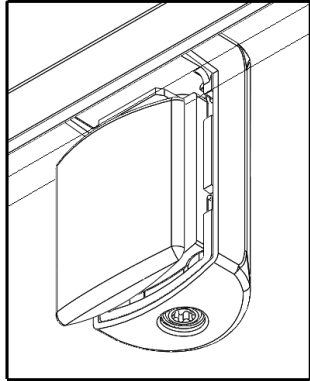
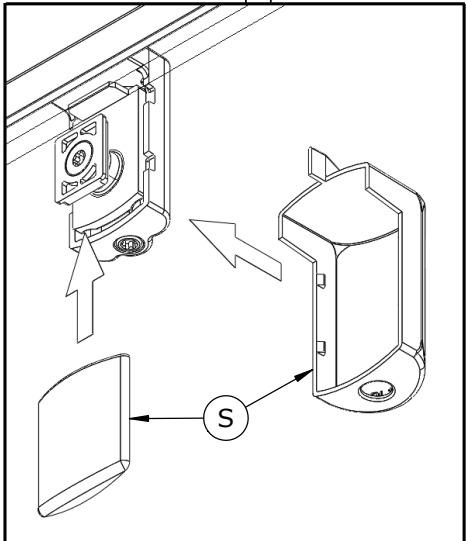
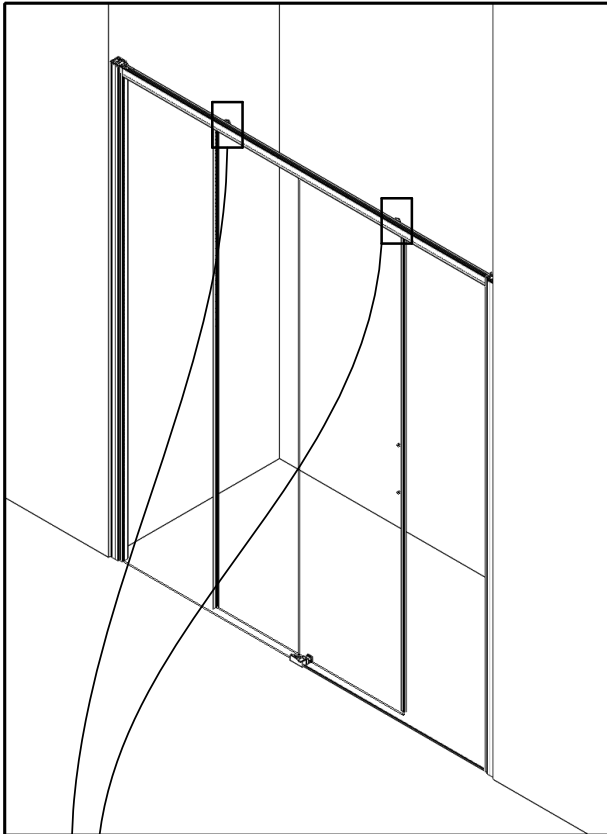

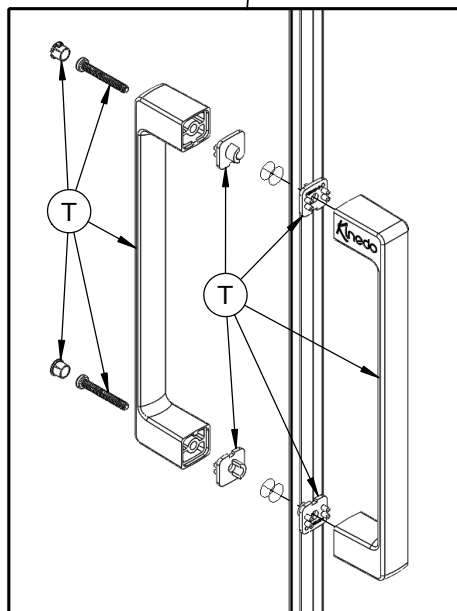
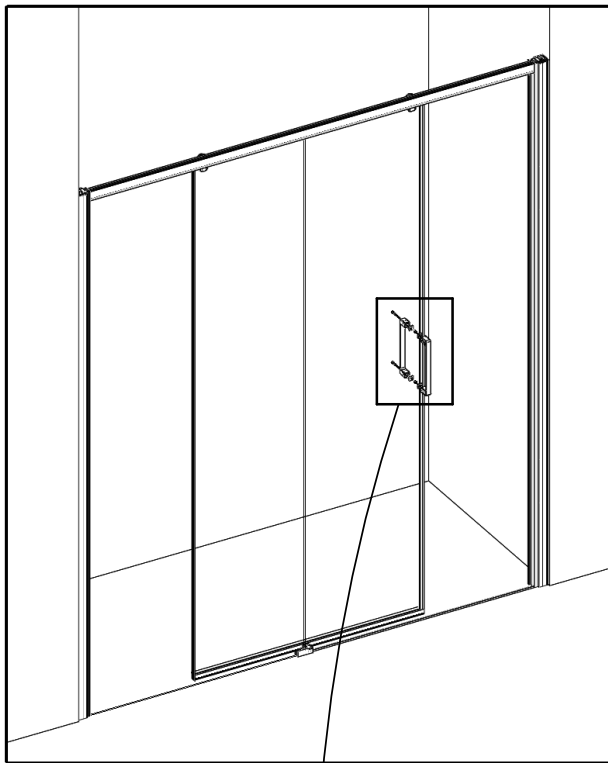



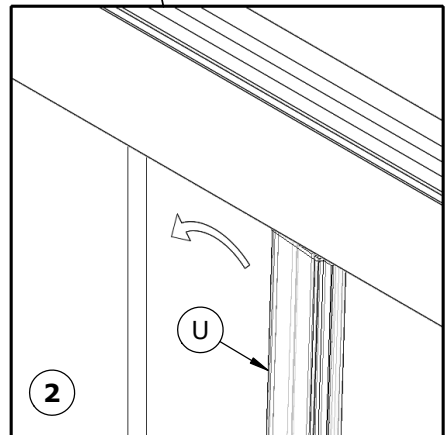
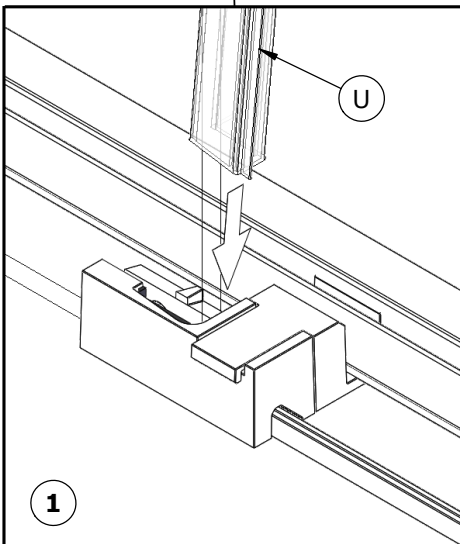
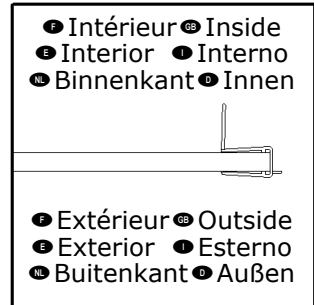
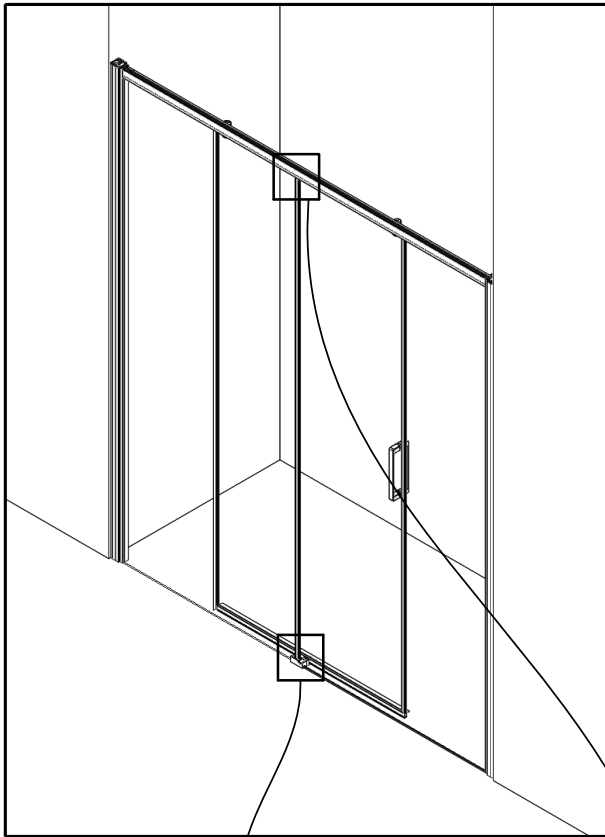

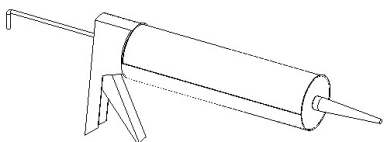

24H

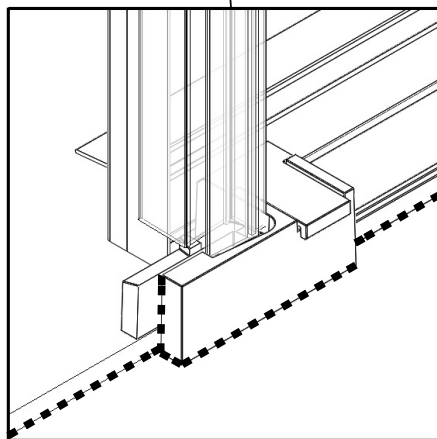
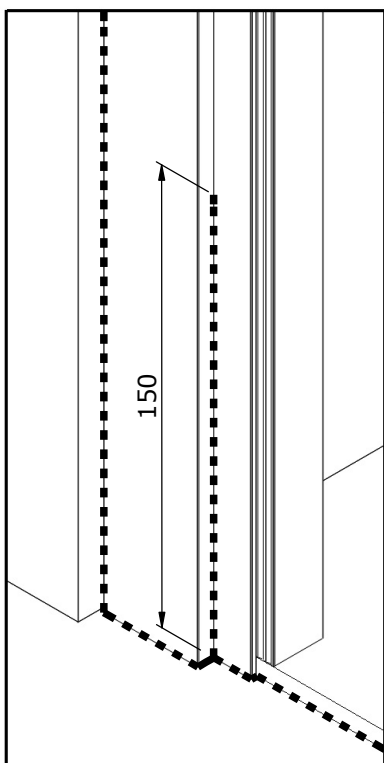
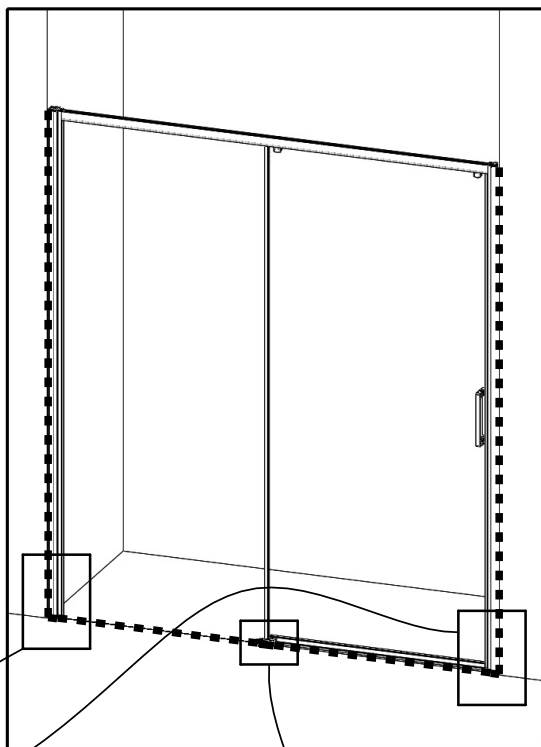



**NOTICE D'ENTRETIEN  
MAINTENANCE INSTRUCTIONS  
ISTRUZIONI DI MANUTENZIONE  
INSTRUCCIONES DE MANTENIMIENTO  
ONDERHOUDSINSTRUCTIE  
WARTUNGSANLEITUNG**



**SCAN ME**



**GARANTIE**  
**2 ANS**

**SCAN ME**





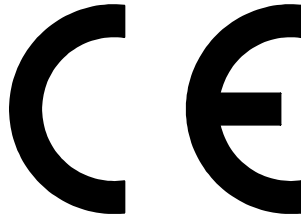

AQUAPRODUCTION, Site industriel,  
F - 44680 Chaumes-en-Retz

18

**EN 14428**

Paroi de douche, fabriquée en verre de silicate  
sodo-calcique de sécurité trempé thermiquement

Aptitude au nettoyage : réussite

Résistance à l'impact/propriétés de fragmentation : réussite

Durabilité : réussite



## SERVICE APRÈS-VENTE AFTER-SALES SERVICE

### FRANCE

+33 (0)2 40 21 29 45

### UK

+44 (0)20 8842 0033

### IRELAND

+353 04697 33102

### DEUTSCHLAND

+49 (0) 6074 / 30928 0

### ITALIA

+39 02 30559420

### ÖSTEREICH

+43 1 710 60 70

### SUISSE/SCHWEIZ

+41 (0)32 631 04 74

### ESPAÑA

+34 93 544 60 76

### NEDERLAND

+31 475 487 100

### BELGIQUE/BELGIË

+31 475 487 100

### РОССИЯ

+7 495 258-29-51

### PORTUGAL

+351 219 112 785