

- F Notice de montage ● GB Installation instructions
- E Manual de instalación ● I Istruzioni di montaggio
- NL Montage-instructies ● D Montageanleitung

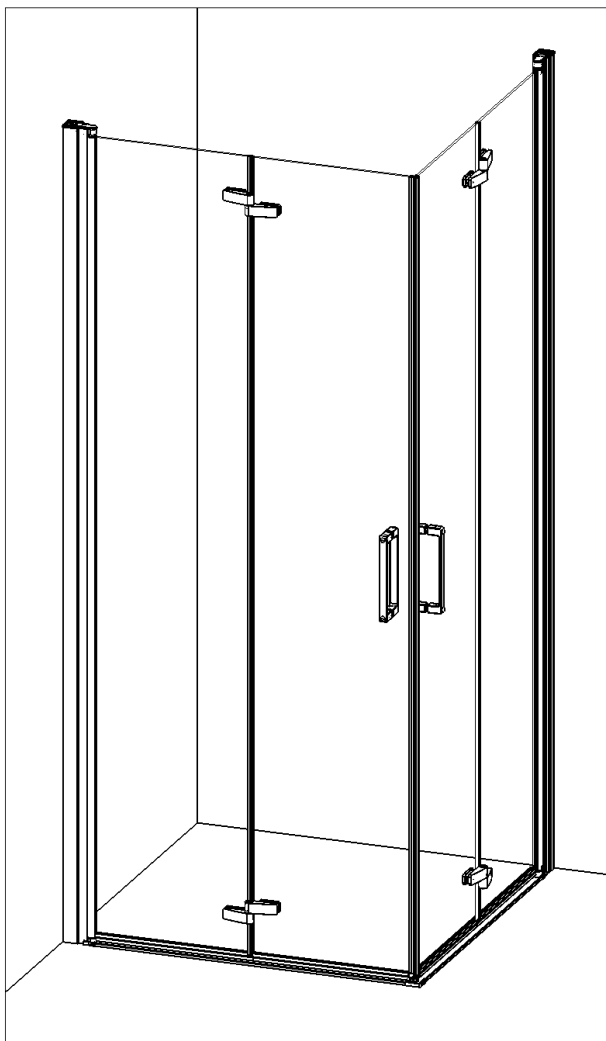



Notre service technique est  
à votre écoute aux numéros  
qui sont au dos de cette  
notice d'installation

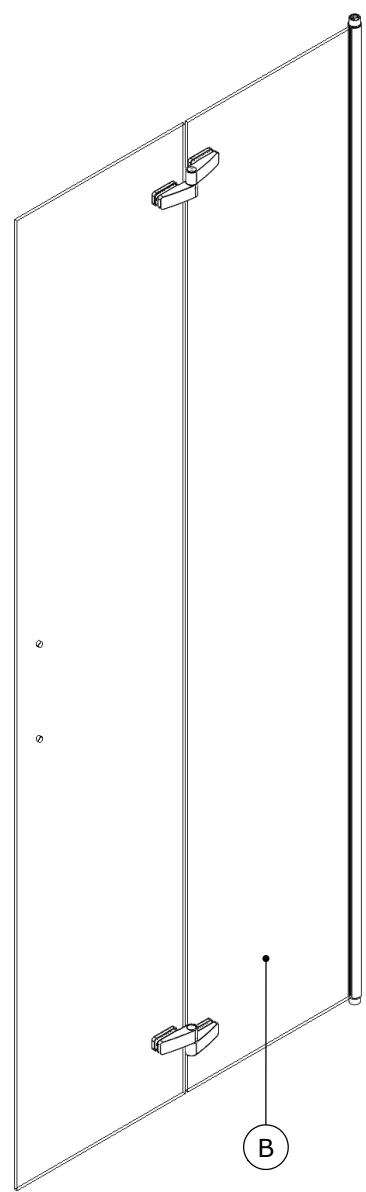
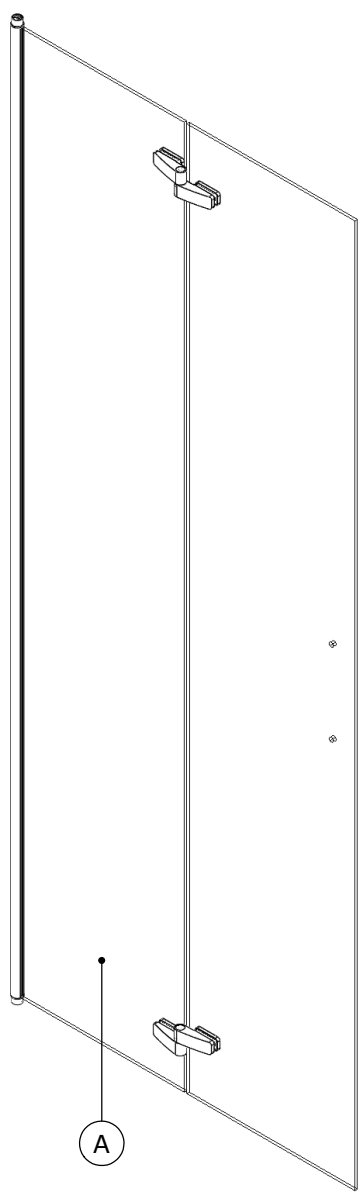

- F Attention aux étapes :
- GB Check installation steps :
- E Atención a los pasos :
- I Attenzione ai passi :
- NL Aandacht voor de stappen :
- D Achtung vor den Schritten :

P. 6 - 24 - 37

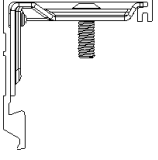
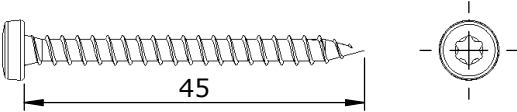
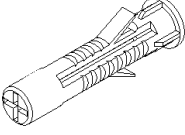
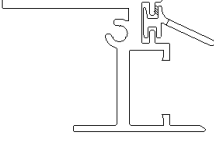
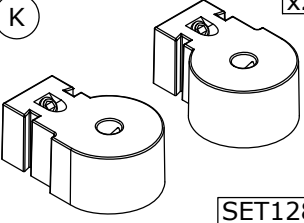
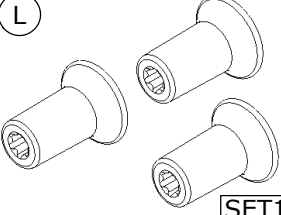
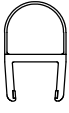
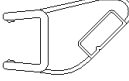
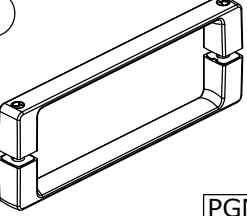
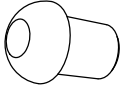
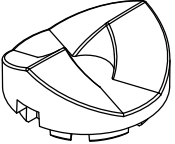
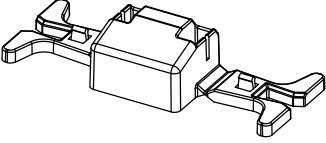

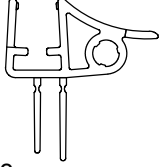
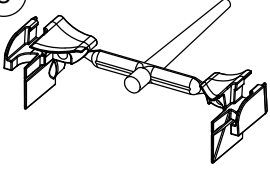
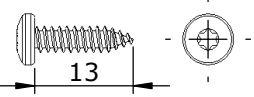
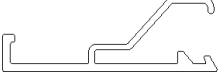
<p><b>G</b> <span style="float: right;">x2</span></p>  <p style="text-align: right;"><b>6268</b></p>	<p><b>H</b> <span style="float: right;">Ø4</span> <span style="float: right;">x6</span></p>  <p style="text-align: right;"><b>VIS231</b></p>	
<p><b>I</b> <span style="float: right;">x6</span></p>  <p style="text-align: right;"><b>CHE02</b></p>	<p><b>J</b> <span style="float: right;">x2</span></p>  <p style="text-align: right;"><b>6272</b></p>	<p><b>K</b> <span style="float: right;">x2</span></p>  <p style="text-align: right;"><b>SET128</b></p>
<p><b>L</b> <span style="float: right;">x2</span></p>  <p style="text-align: right;"><b>SET134</b></p>	<p><b>M</b> <span style="float: right;">x2</span></p>  <p>Lg=1962mm <span style="float: right;"><b>J808</b></span></p>	<p><b>N</b> <span style="float: right;">x1</span></p>  <p>Lg=1962mm <span style="float: right;"><b>AI175</b></span></p>
<p><b>O</b> <span style="float: right;">x2</span></p>  <p style="text-align: right;"><b>PGN49</b></p>	<p><b>P</b> <span style="float: right;">x4</span></p>  <p style="text-align: right;"><b>BUT44</b></p>	<p><b>Q</b> <span style="float: right;">x2</span></p>  <p style="text-align: right;"><b>PPL1248</b></p>
<p><b>R</b> <span style="float: right;">x4</span></p>  <p style="text-align: right;"><b>PPL1339</b></p>	<p><b>S</b> <span style="float: right;">x1</span></p>  <p>Lg=1962mm <span style="float: right;"><b>AI176</b></span></p>	<p><b>T</b> <span style="float: right;">x4</span></p>  <p>Lg=1100mm <span style="float: right;"><b>J806</b></span></p>
<p><b>U</b> <span style="float: right;">x1</span></p>  <p style="text-align: right;"><b>SET143</b></p>	<p><b>V</b> <span style="float: right;">Ø3.5</span> <span style="float: right;">x2</span></p>  <p style="text-align: right;"><b>VIS217</b></p>	<p><b>W</b> <span style="float: right;">x2</span></p>  <p style="text-align: right;"><b>6270</b></p>

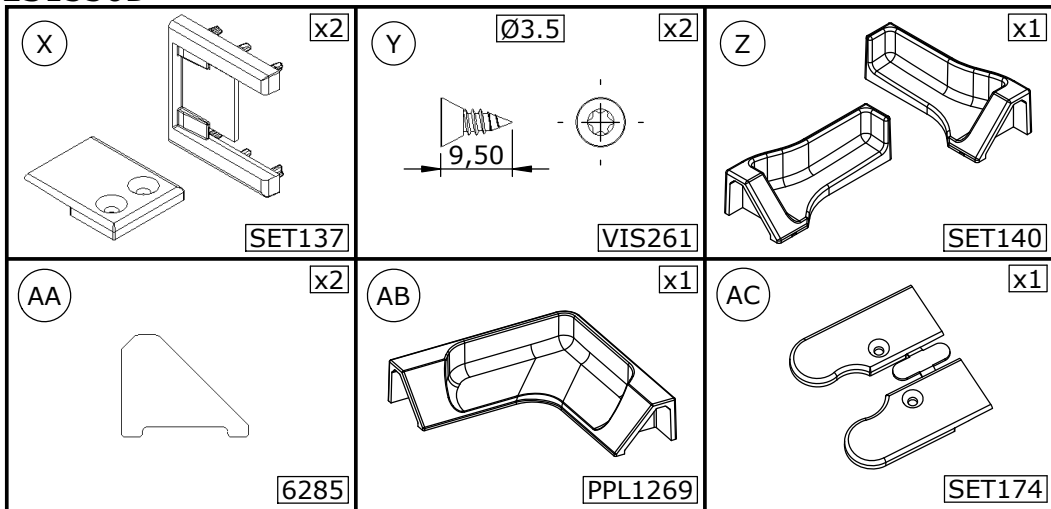

- Les quantités données sont les quantités utiles au montage. les sachets fournis contiennent des pièces supplémentaires.
  - The quantities given are what are required for the installation. There may be some surplus in the package provide.
- Las cantidades indicadas son las cantidades necesarias para el montaje. Las bolsitas incluidas contienen piezas suplementarias.
  - Le quantità fornite sono le quantità necessarie al montaggio. I sacchetti forniti contengono pezzi supplementari.
  - De aangegeven aantallen zijn vereist voor de montage. De verpakking bevat extra onderdelen.
- Die Mengenangaben beziehen sich auf die für die Montage nötigen Teile. Eventuell weitere beige packte Teile ignorieren.

●Outillage nécessaire ●Tools required ●Equipamiento necesario  
 ●Attrezzatura necessaria ●Benodigde gereedschap ●Werkzeuge erforderlich

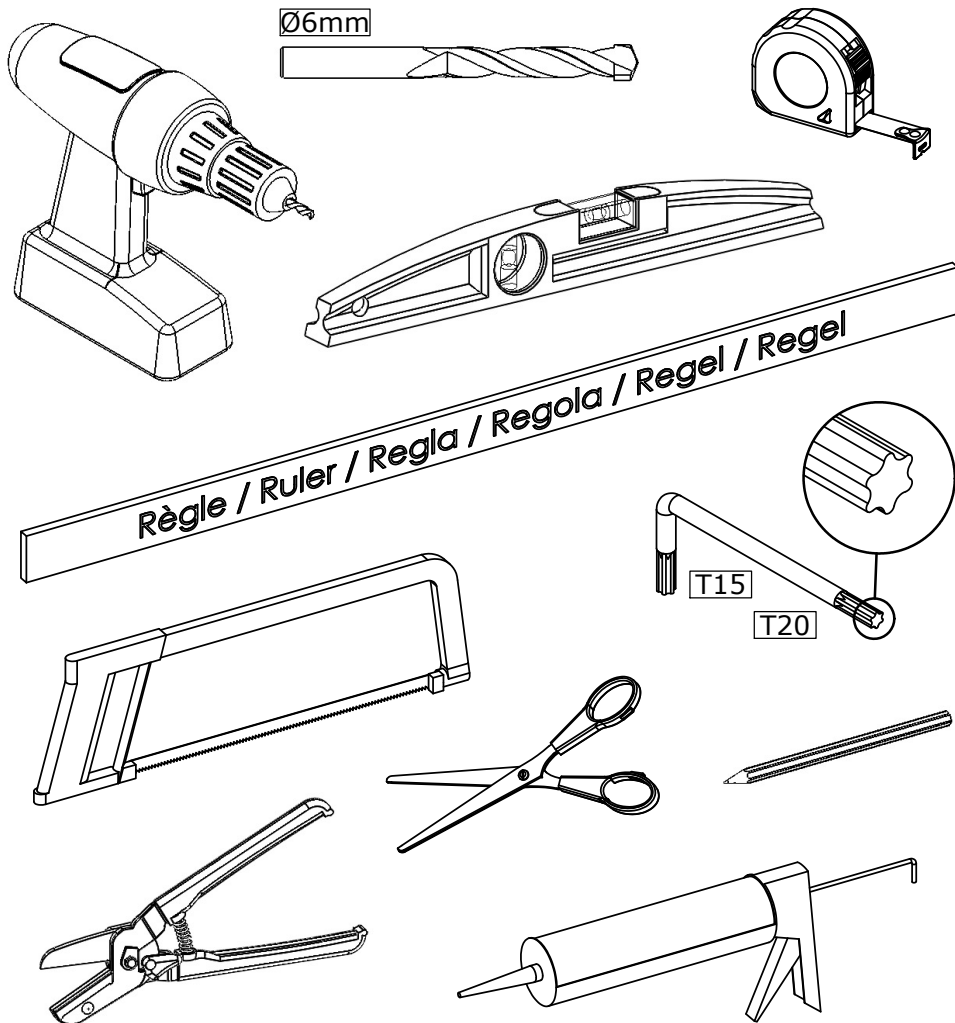

- Utiliser un silicone adapté au matériau de chaque support (faïence, acrylique, etc.)
- Use a silicone sealant that is intended for the surrounding materials (ceramic, acrylic, etc.)
- Usar una silicona adecuada para cada tipo de material (loza, acrílico, etc.)
- Utilizzare un silicone adatto a qualsiasi materiale (ceramica, acrilico, ecc.)
- Gebruik siliconenkit die geschikt is voor iedere ondergrond (tegelwerk, acryl, etc.)
- Für das jeweilige Trägermaterial (Stein, Acryl usw.) geeignetes Silikon verwenden.



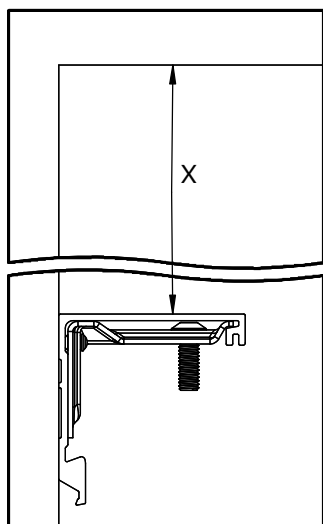
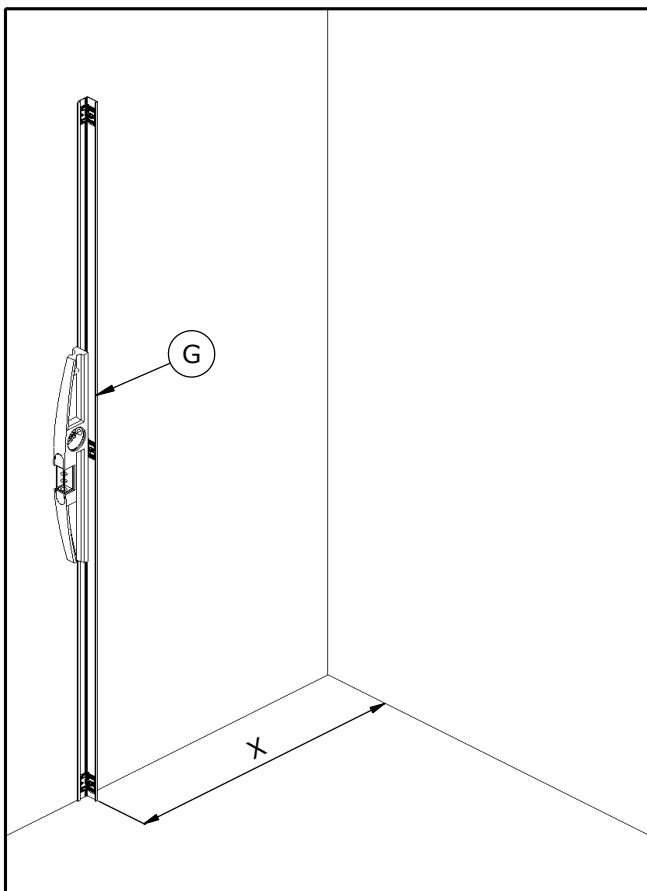

DIMENSIONS (cm)	X (mm)
70	630 - 645
75	680 - 685
80	730 - 745
85	780 - 785
90	830 - 845
95	880 - 885
100	930 - 945

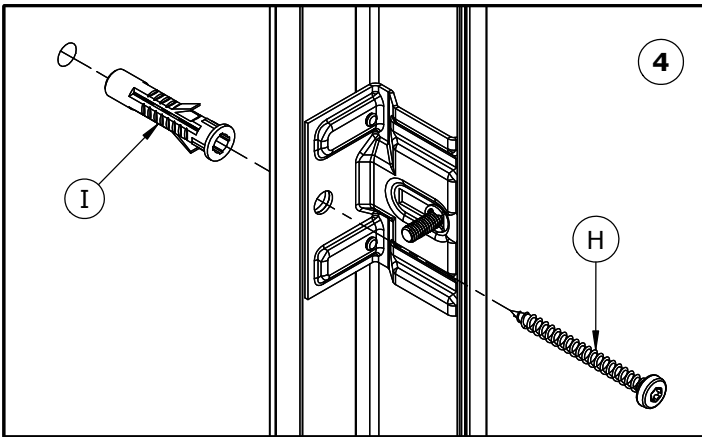
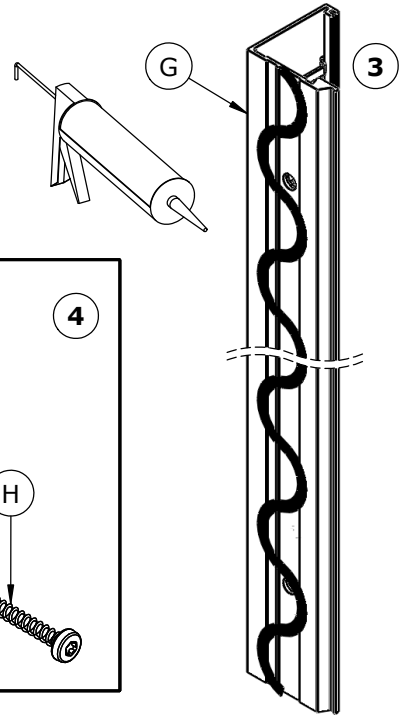
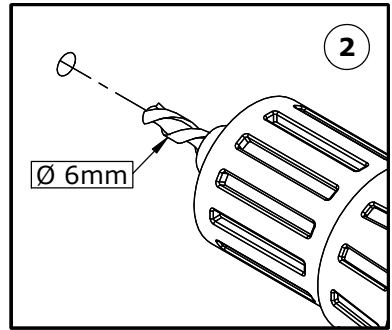
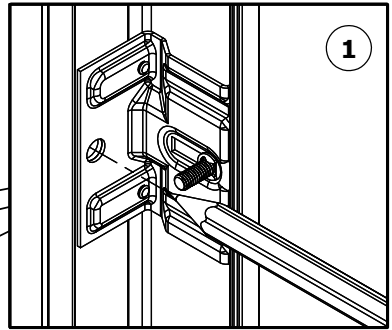
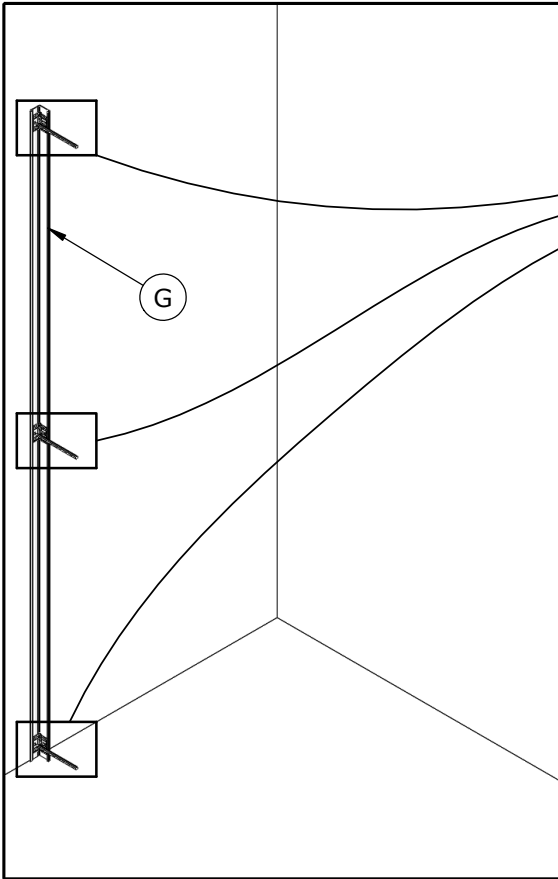

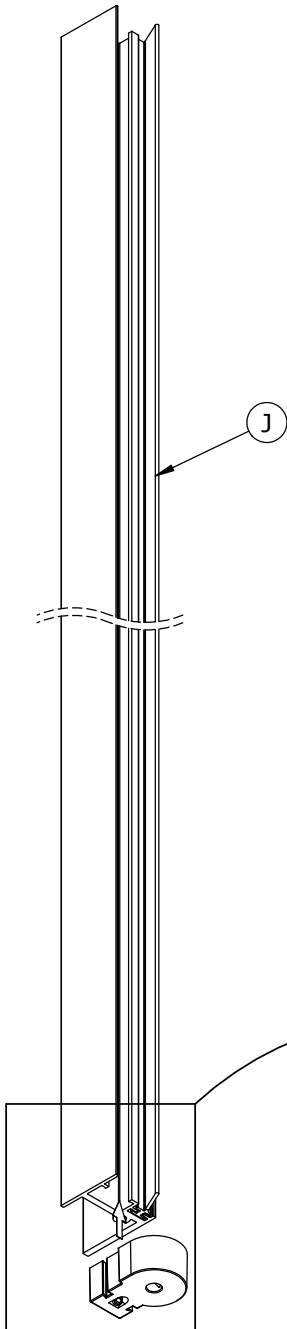

- Affleurant ● Flush
- Afloramiento ● Affioramento
- Doorspoelen ● Bündig

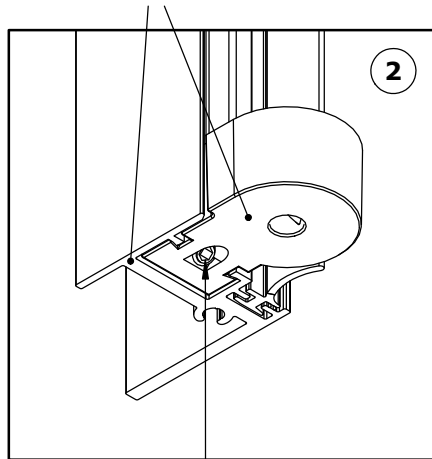

- Serrer fort ● Tighten hard
- Apretar fuerte ● Serrare forte
- Draai stevig vast ● Fest anziehen

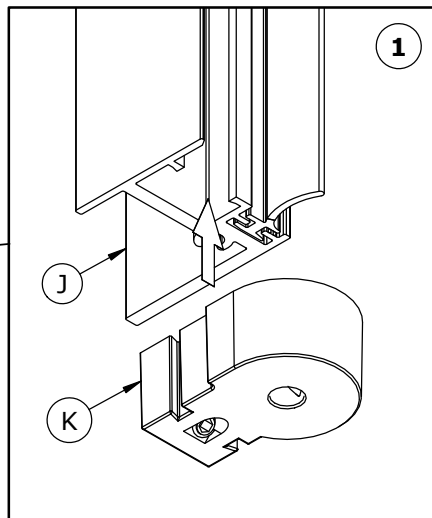



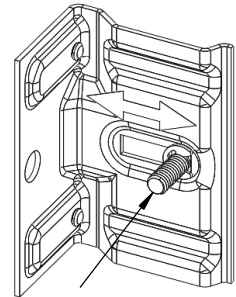
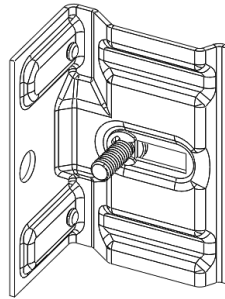

- Si nécessaire, desserrer, régler puis resserrer
- If necessary, loosen, adjust and retighten
- Si es necesario, afloje, ajuste y apriete
- Se necessario, allentare, regolare e stringere
- Draai los, indien nodig, stel af en draai vervolgens weer vast
- Falls erforderlich, lösen, einstellen und wieder festziehen

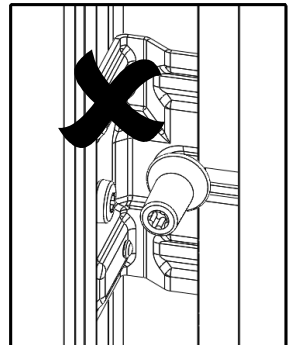
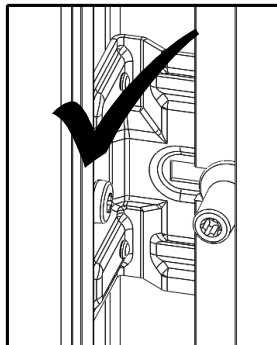
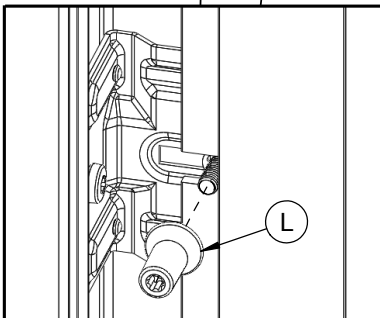

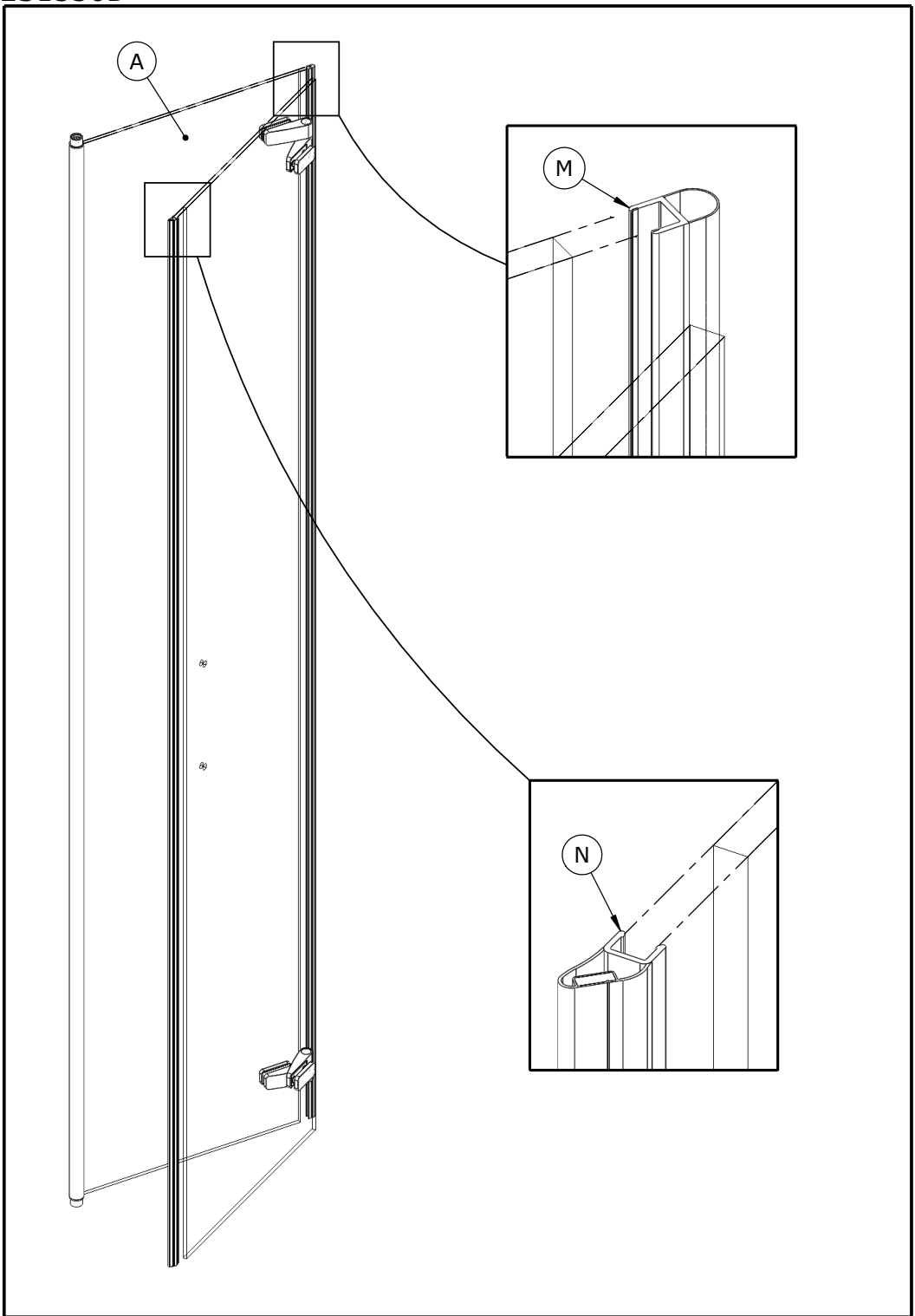

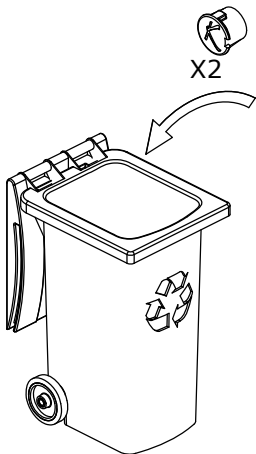
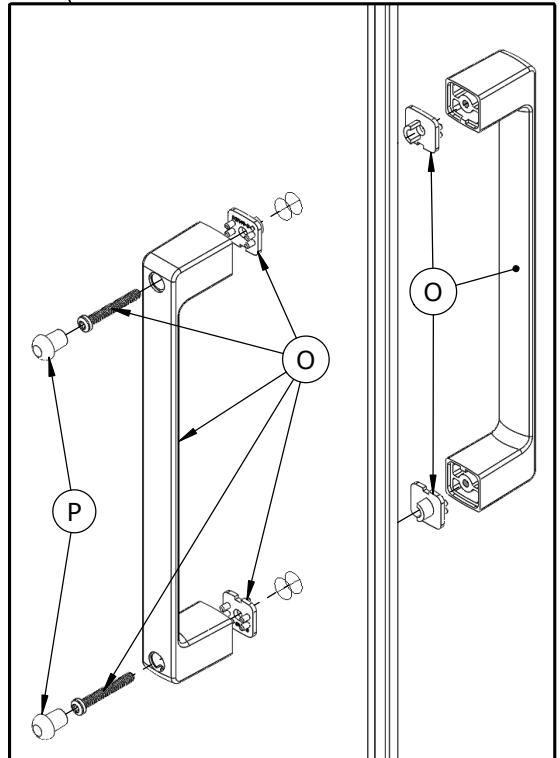
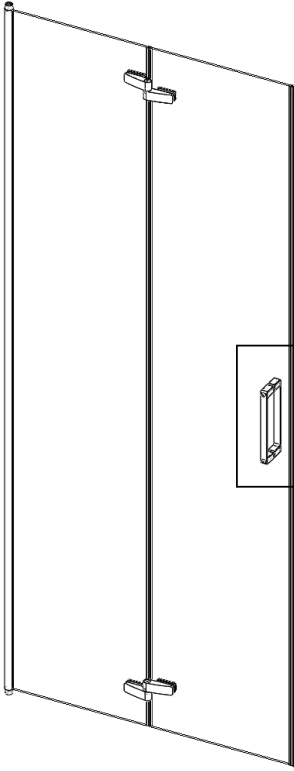

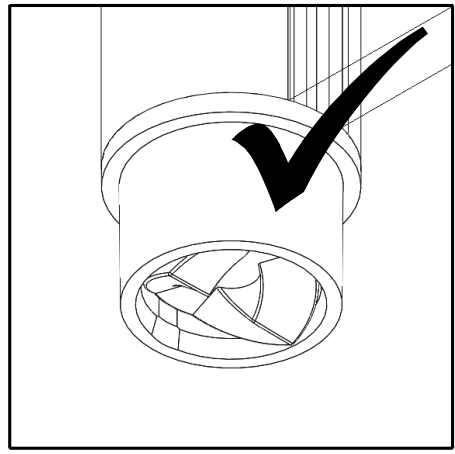
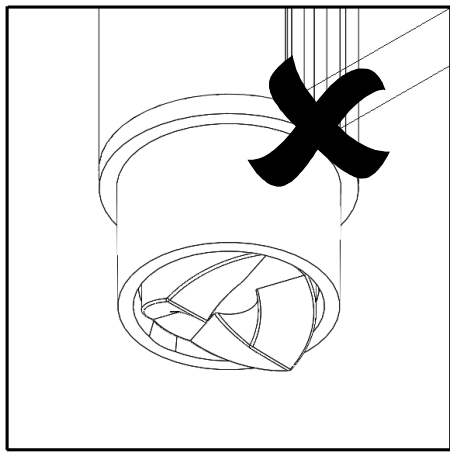
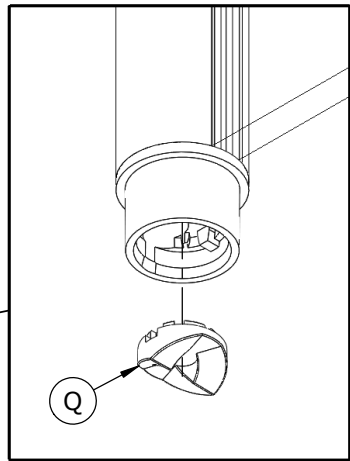
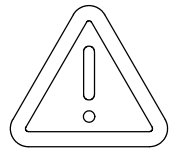
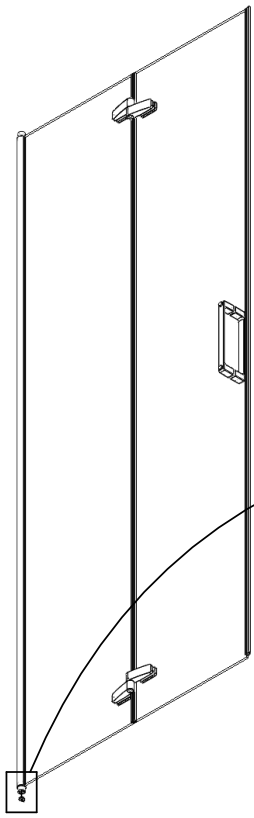

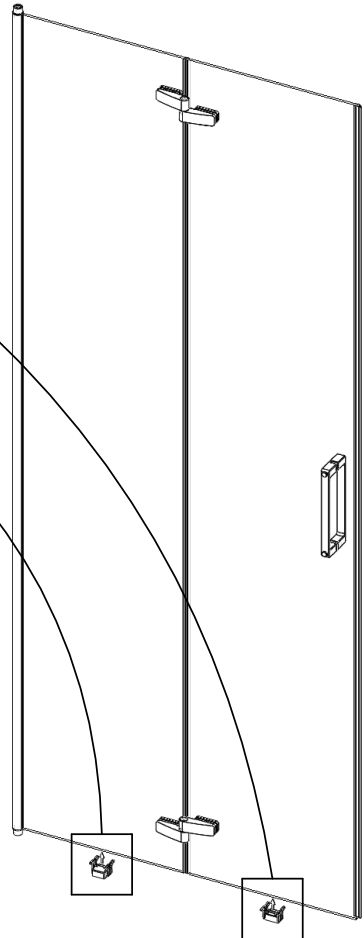
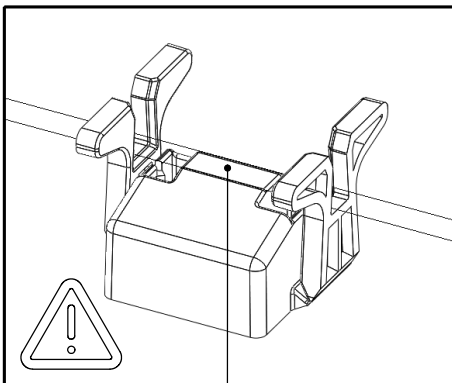
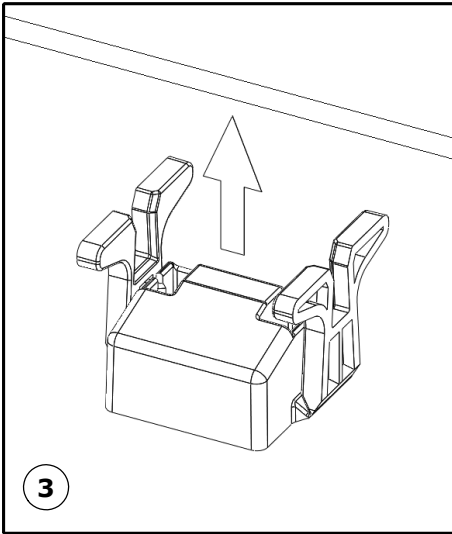
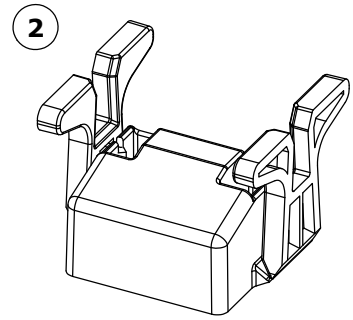
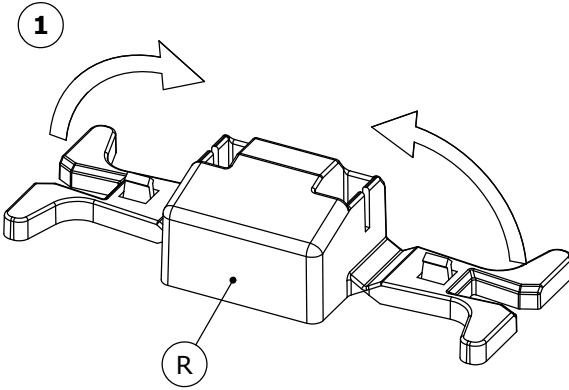

- Mettre en contact ● Put in contact
- Poner en contacto ● Mettere in contatto
- Mensen in contact te brengen ● Kontakte knüpfen

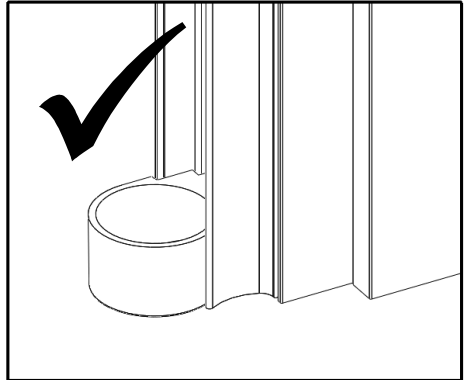
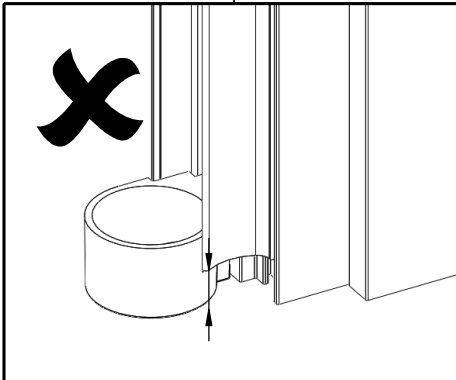
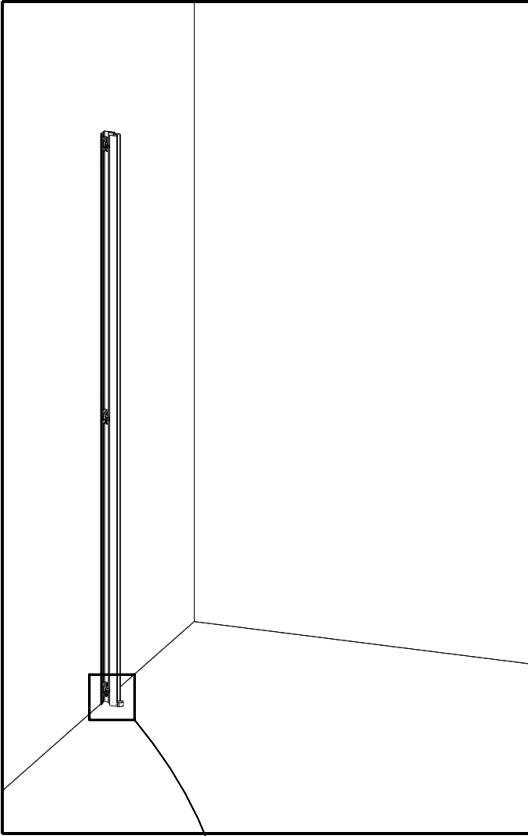

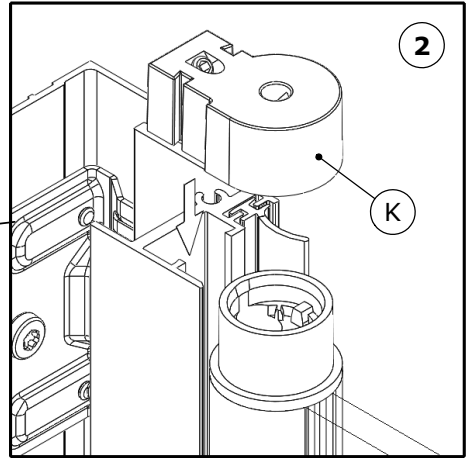
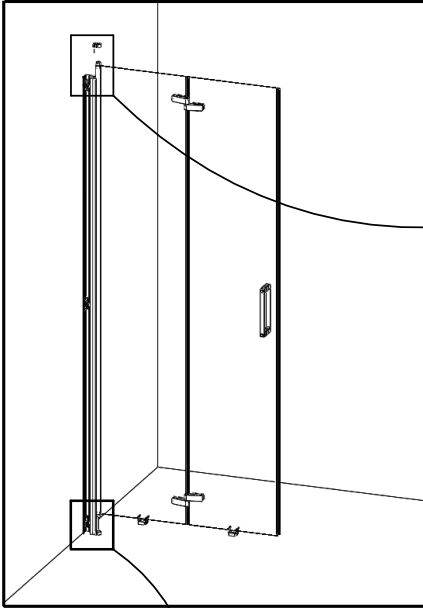

● Affleurant ● Flush  
 ● Afloramiento ● Affioramento  
 ● Doorspoelen ● Bündig

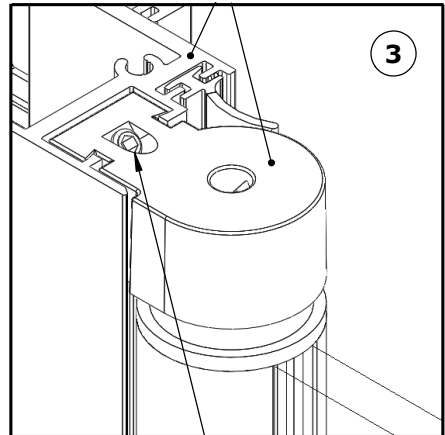
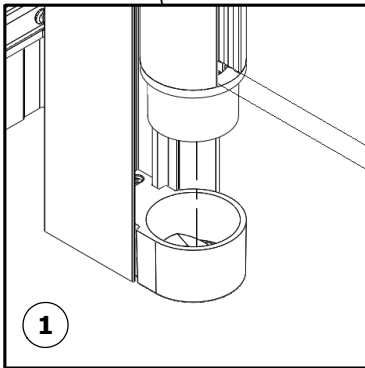

● Serrer fort ● Tighten hard  
 ● Apretar fuerte ● Serrare forte  
 ● Draai stevig vast ● Fest aanziehen

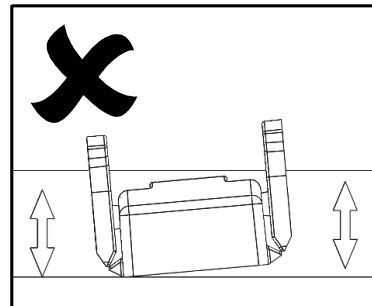
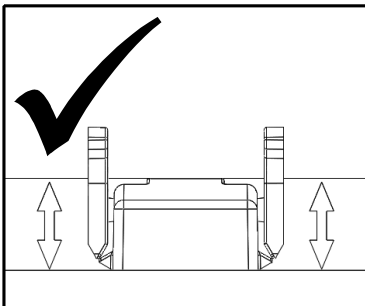

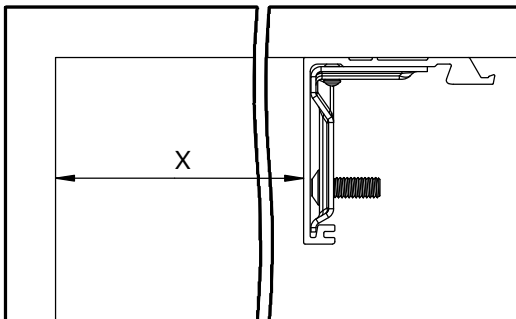
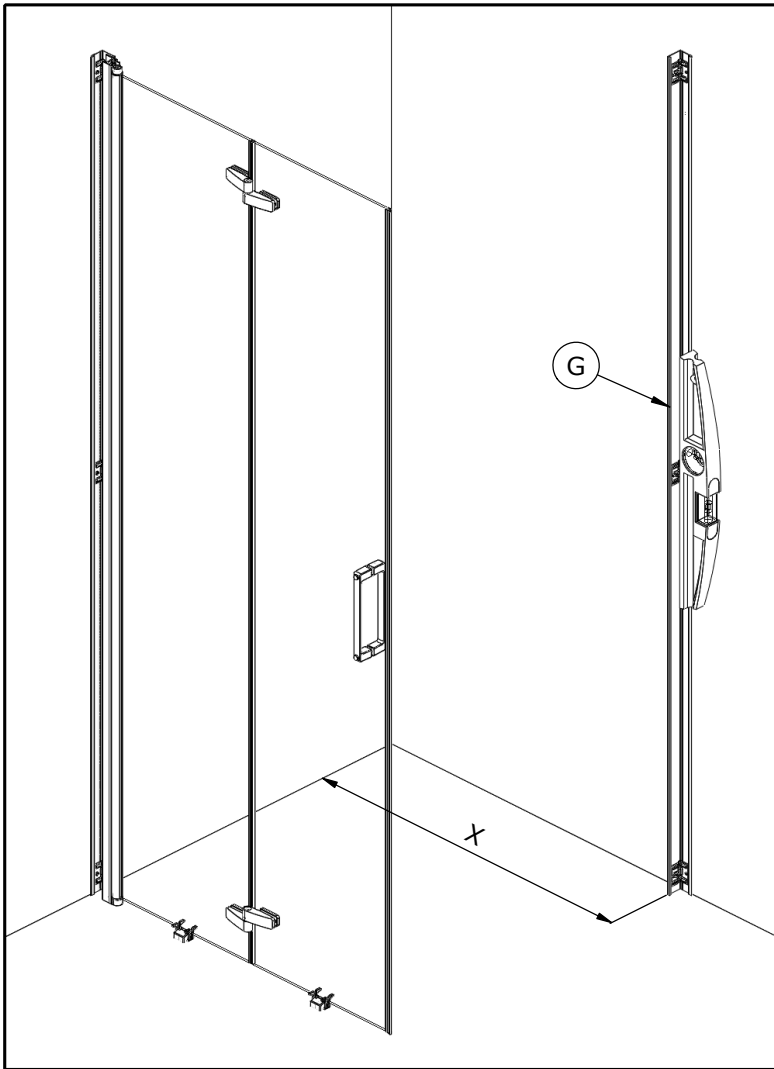

DIMENSIONS (cm)	X (mm)
70	630 - 645
75	680 - 685
80	730 - 745
85	780 - 785
90	830 - 845
95	880 - 885
100	930 - 945



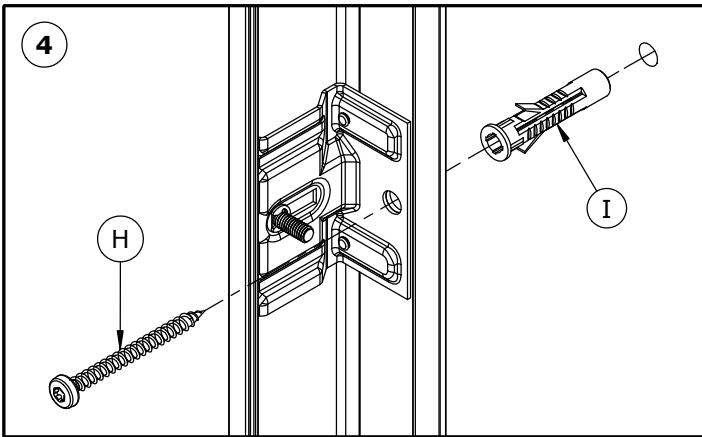
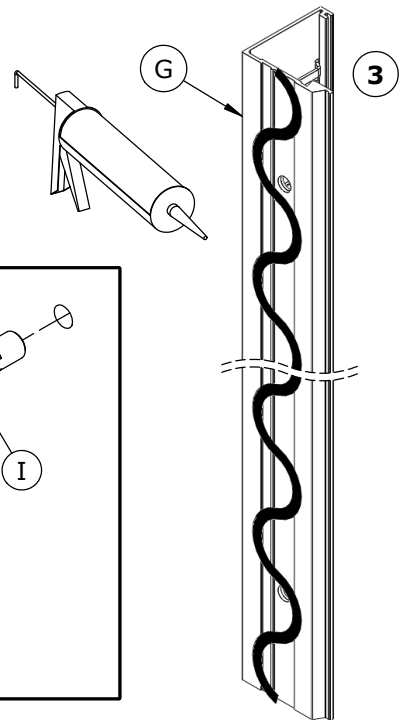
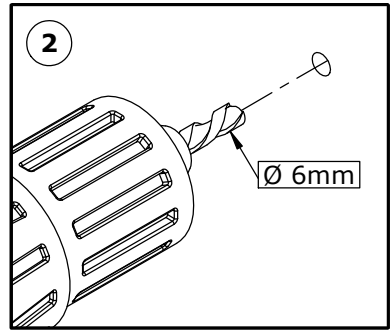
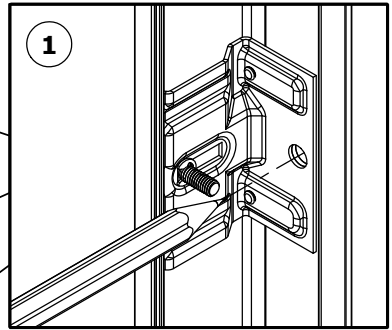
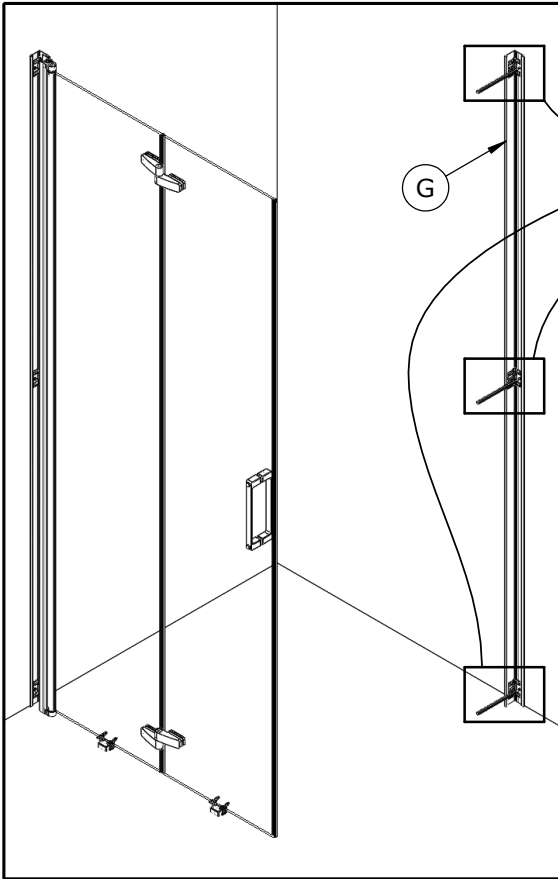

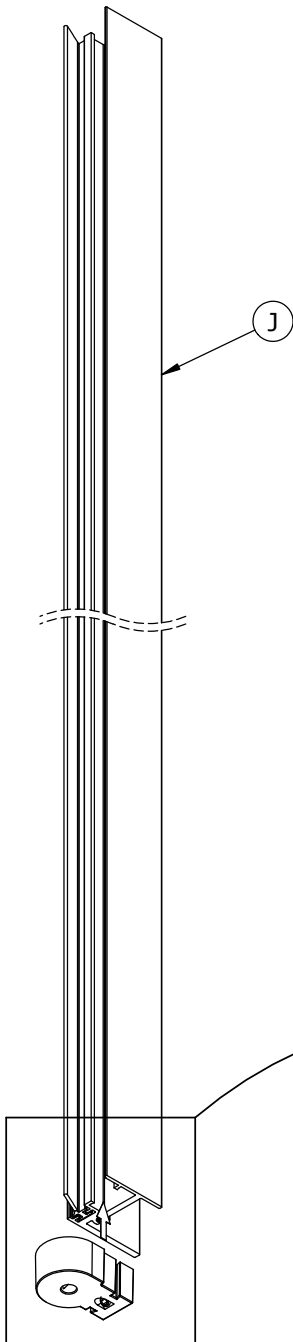

- Affleurant ● Flush  
 ● Afloramiento ● Affioramento  
 ● Doorspoelen ● Bündig

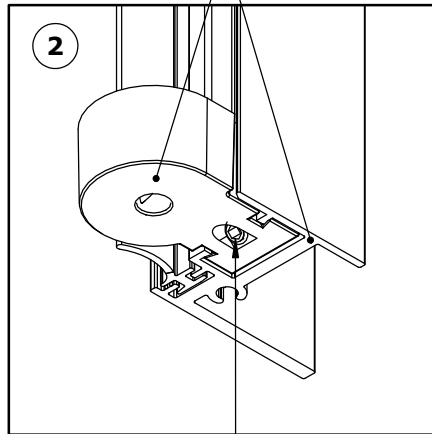

- Serrer fort ● Tighten hard  
 ● Apretar fuerte ● Serrare forte  
 ● Draai stevig vast ● Fest anziehen

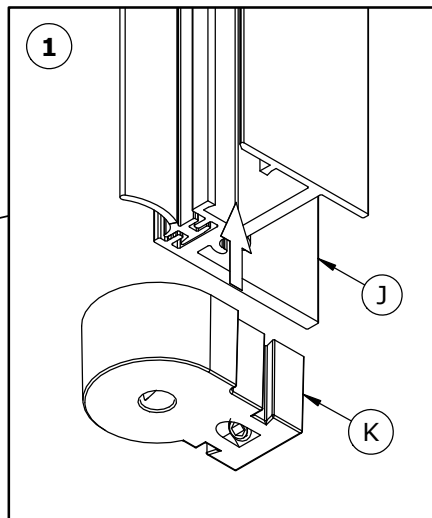

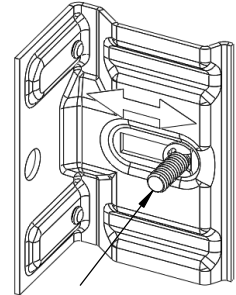
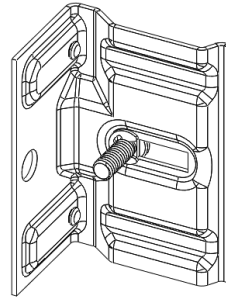
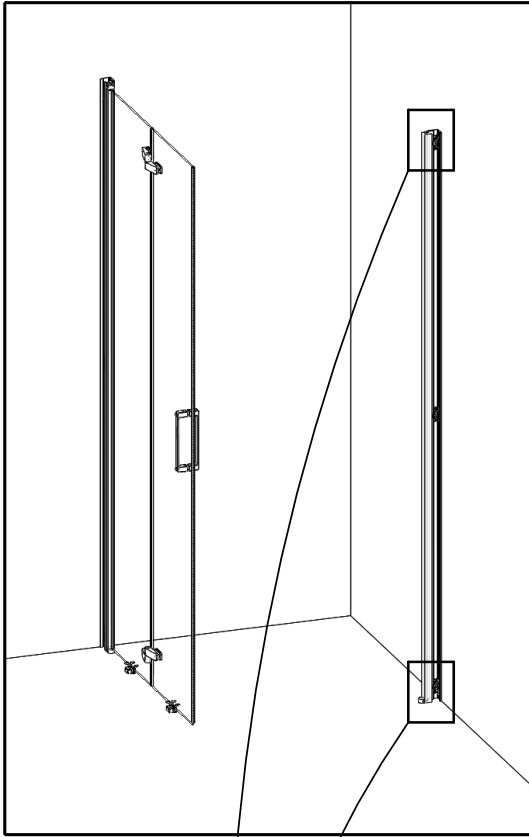

- Si nécessaire, desserrer, régler puis resserrer
- If necessary, loosen, adjust and retighten
- Si es necesario, afloje, ajuste y apriete
- Se necesario, allentare, regolare e stringere
- Draai los, indien nodig, stel af en draai vervolgens weer vast
- Falls erforderlich, lösen, einstellen und wieder festziehen

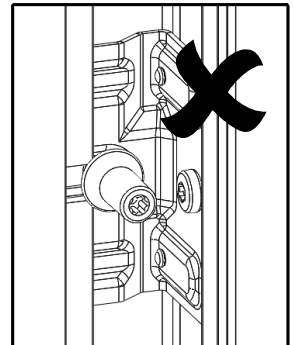
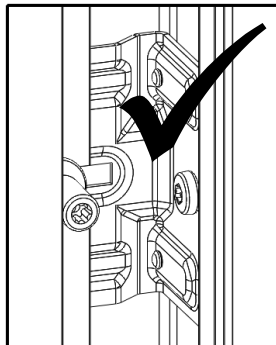
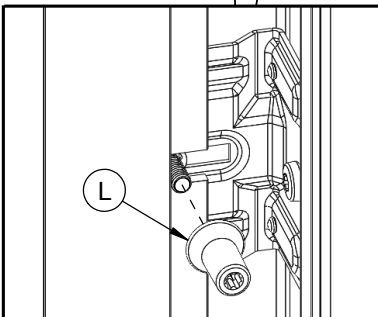

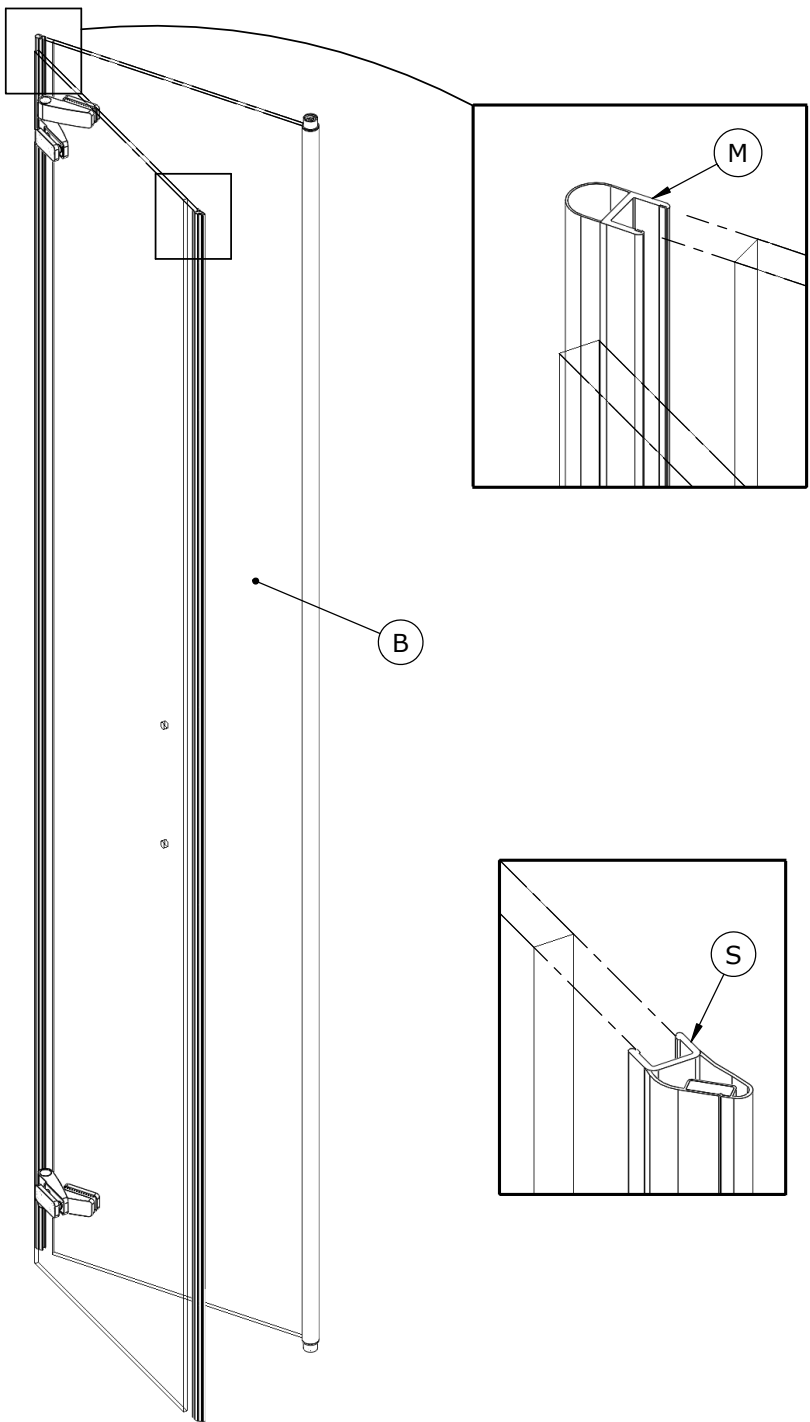

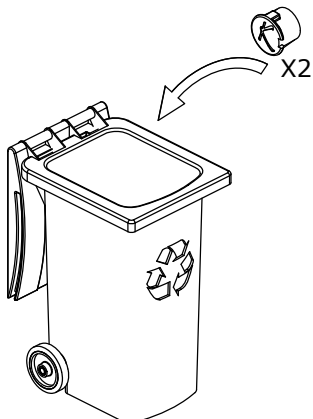
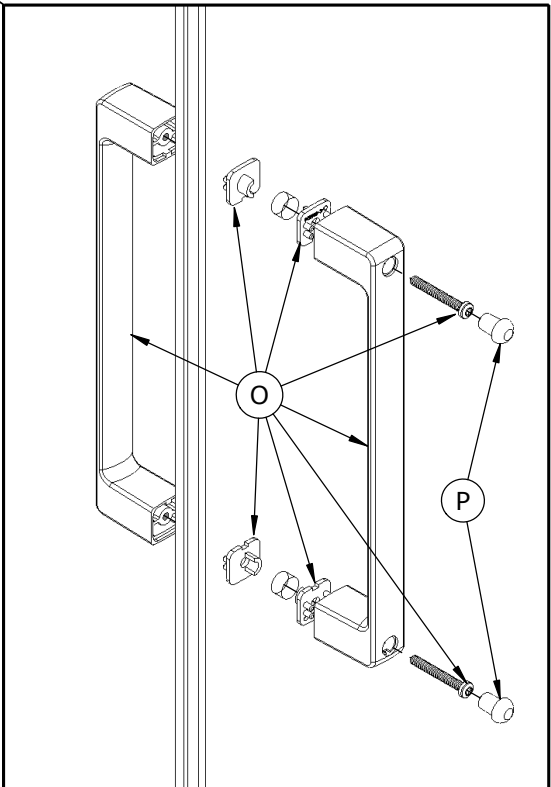
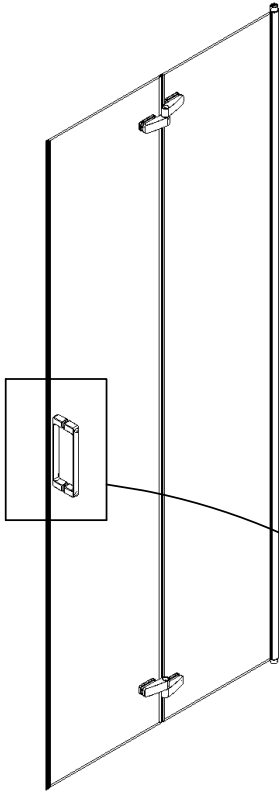

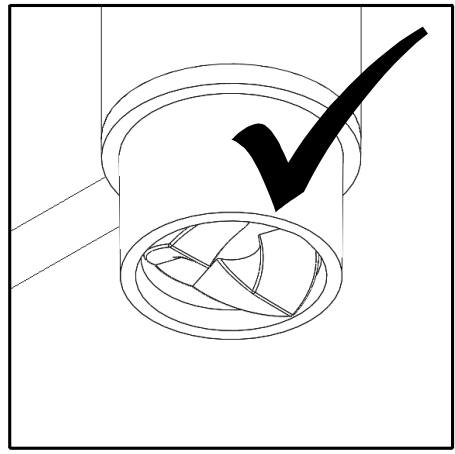
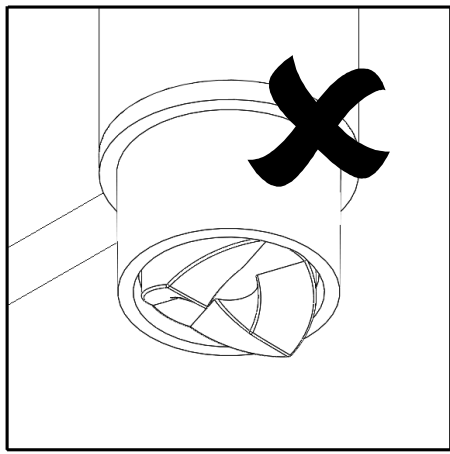
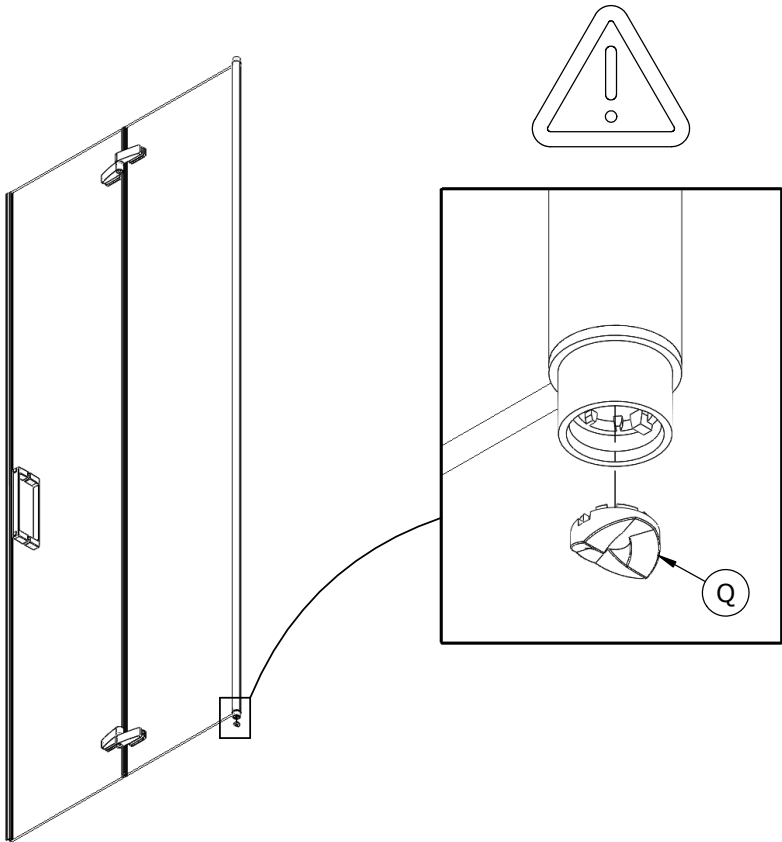

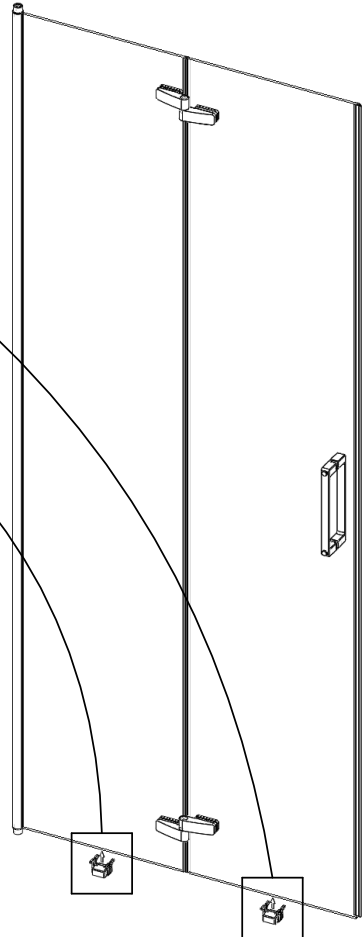
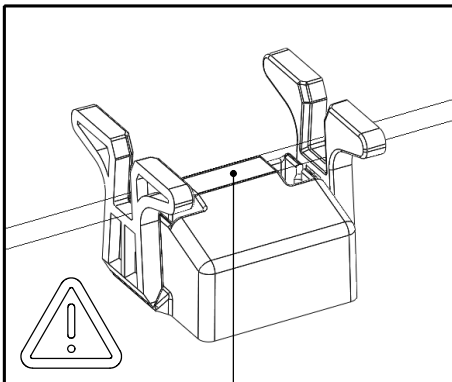
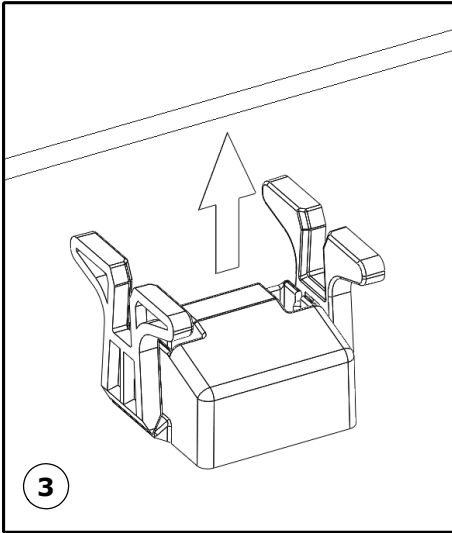
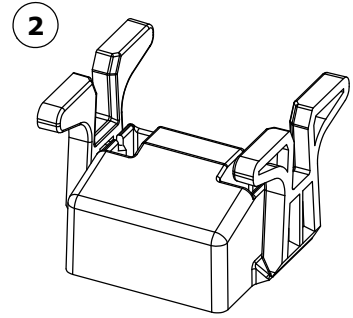
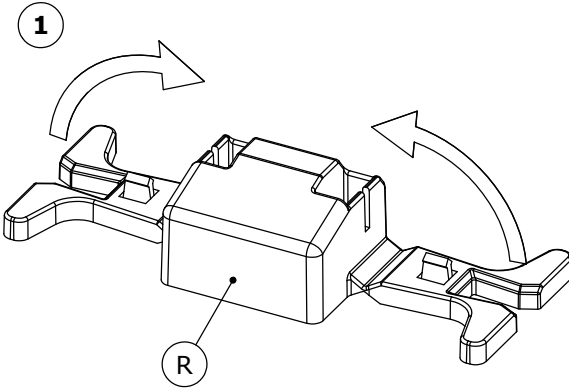

- Mettre en contact ● Put in contact
- Poner en contacto ● Mettere in contatto
- Mensen in contact te brengen ● Kontakte knüpfen

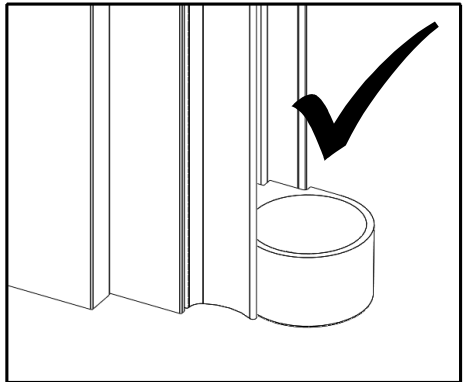
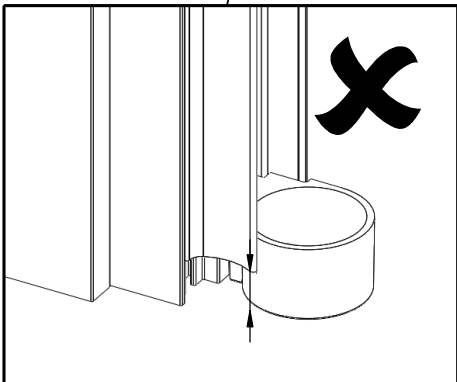
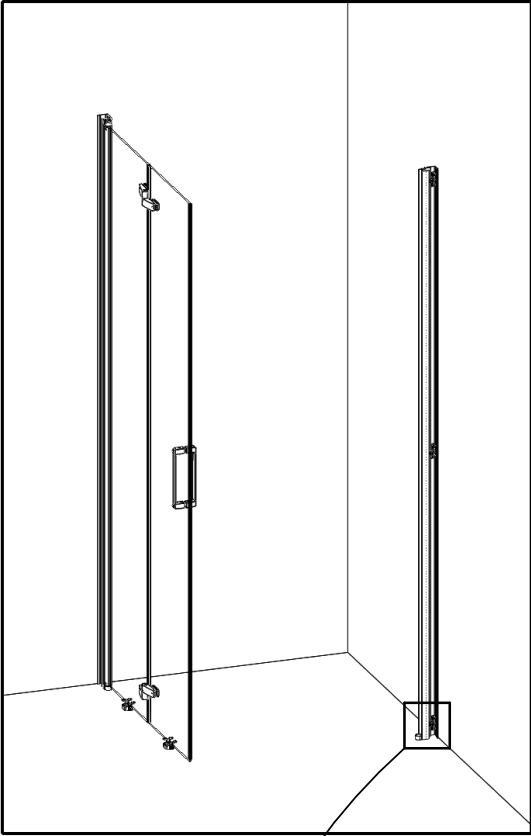



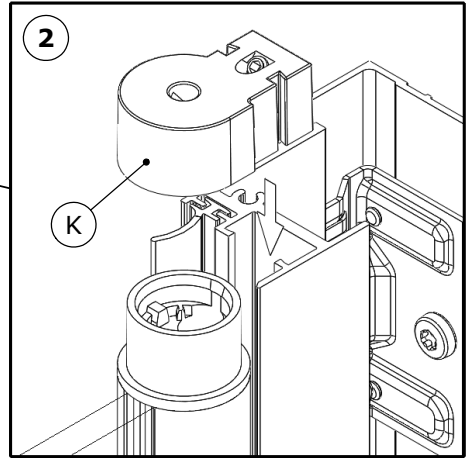
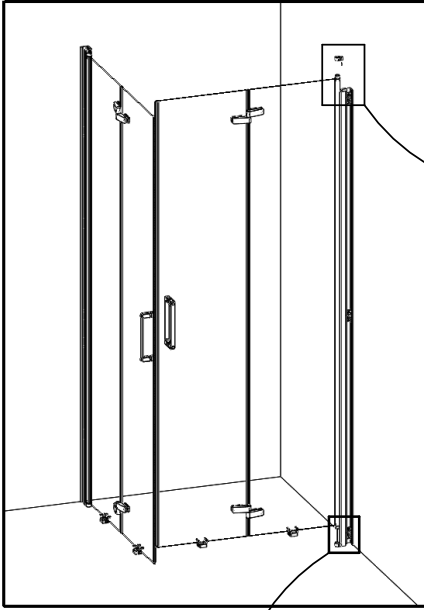

● Affleurant ● Flush  
 ● Afloramiento ● Affioramento  
 ● Doorspoelen ● Bündig

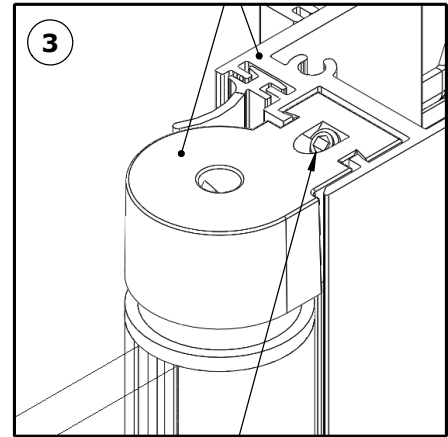
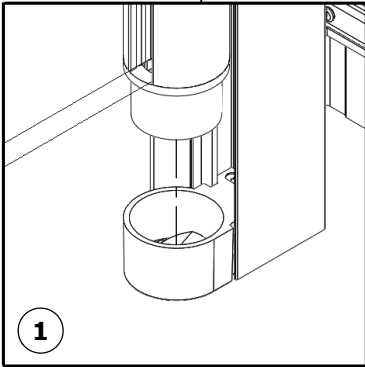

● Serrer fort ● Tighten hard  
 ● Apretar fuerte ● Serrare forte  
 ● Draai stevig vast ● Fest anziehen

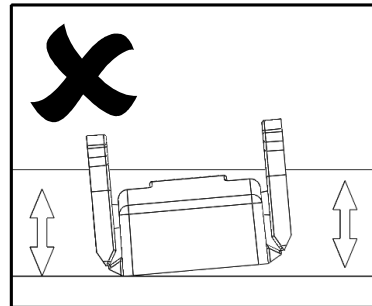
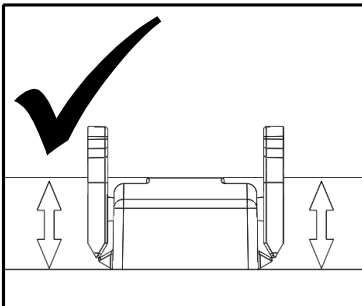

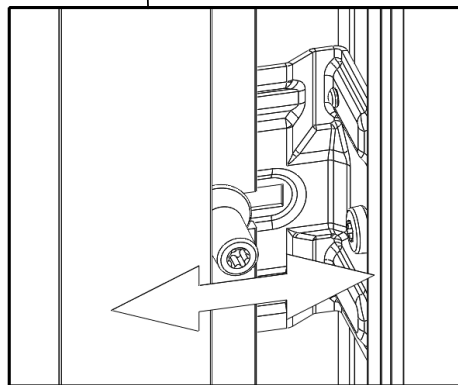
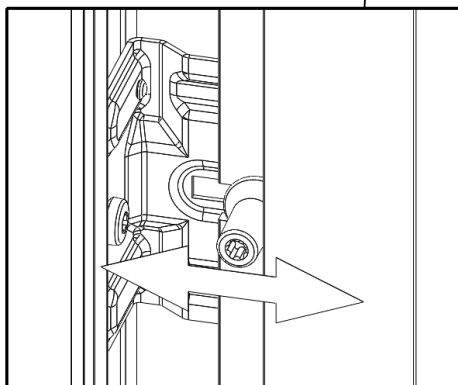
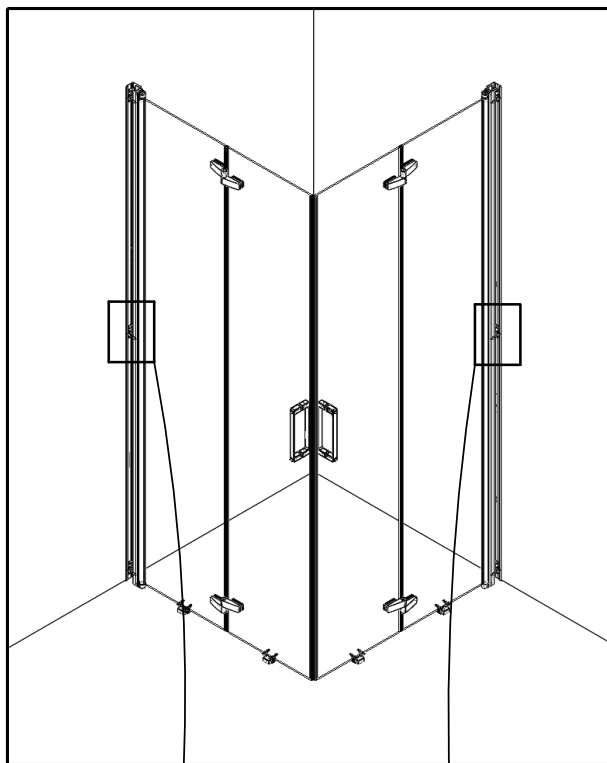

- Si nécessaire, desserrer, régler puis resserrer
- If necessary, loosen, adjust and retighten
- Si es necesario, afloje, ajuste y apriete
- Se necessario, allentare, regolare e stringere
- Draai los, indien nodig, stel af en draai vervolgens weer vast
- Falls erforderlich, lösen, einstellen und wieder festziehen

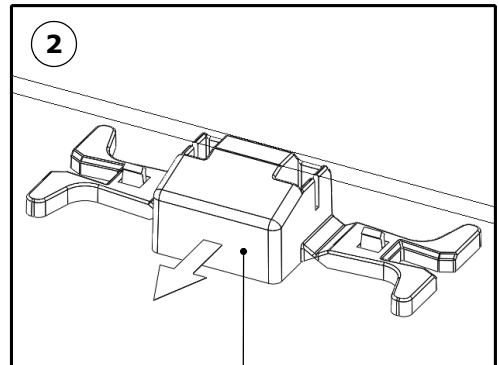
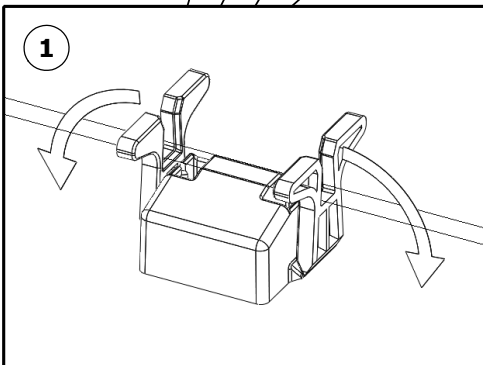
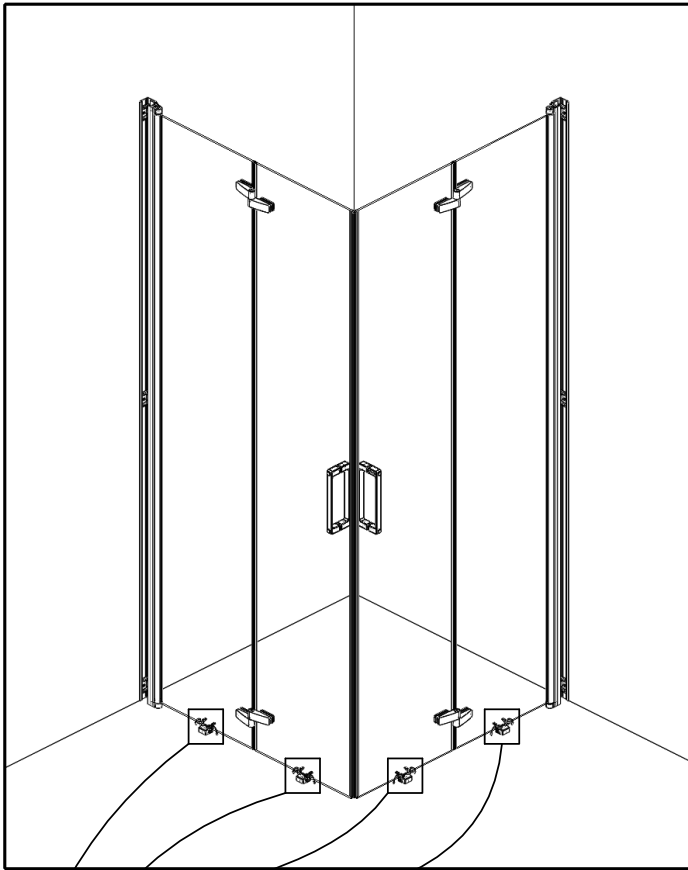

- Retirer ● Remove  
 ● Quitar ● Togliere  
 ● Verwijderen ● Entfernen

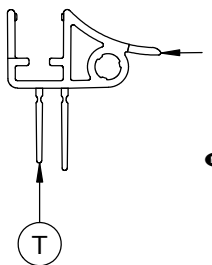
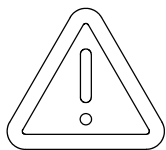

- Intérieur
- Inside
- Interior
- Interno
- Binnenkant
- Innen

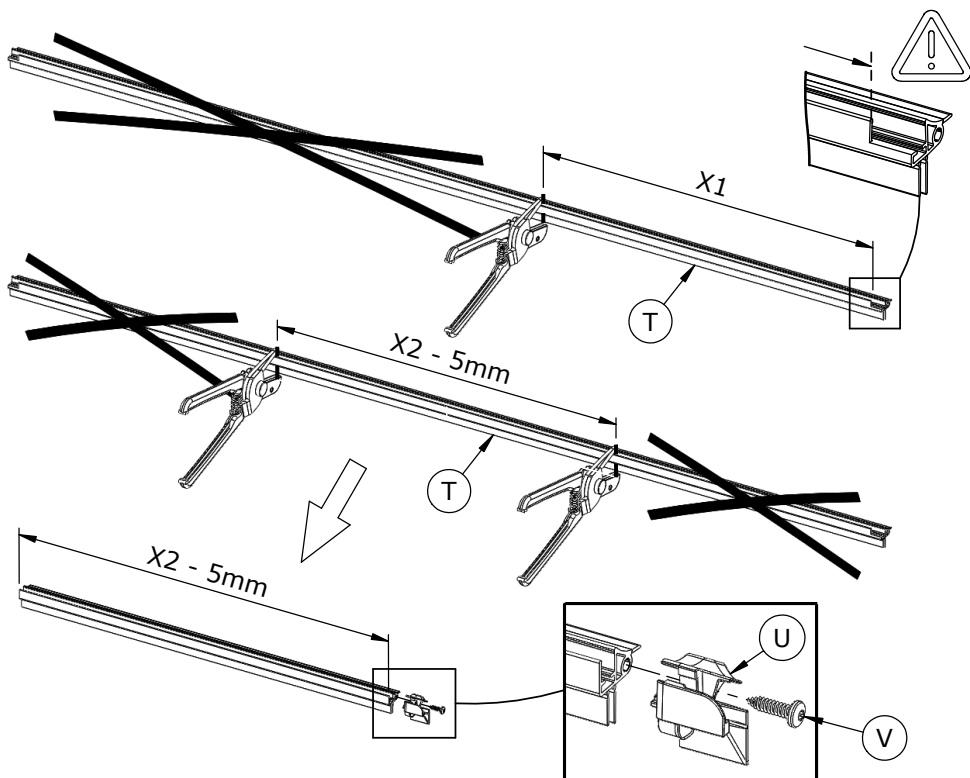
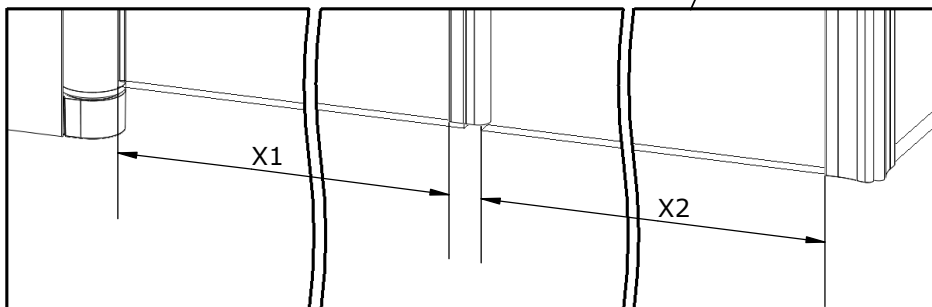
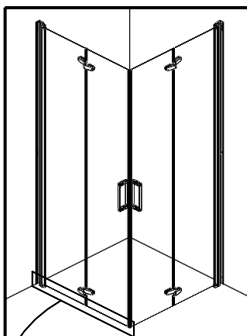

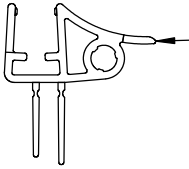

- Intérieur
- Inside
- Interior
- Interno
- Binnenkant
- Innen

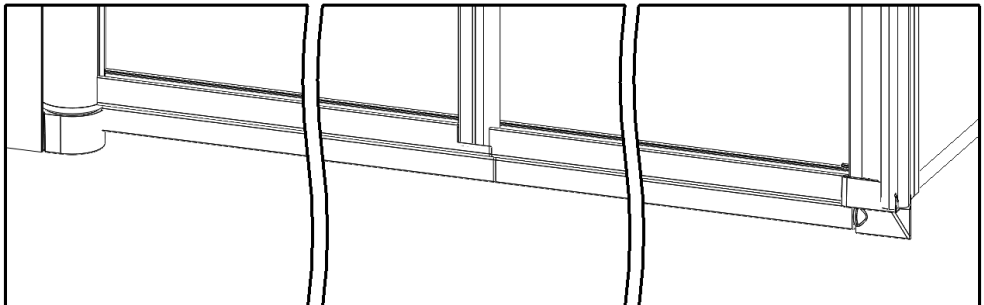
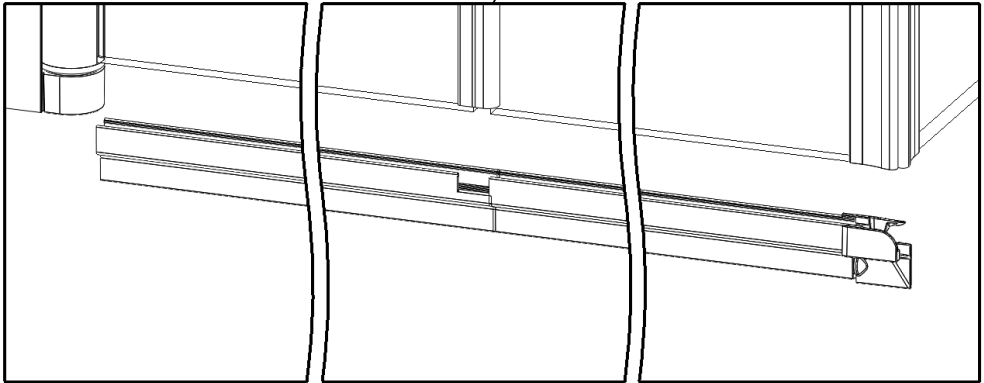
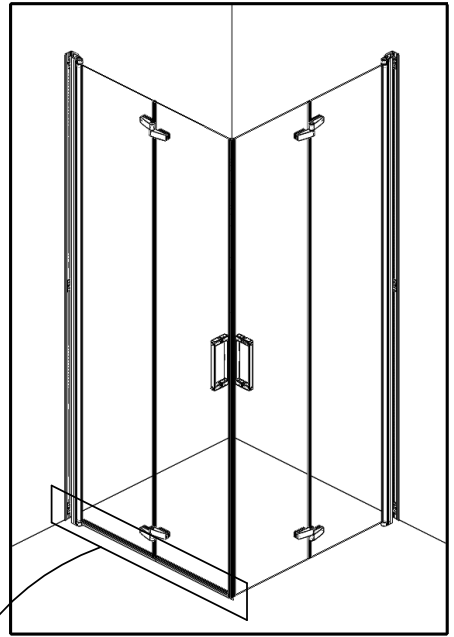

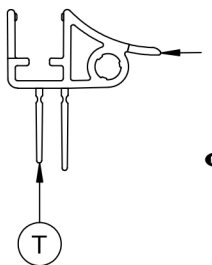

- Intérieur
- Inside
- Interior
- Interno
- Binnenkant
- Innen

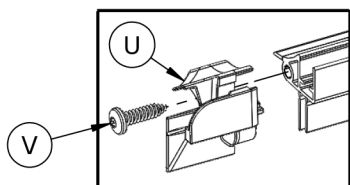
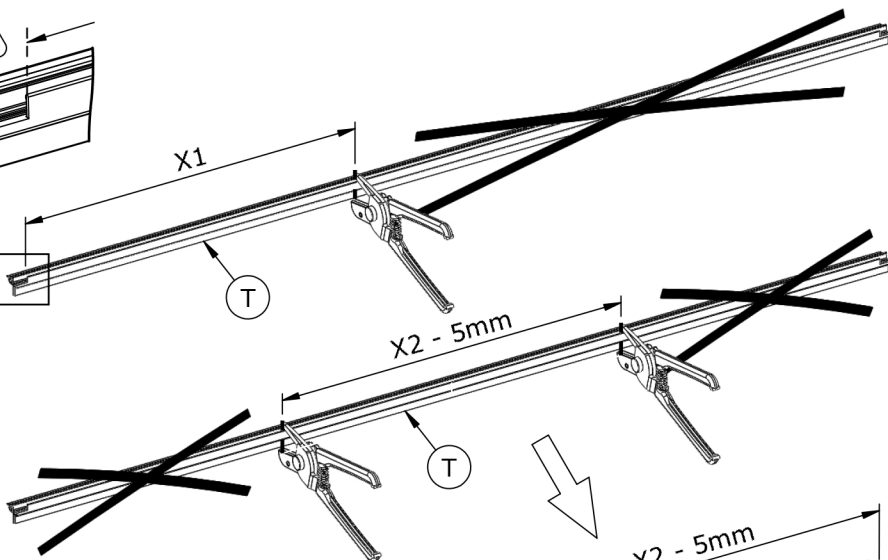
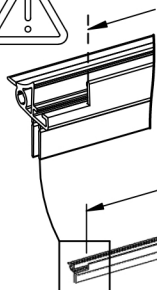
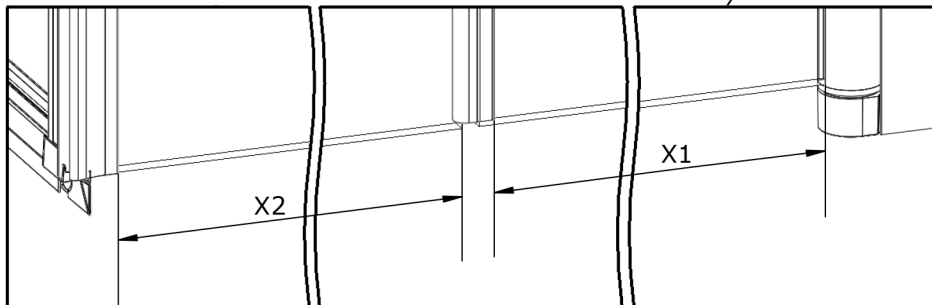
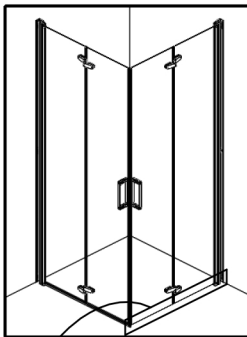

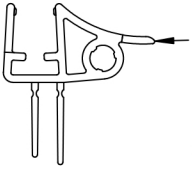

- F Intérieur
- GB Inside
- E Interior
- I Interno
- NL Binnenkant
- D Innen

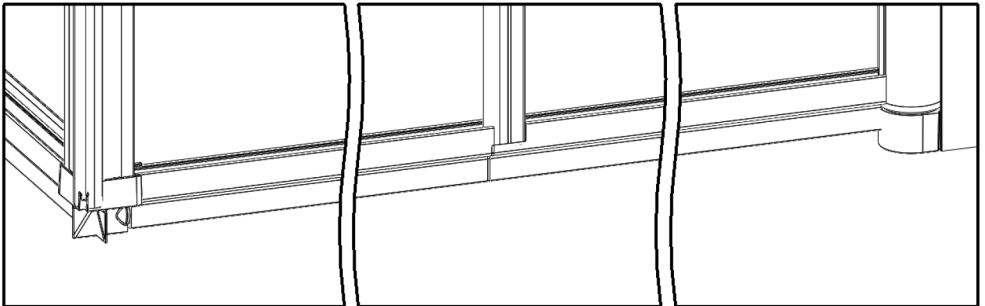
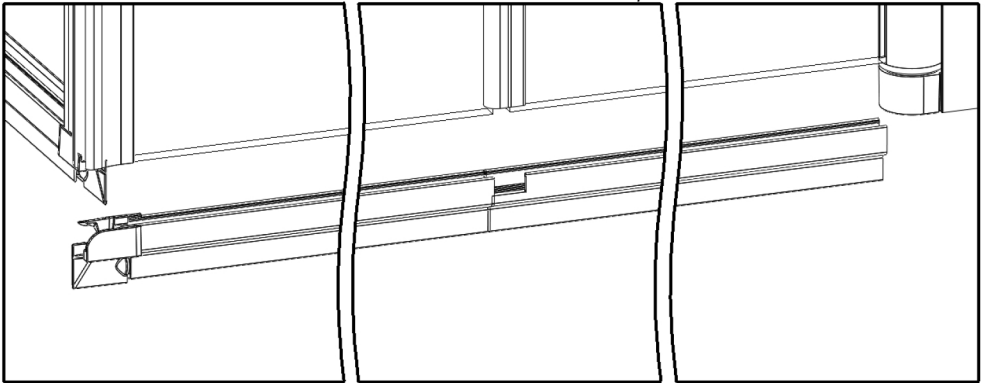
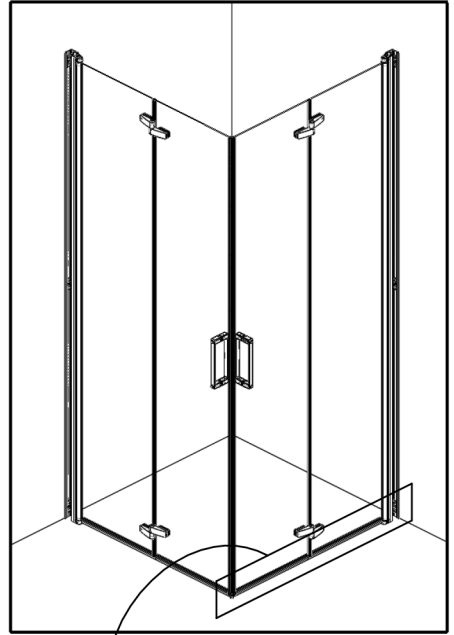

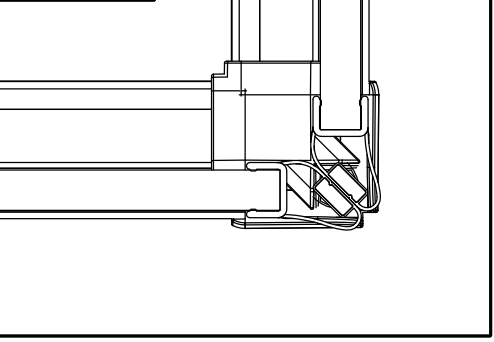
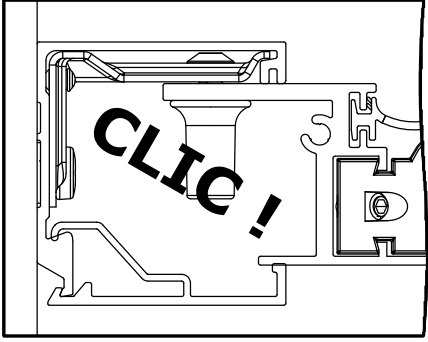
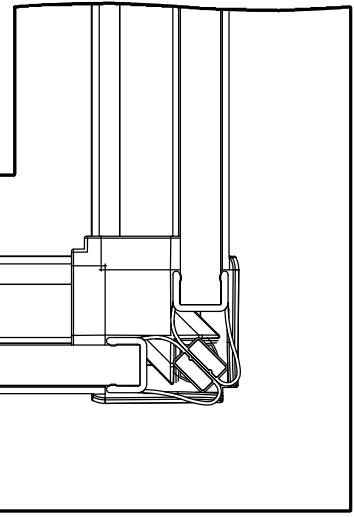
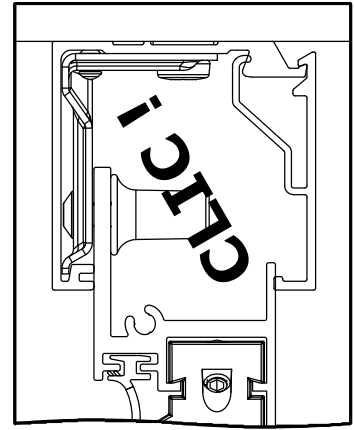
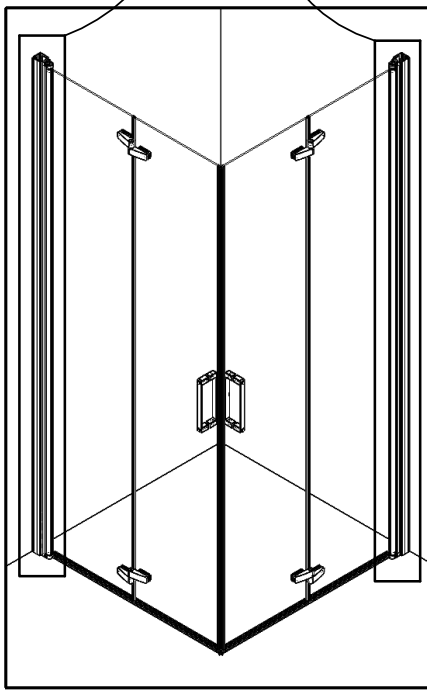
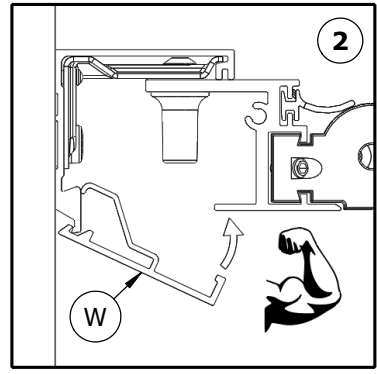
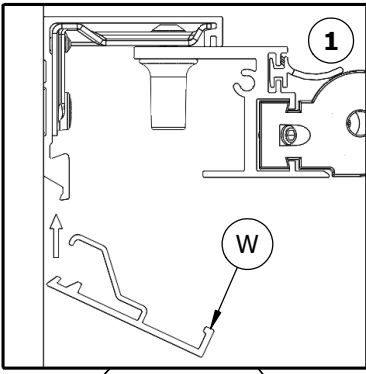



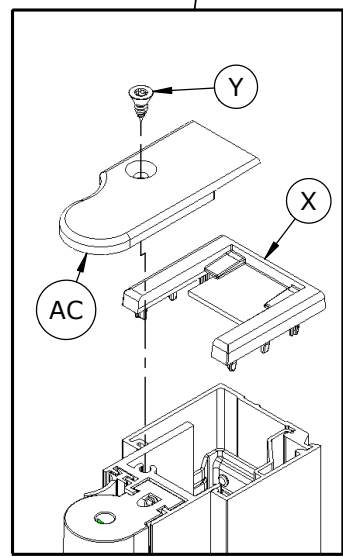
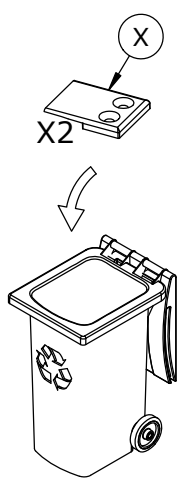
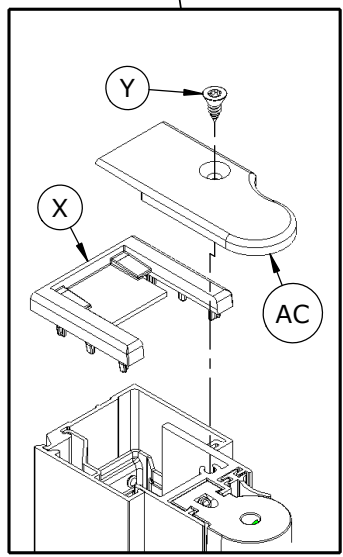
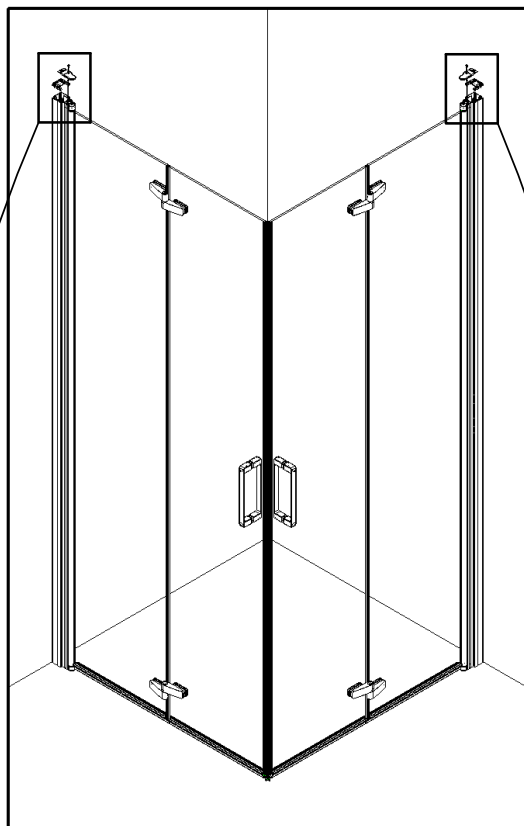



- Ⓕ Sens de montage
- Ⓖ Mounting direction
- Ⓔ Sentido de instalación
- Ⓛ Senso di montaggio
- Ⓜ Montagerichtung
- Ⓝ Montagerichtung

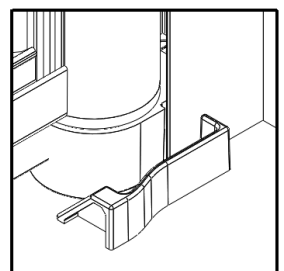
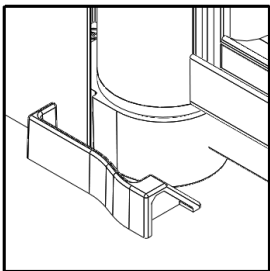
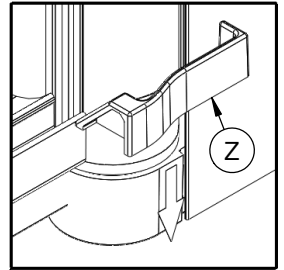
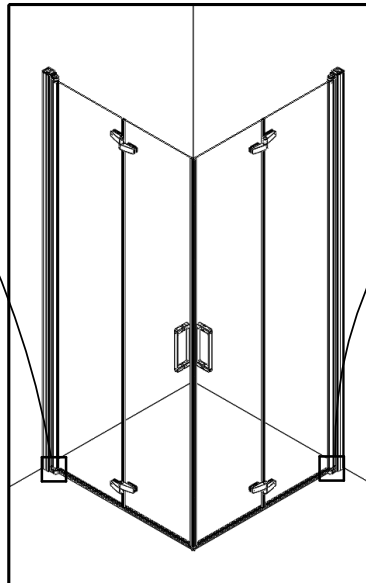
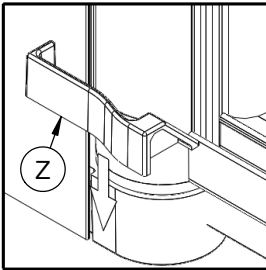
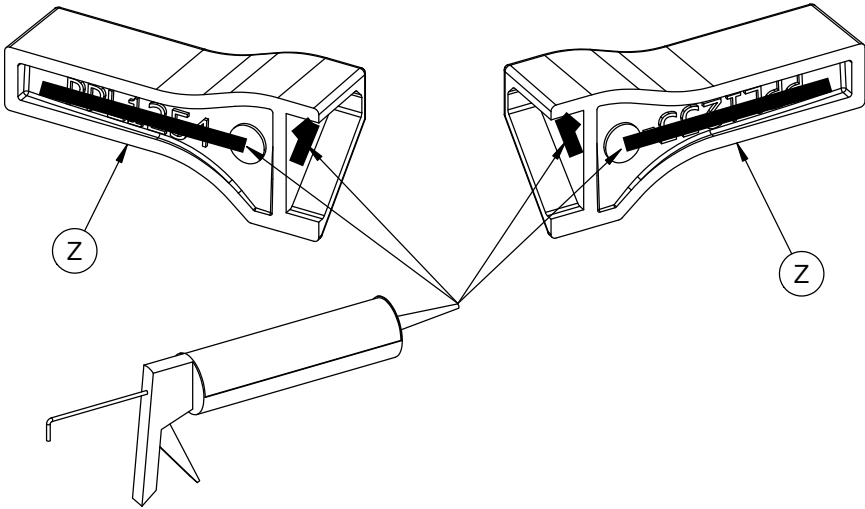

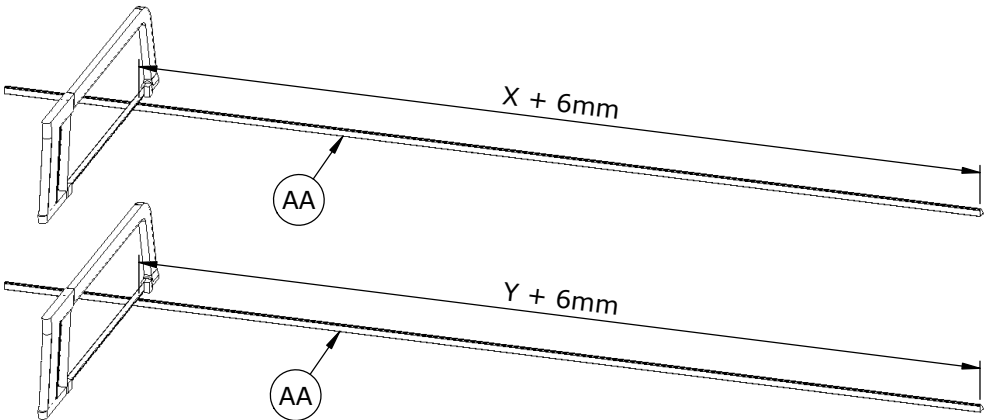
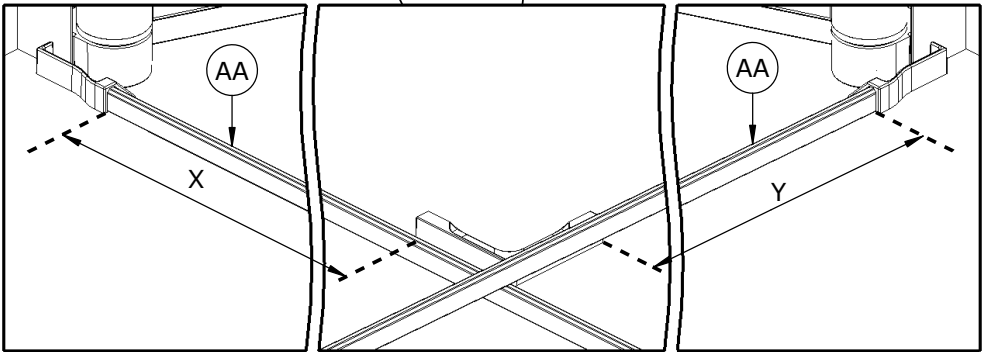
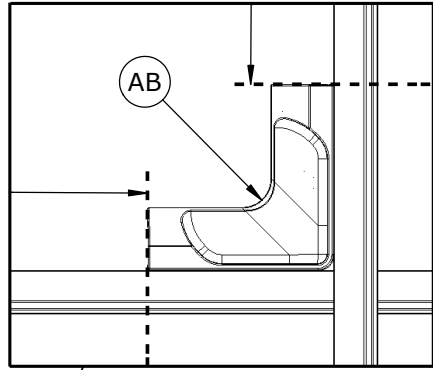
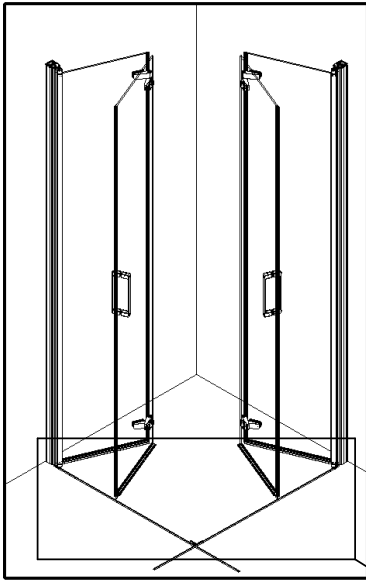

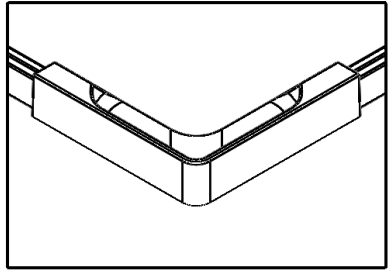
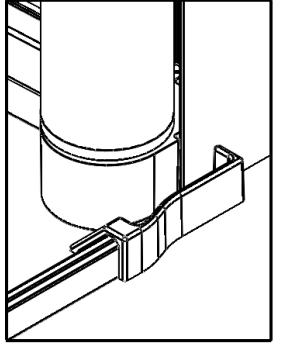
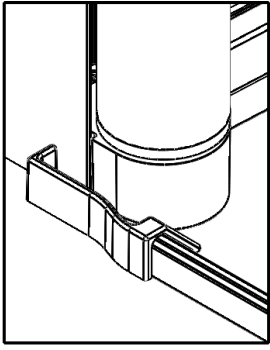
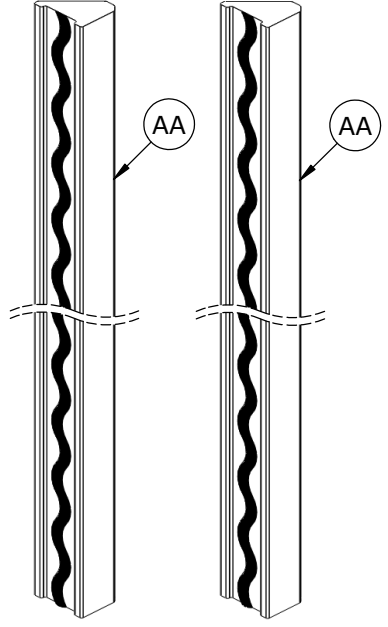
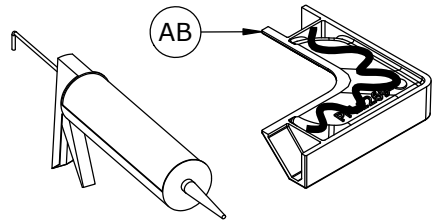
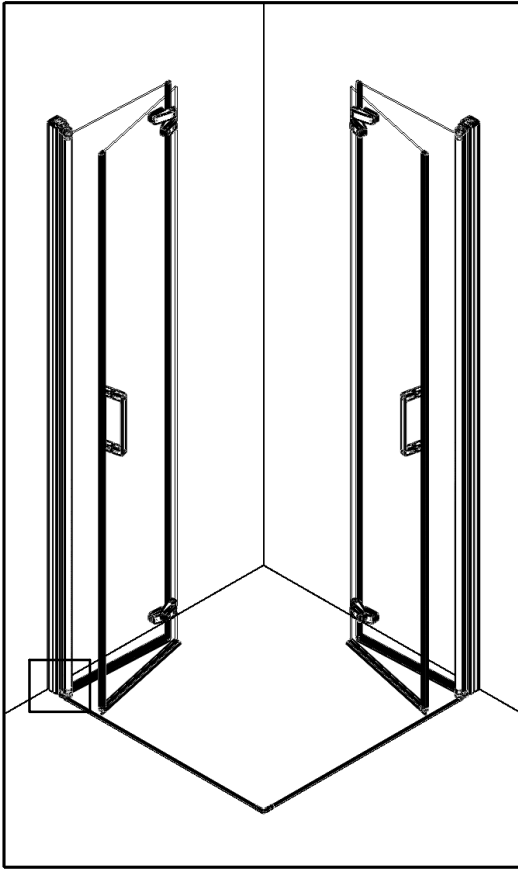

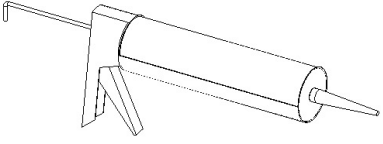

24H

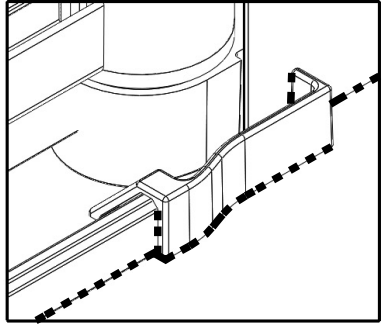
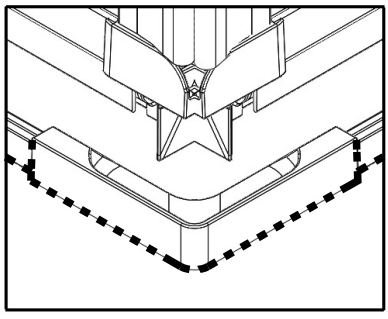
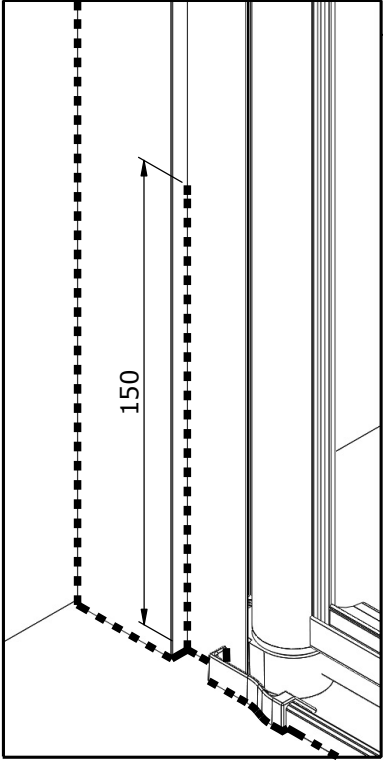
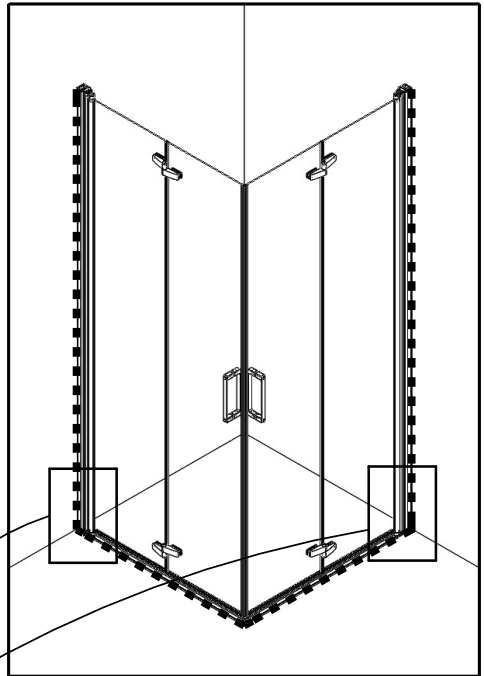



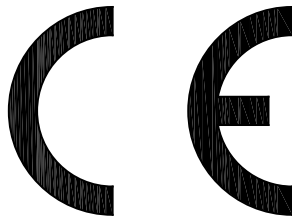

AQUAPRODUCTION, Site industriel,  
F - 44680 Chaumes-en-Retz

18

**EN 14428**

Paroi de douche, fabriquée en verre de silicate  
sodo-calcique de sécurité trempé thermiquement

Aptitude au nettoyage : réussite

Résistance à l'impact/propriétés de fragmentation : réussite

Durabilité : réussite



**SAV**  
**SERVICE HELPLINES**  
**ASSISTENZA POST-VENDITA**  
**SERVICIO POSTVENTA**

**FRANCE**

02 40 21 29 45

**SCHWEIZ**

(01) 748 17 44

**UK**

020 8842 0033

**ESPANA**

93 544 60 76

**IRELAND**

04697 33102

**NEDERLAND**

+31 475 487 100

**DEUTSCHLAND**

+49 (0) 6074 / 30928 0

**BELGIE**

+31 475 487 100

**ITALIA**

(0382) 6181

**BELGIQUE**

+31 475 487 100

**OSTEREICH**

+43 1 710 60 70

**РОССИЯ**

963 19 40, 773 67 22