

- F Notice de montage
- GB Installation instructions
- E Manual de instalación
- I Istruzioni di montaggio
- NL Montage-instructies
- D Montageanleitung

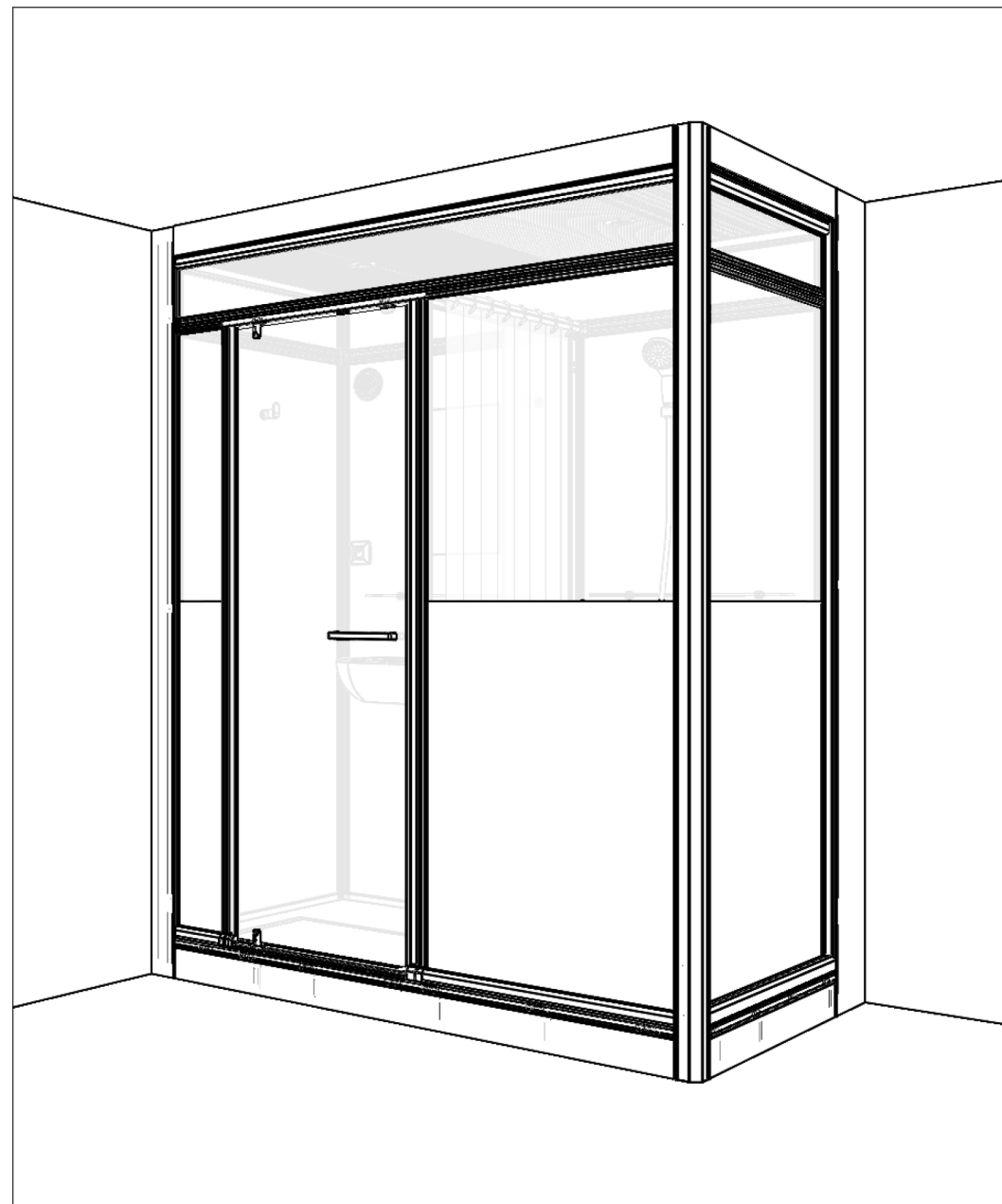

1/2



- Attention aux étapes :
- Check installation steps :
- Atención a los pasos :
- Attenzione ai passi :
- Aandacht voor de stappen :
- Achtung vor den Schritten :

P. 4 - 12

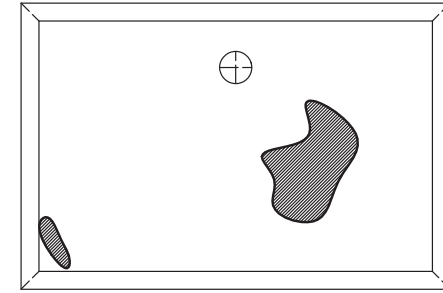
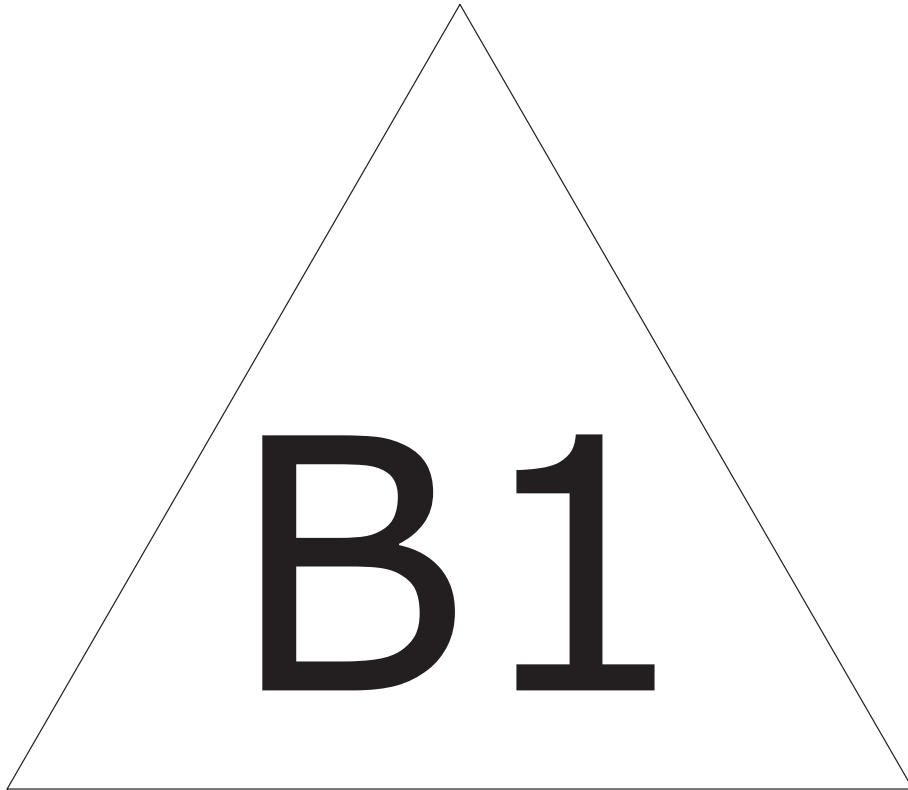

- F** D'éventuelles irrégularités de surface sur le dessous de votre sol n'empêchent pas une installation conforme aux préconisations de pose. La colle (polyuréthane ou MS polymère) comblera facilement ces manques lors du collage.
- GB** Any surface irregularities on the underside of the floor have no influence on the installation according to the installation recommendations. The adhesive (polyurethane or MS polymer) compensates for these unevenness when bonding the feet off without any problems.
- E** Posibles irregularidades de la superficie en la parte inferior del suelo no impida la instalación de acuerdo con las recomendaciones de instalación. El adhesivo (poliuretano o polímero MS) rellenará fácilmente estos huecos al pegar los pies.
- I** Eventuali irregolarità della superficie nella parte sotto del pavimento non impediscono l'installazione in base alle raccomandazioni di montaggio. La colla (poliuretano o MS polimero) riempirà facilmente queste lacuna quando si incollano i piedini.
- NL** Eventuele onregelmatigheden in de vlakke onderzijde van uw vloer vormen geen belemmering voor een installatie conform aan de gestelde richtlijnen. De lijm (polyurethaan of MS-polymeer) vult eventuele openingen makkelijk op tijdens het lijmen.
- D** Eventuelle Unregelmäßigkeiten der Oberfläche an der Unterseite Ihres Bodens haben keinen Einfluss auf die Installation gemäß den Einbauempfehlungen. Der Klebstoff (Polyurethan oder MS-Polymer) gleicht diese Unebenheiten beim Verkleben problemlos aus.



F Aspirer le dessous de votre sol avant la pose

GB Vacuum the bottom of the floor before installation

E Aspirar la parte inferior de su suelo antes de instalarlo



I Aspirare la parte sottostante del pavimento prima dell'installazione

NL Stofzuig de bodem van de vloer voor de installatie

D Saugen Sie den Boden des Bodens vor der Installation ab

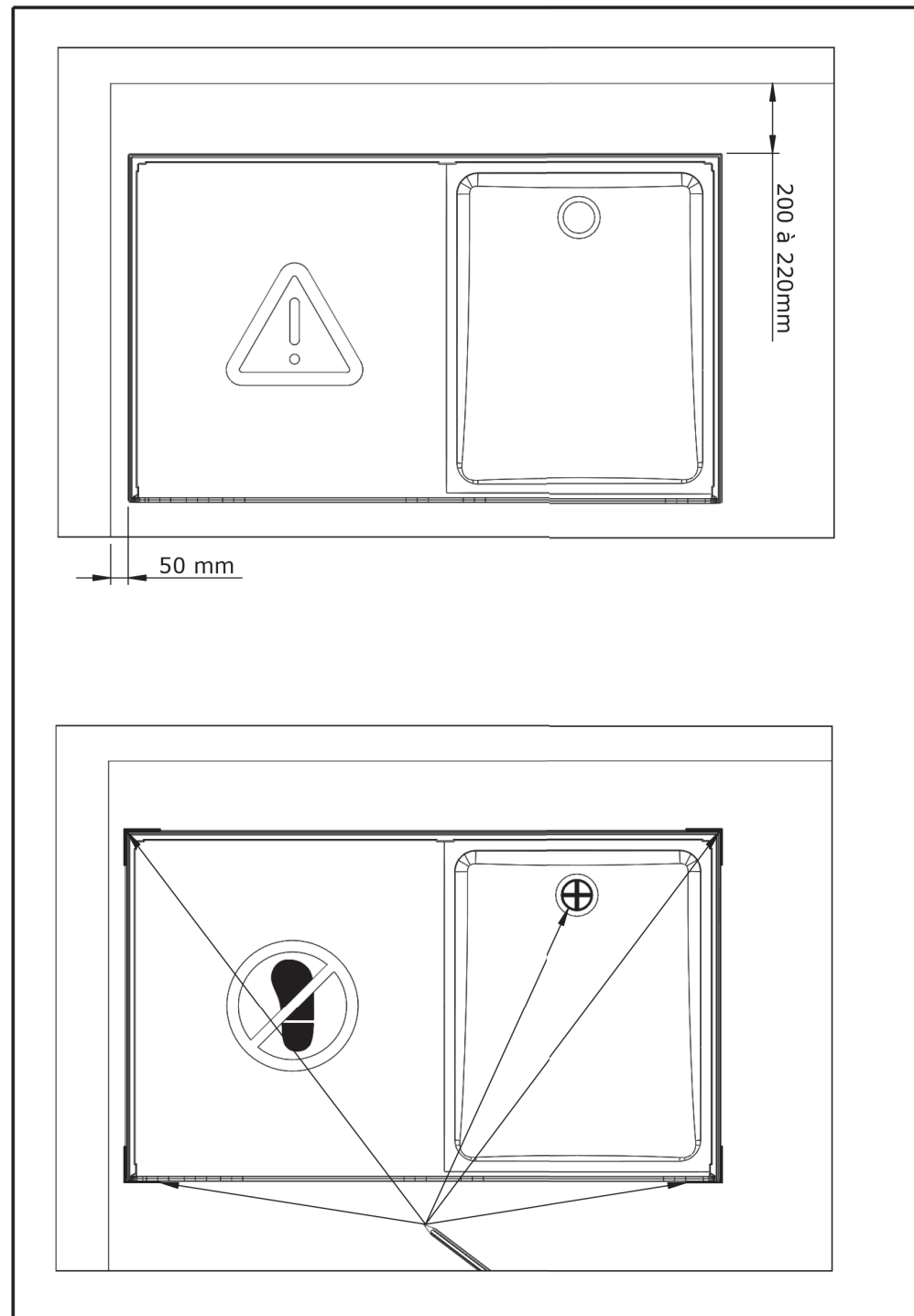
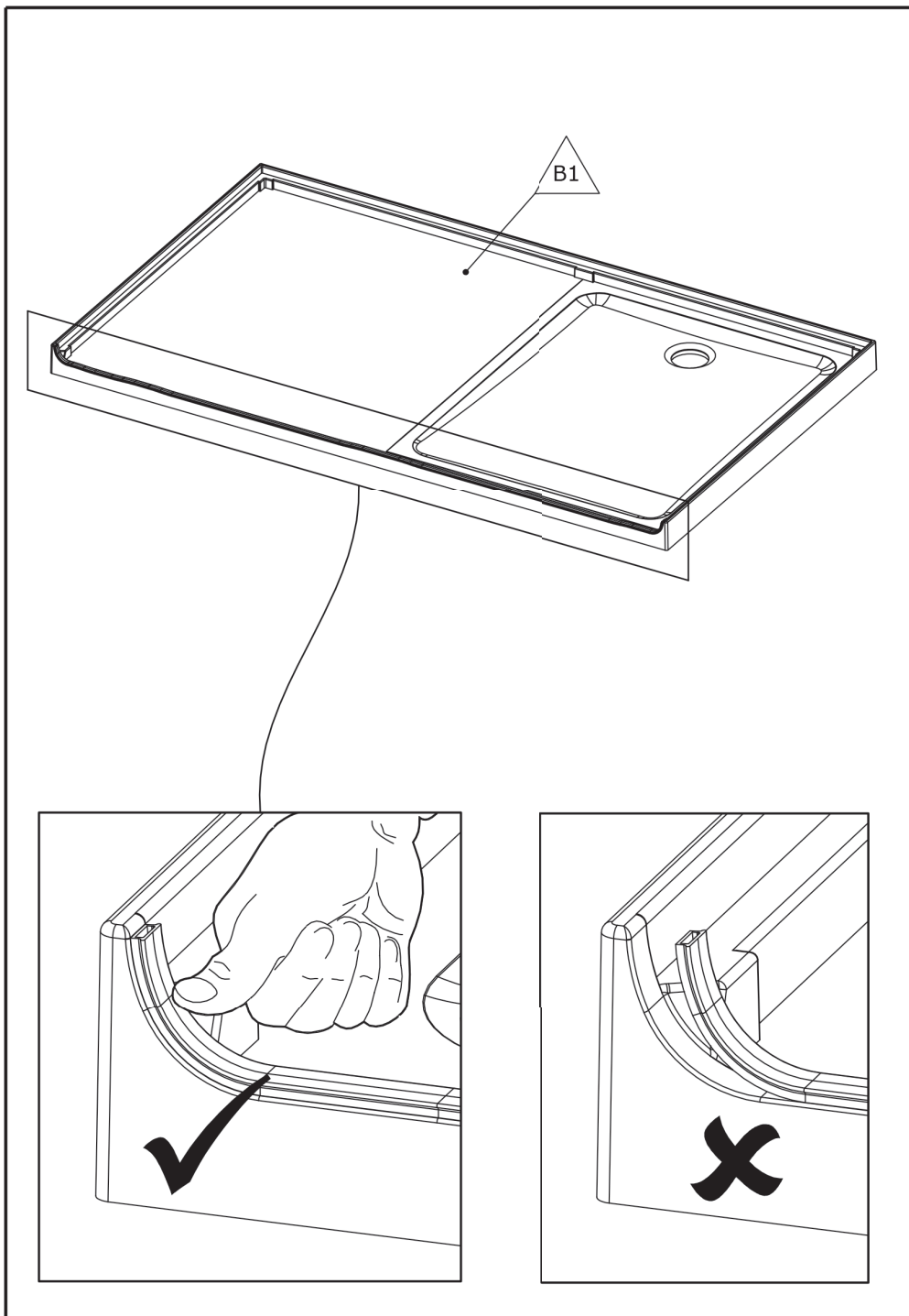

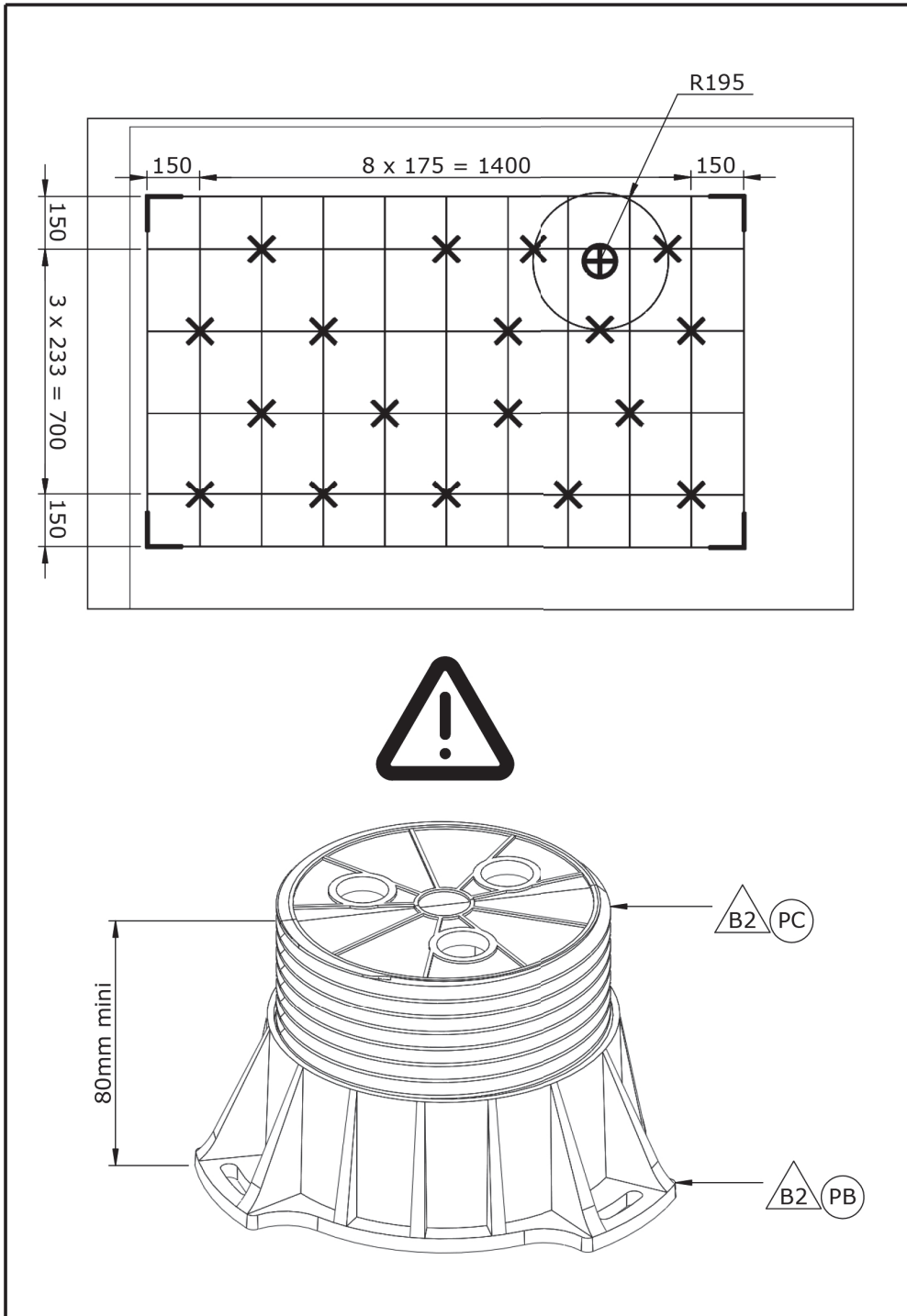

● Pose de sol avec pieds ● Laying the floor with adjustable feet
 ● Instalación del suelo con pies ● Posa del pavimento con piedi
 ● Montage van vloer op poten ● Installation der Boden mit Füßen

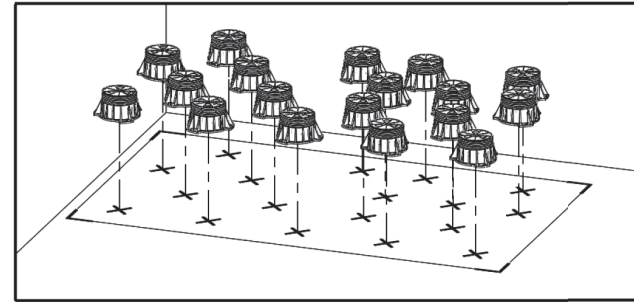

● Colle polyuréthane
 ● Polyurethane adhesive
 ● Pegamento de poliuretano
 ● Adesivo poliuretano
 ● Polyurethaan kit
 ● Polyurethan-klebstoff

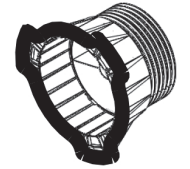
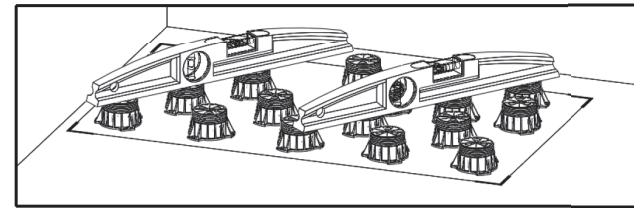
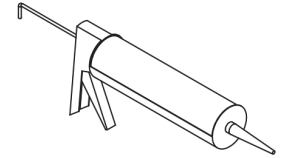

● Pose de sol sans pieds ● Laying the floor without feet
 ● Instalación del suelo sin pies ● Posa del pavimento senza piedi
 ● Montage van vloer zonder poten ● Installation der Boden ohne Füßen

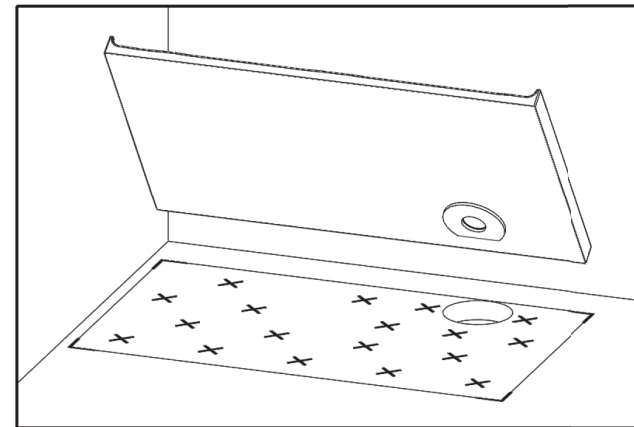

● Colle polyuréthane
 ● Polyurethane adhesive
 ● Pegamento de poliuretano
 ● Adesivo poliuretano
 ● Polyurethaan kit
 ● Polyurethan-klebstoff

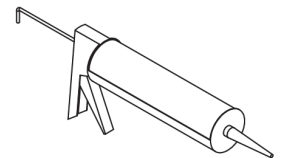

- Vérifier que tous les pieds soient bien en contact avec le sol
- Check that all feet are in contact with the floor
- Compruebe que todos los pies están en contacto con el suelo
- Controllare che tutti i piedi sono in contatto con il pavimento
- Controleer of alle voeten in contact staan met de vloer
- Prüfen, ob alle Füße sind in Kontakt mit den Boden berühren

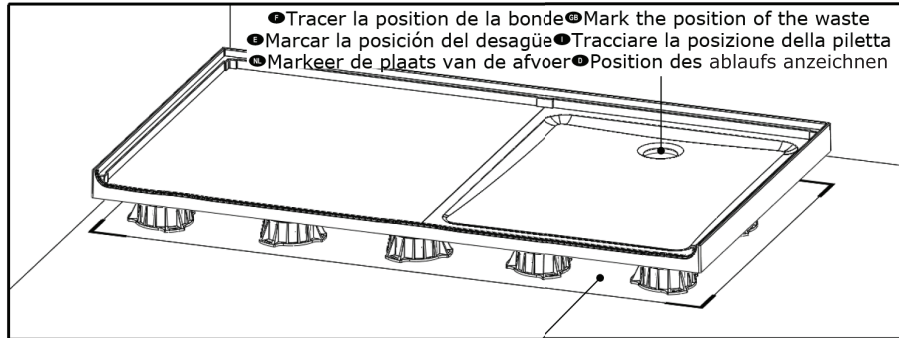

- Tracer la position de la bonde
- Mark the position of the waste
- Marcar la posición del desagüe
- Tracciare la posizione della piletta
- Markeer de plaats van de afvoer
- Position des ablaufs anzeichnen

- Sol rigide et non-humide indispensable
- Ensure a solid dry surface
- Suelo rígido y sin humedad imprescindible
- Il suolo deve essere ben asciutto e non umido
- De ondergrond moet volkomen vlak en droog zijn
- Untergrund muss fest und darf nicht feucht sein

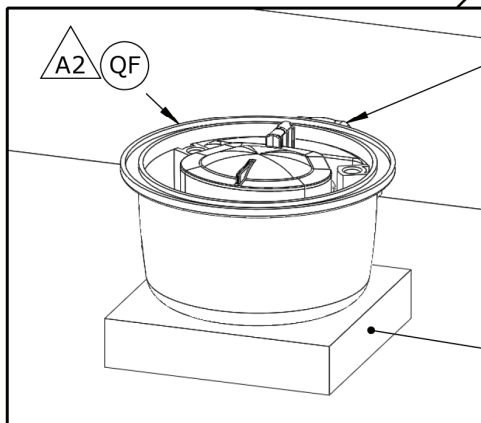
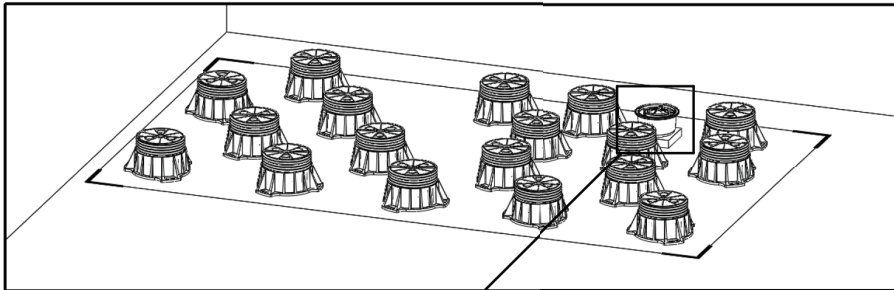

- Raccorder votre évacuation à la bonde
- Connect the waste pipe
- Conectar el tubo de evacuación al sumidero
- Collegare il tubo di evacuazione alla piletta
- Sluit de afvoer aan op het afvoerputje
- Das abflussrohr an den ablauf anschließen

- Cale en bois si nécessaire
- Provide support if necessary
- Soporte de madera en caso necesario
- Supporto in legno, se necessario
- Gebruik eventueel een houten blokje
- Ggf. holzklotz vorsehen

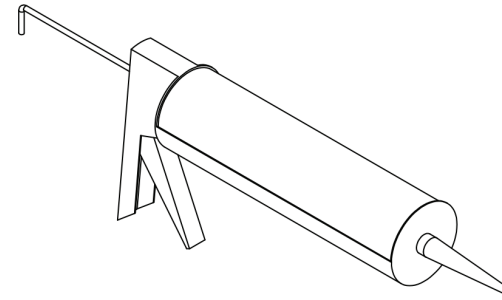

- Colle polyuréthane
- Polyurethane adhesive
- Pegamento de poliuretano
- Adesivo poliuretano
- Polyurethaan kit
- Polyurethan-klebstoff

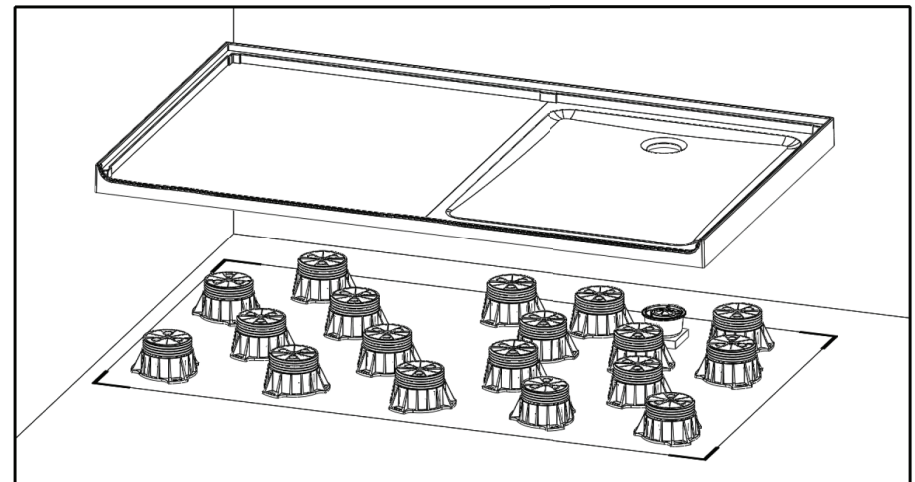
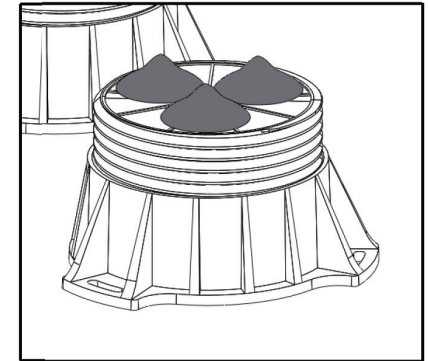

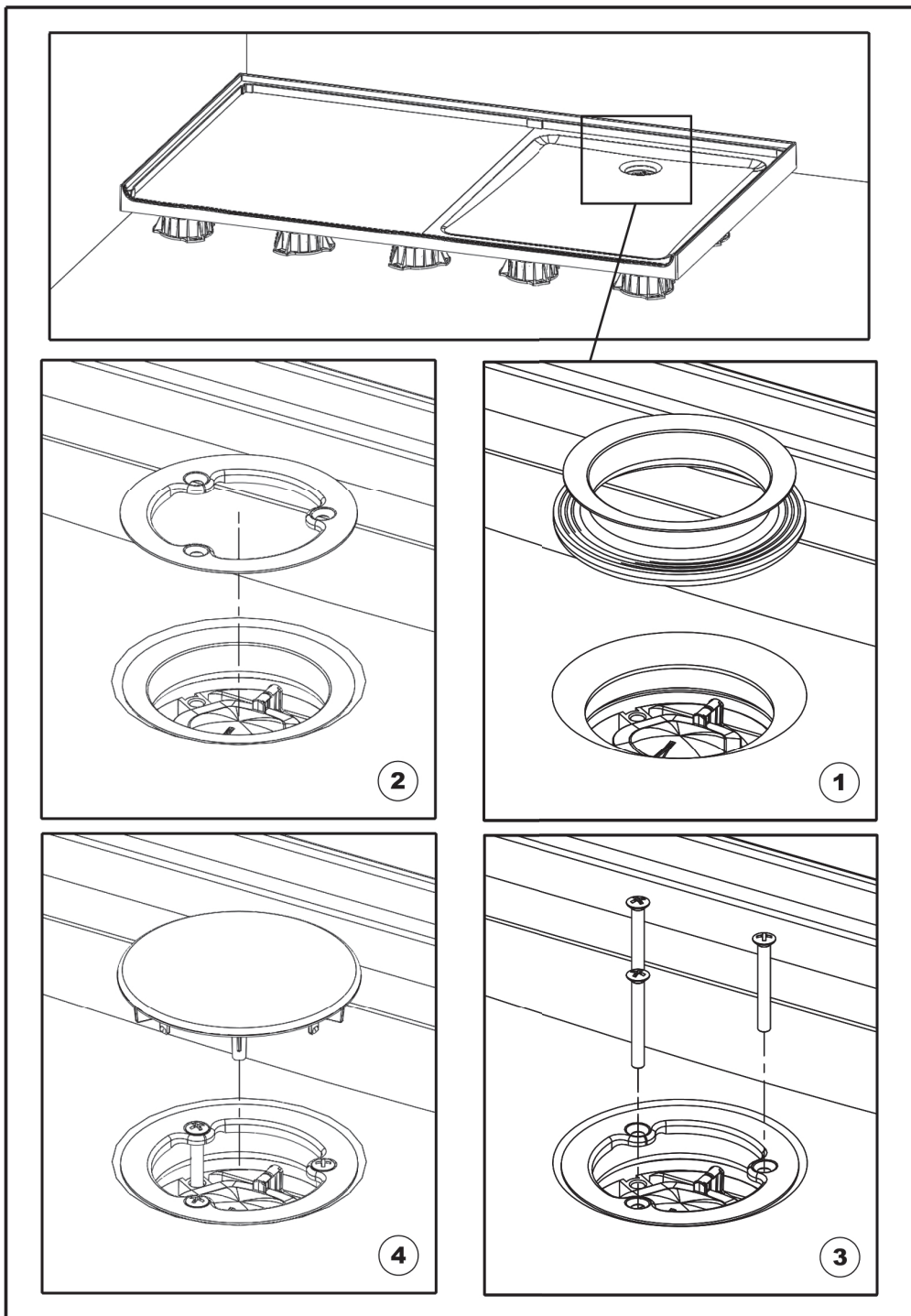

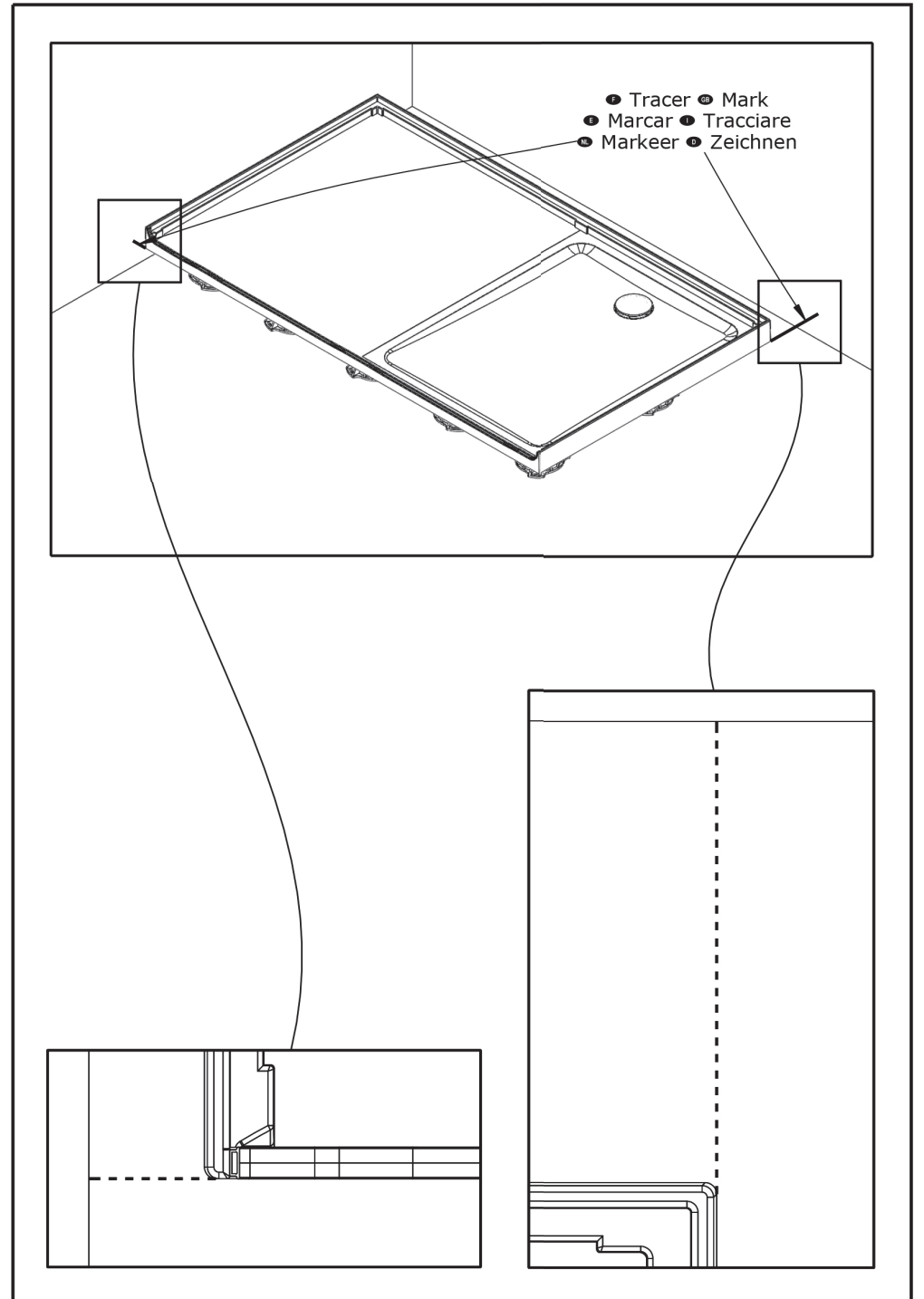
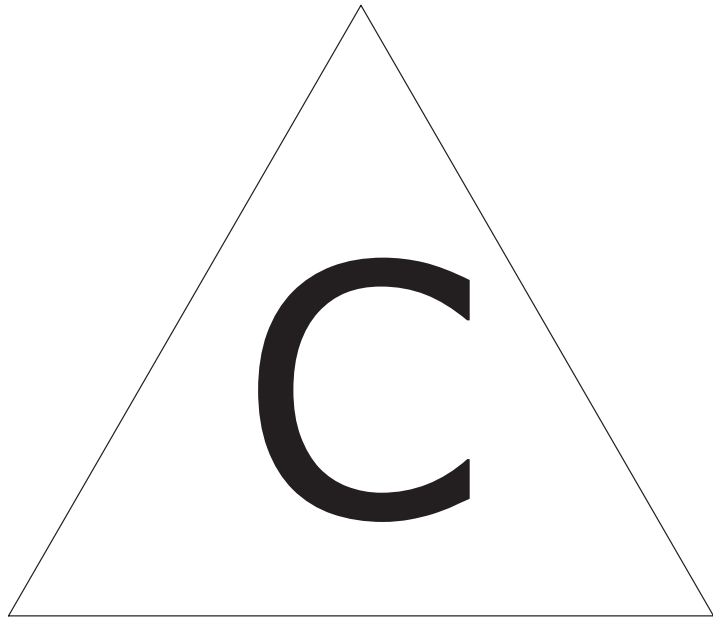

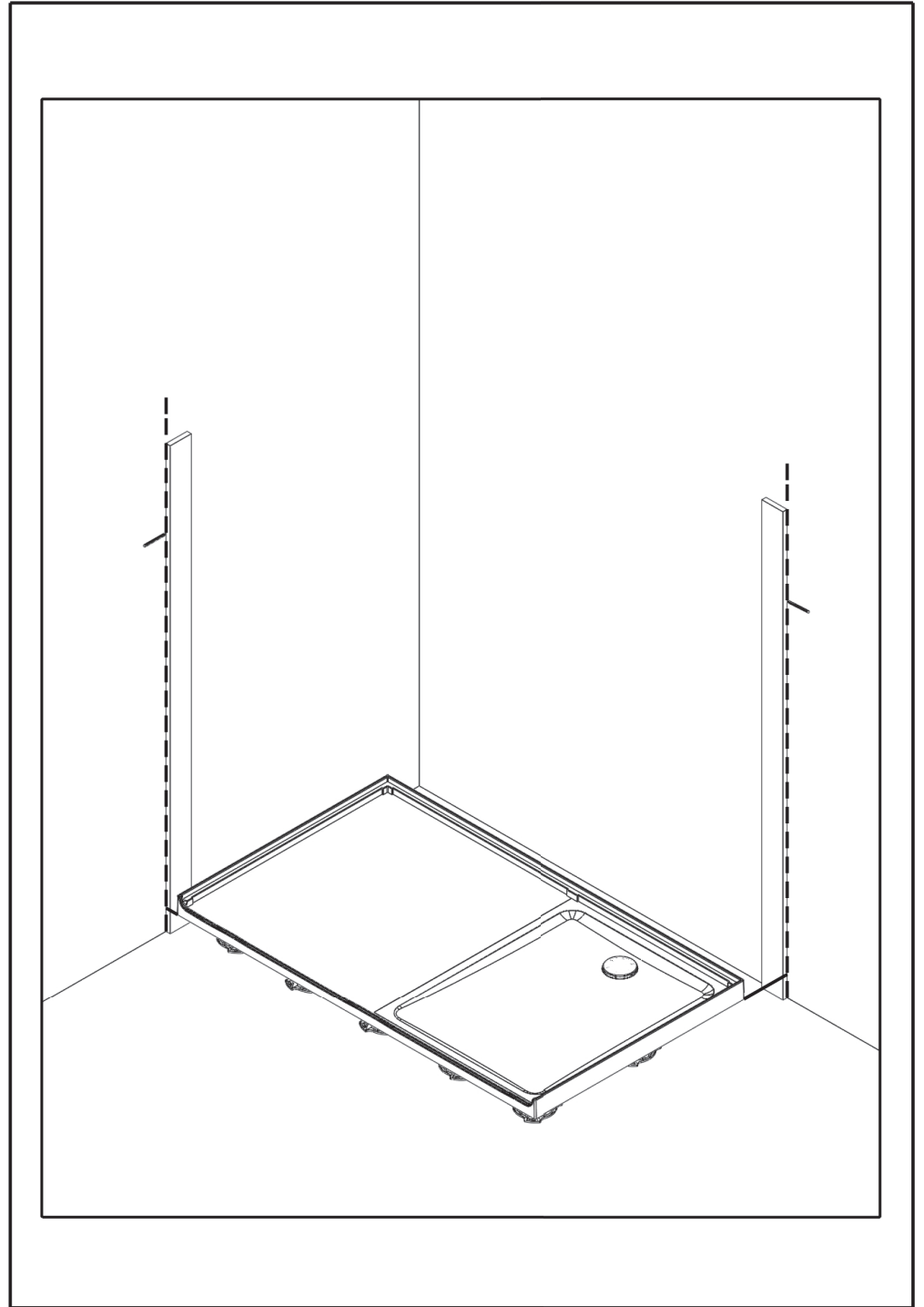
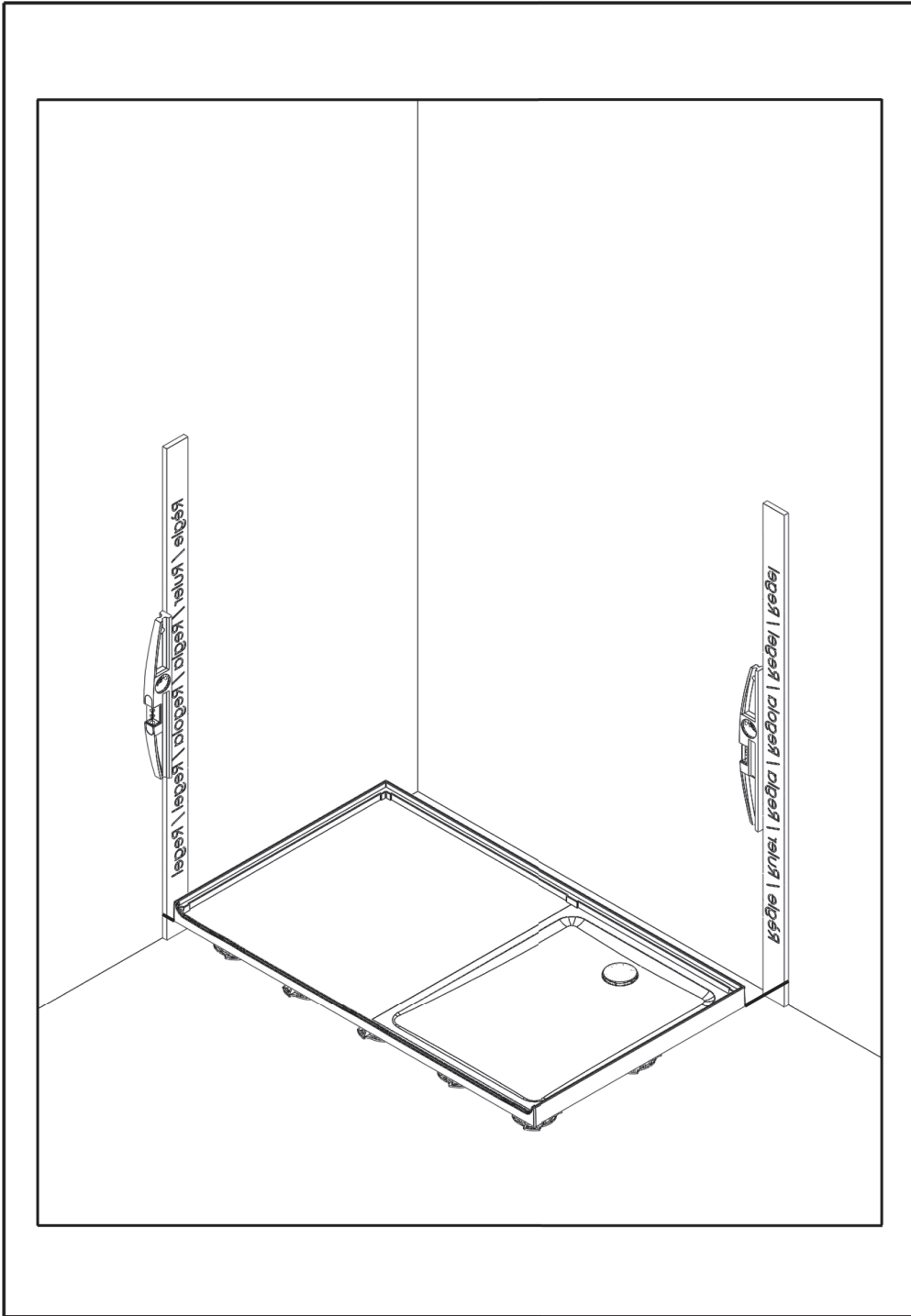

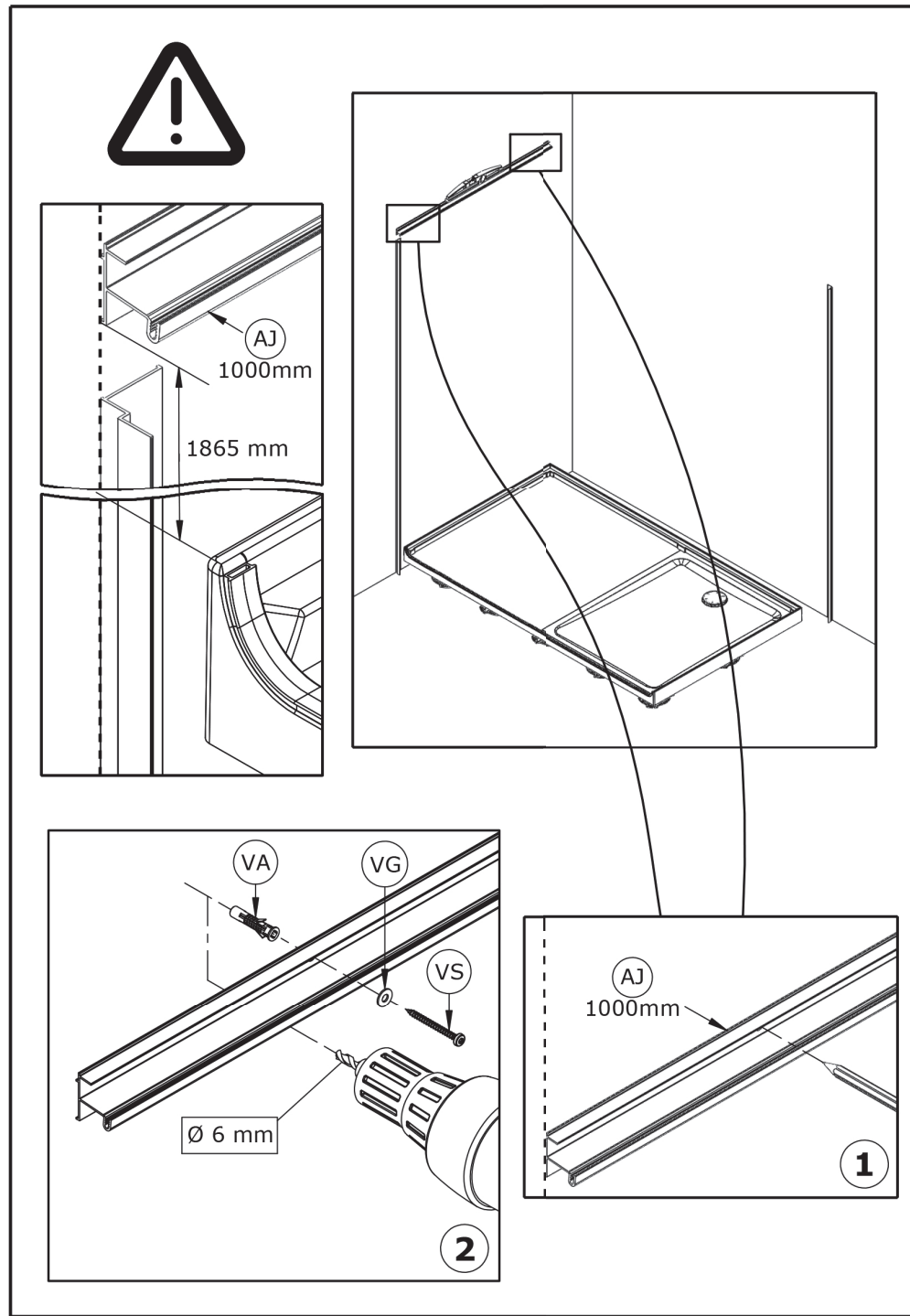
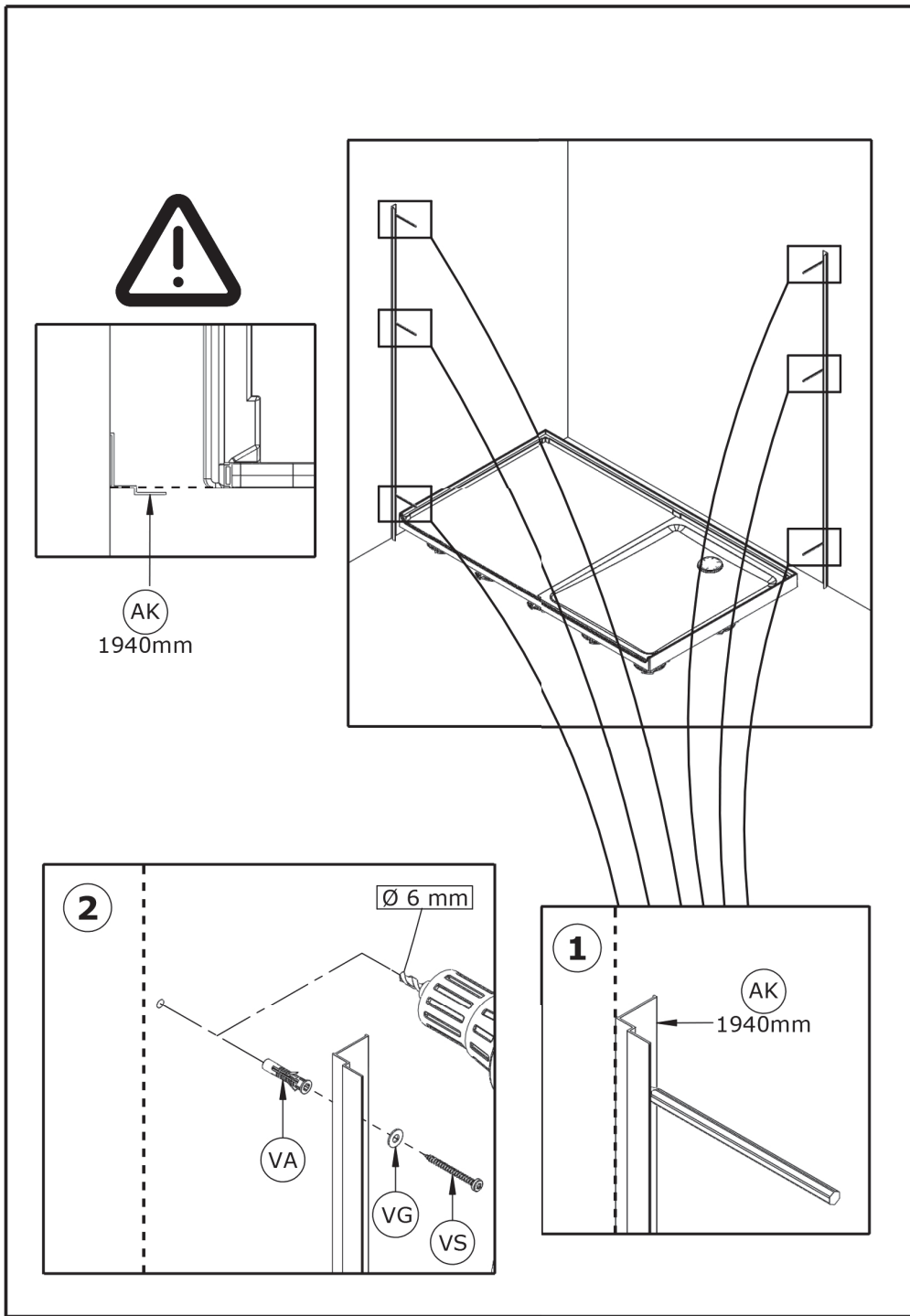

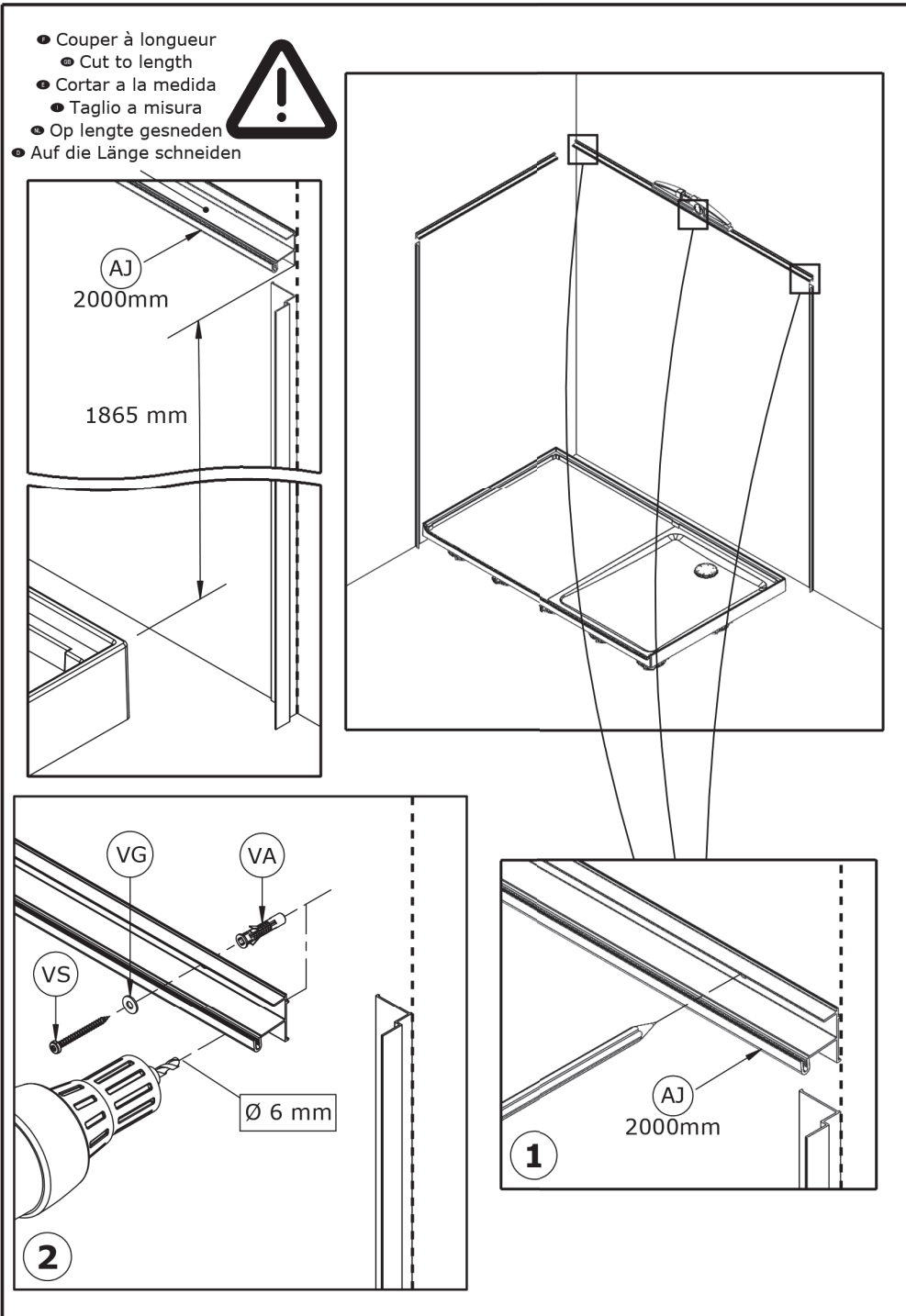

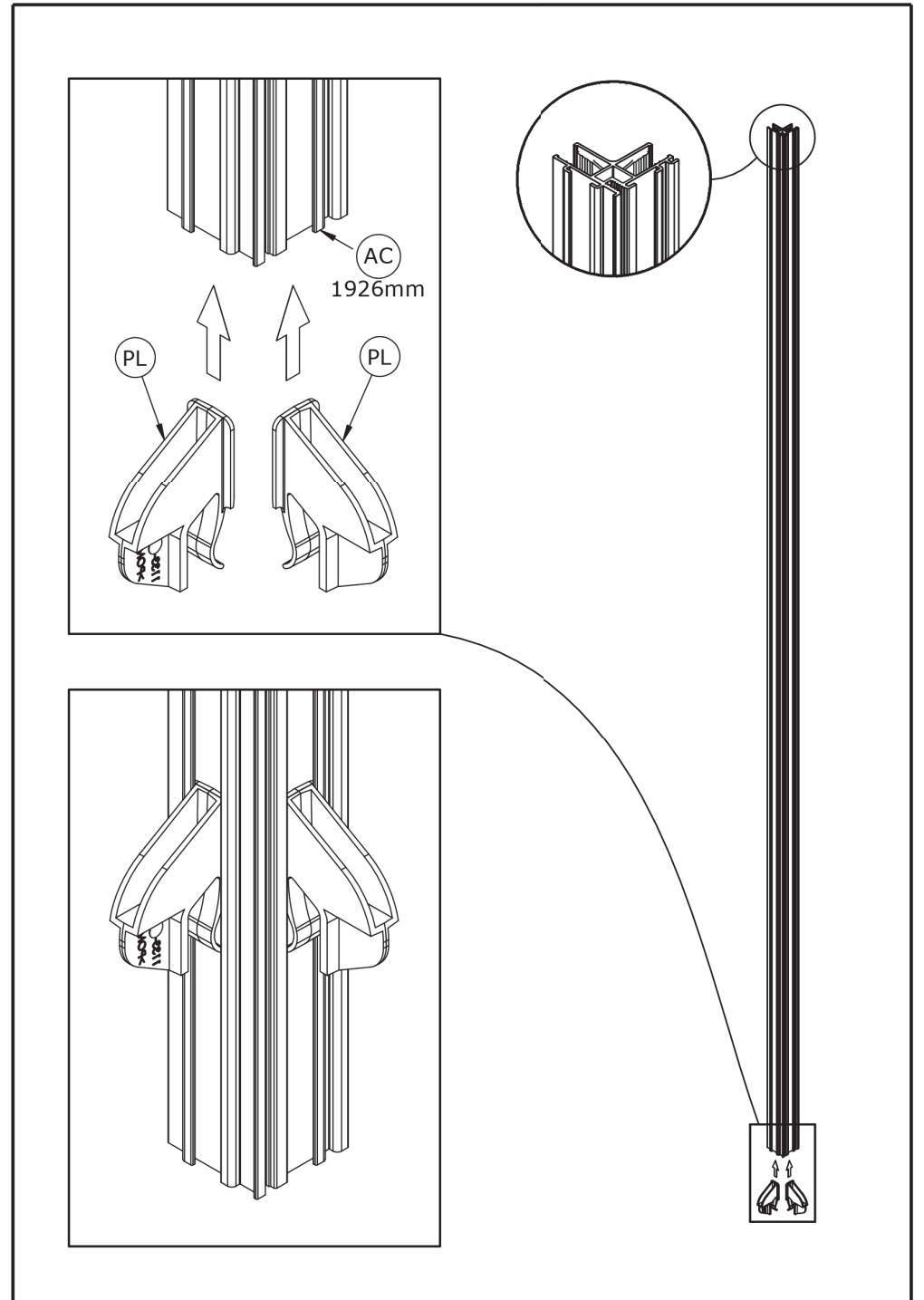
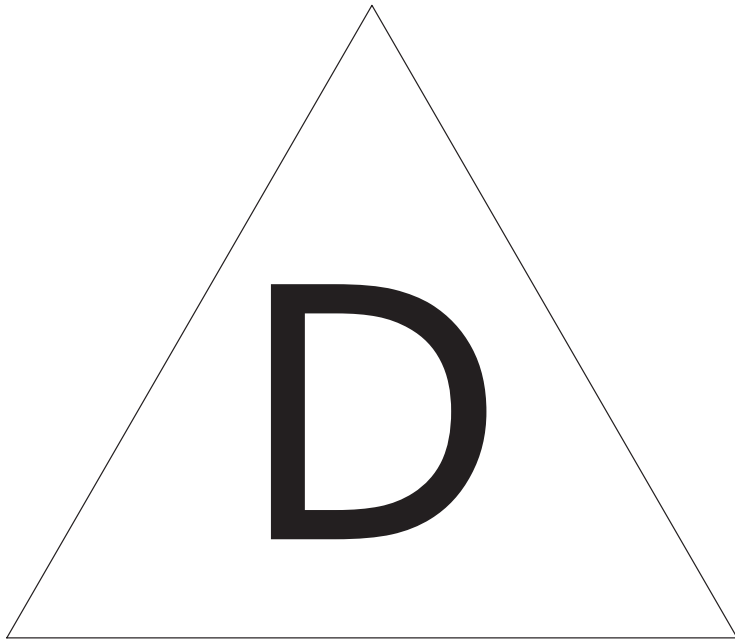

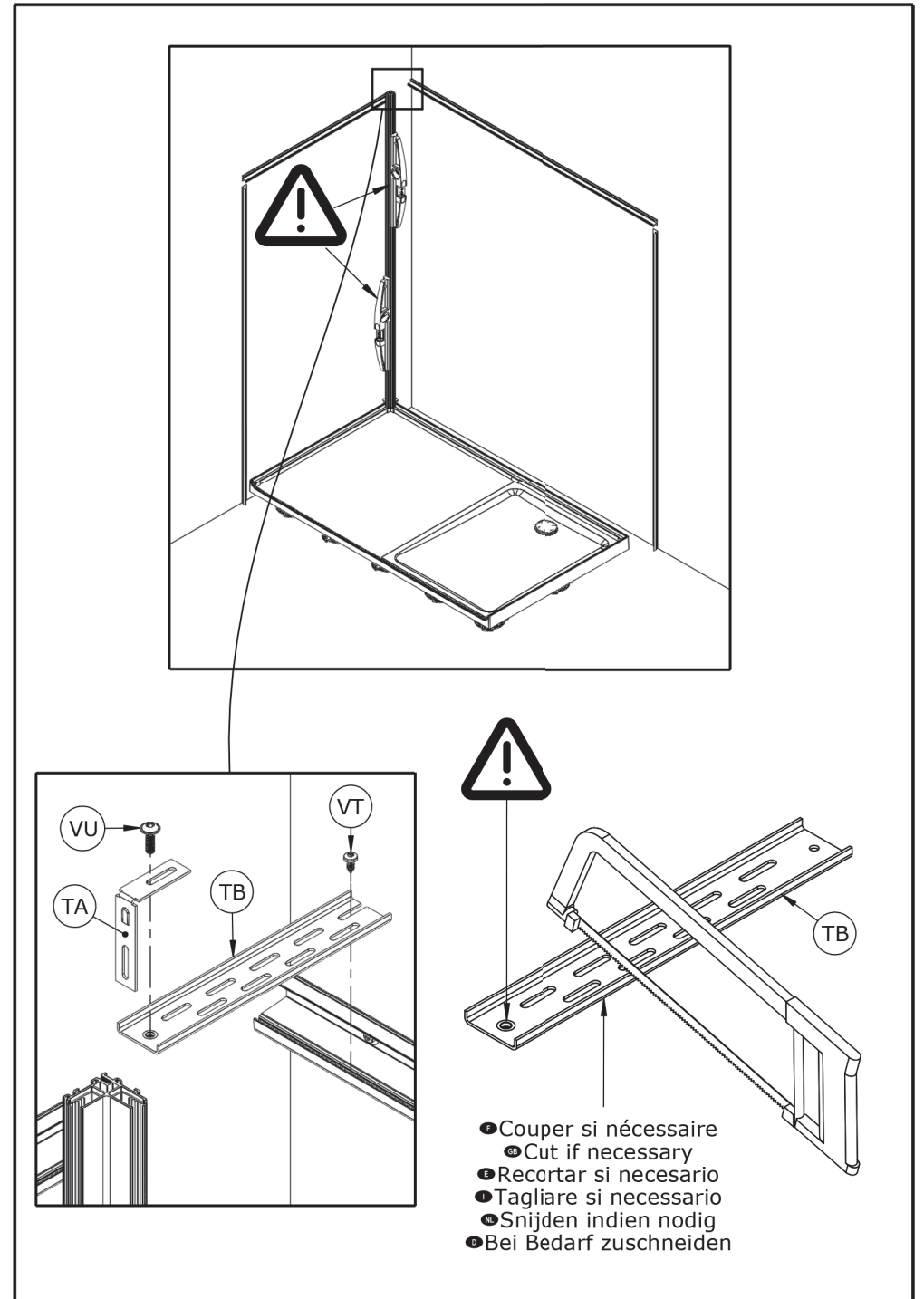
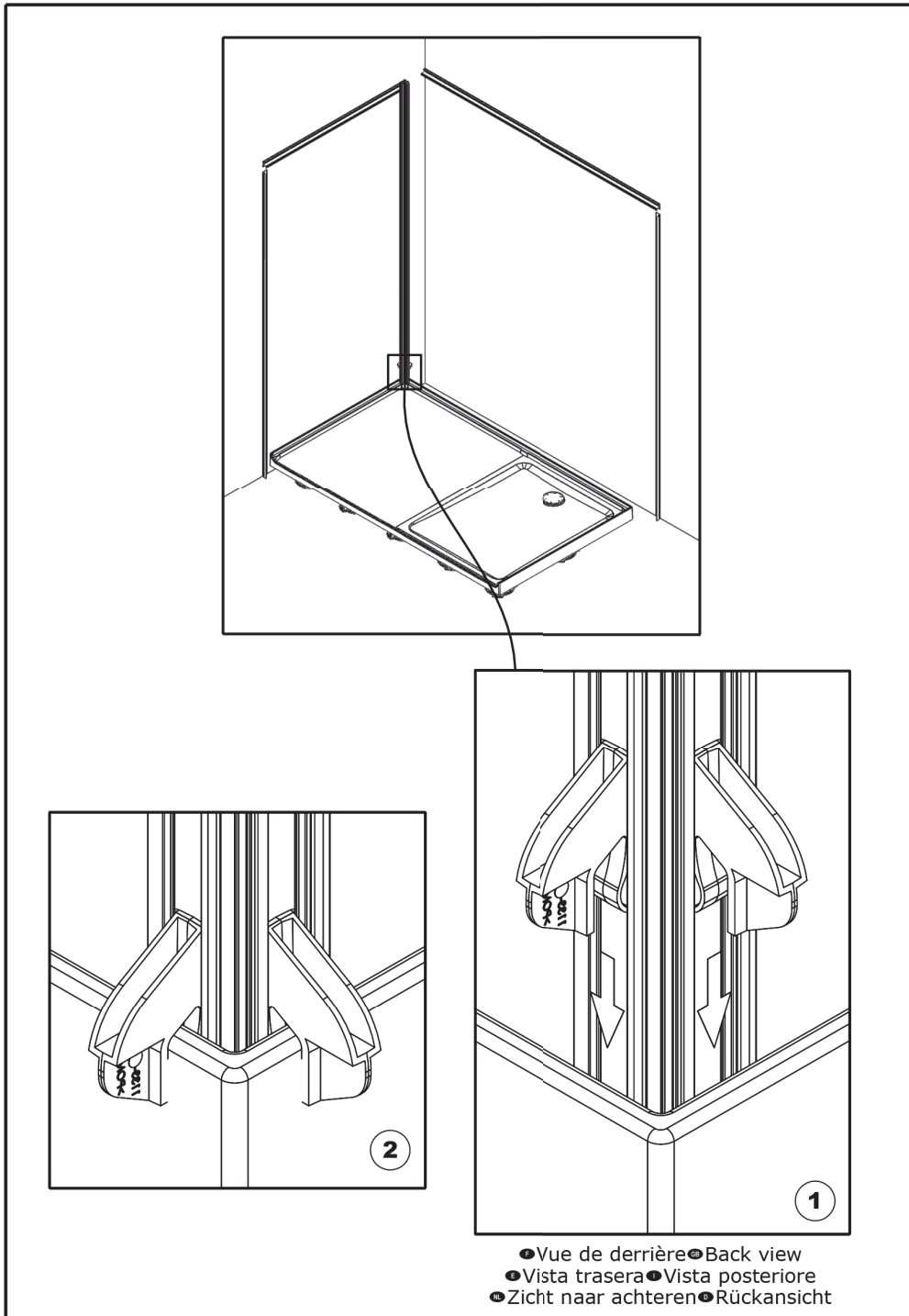

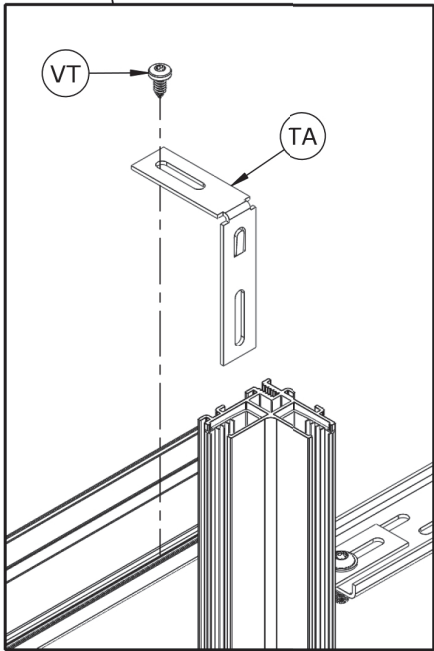
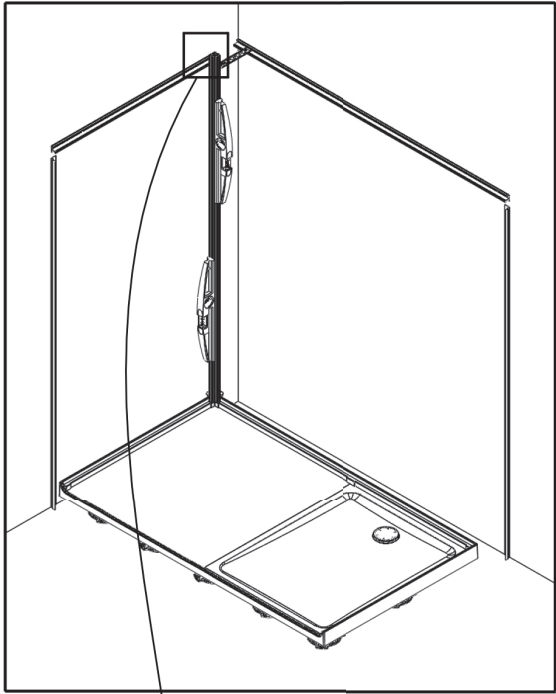

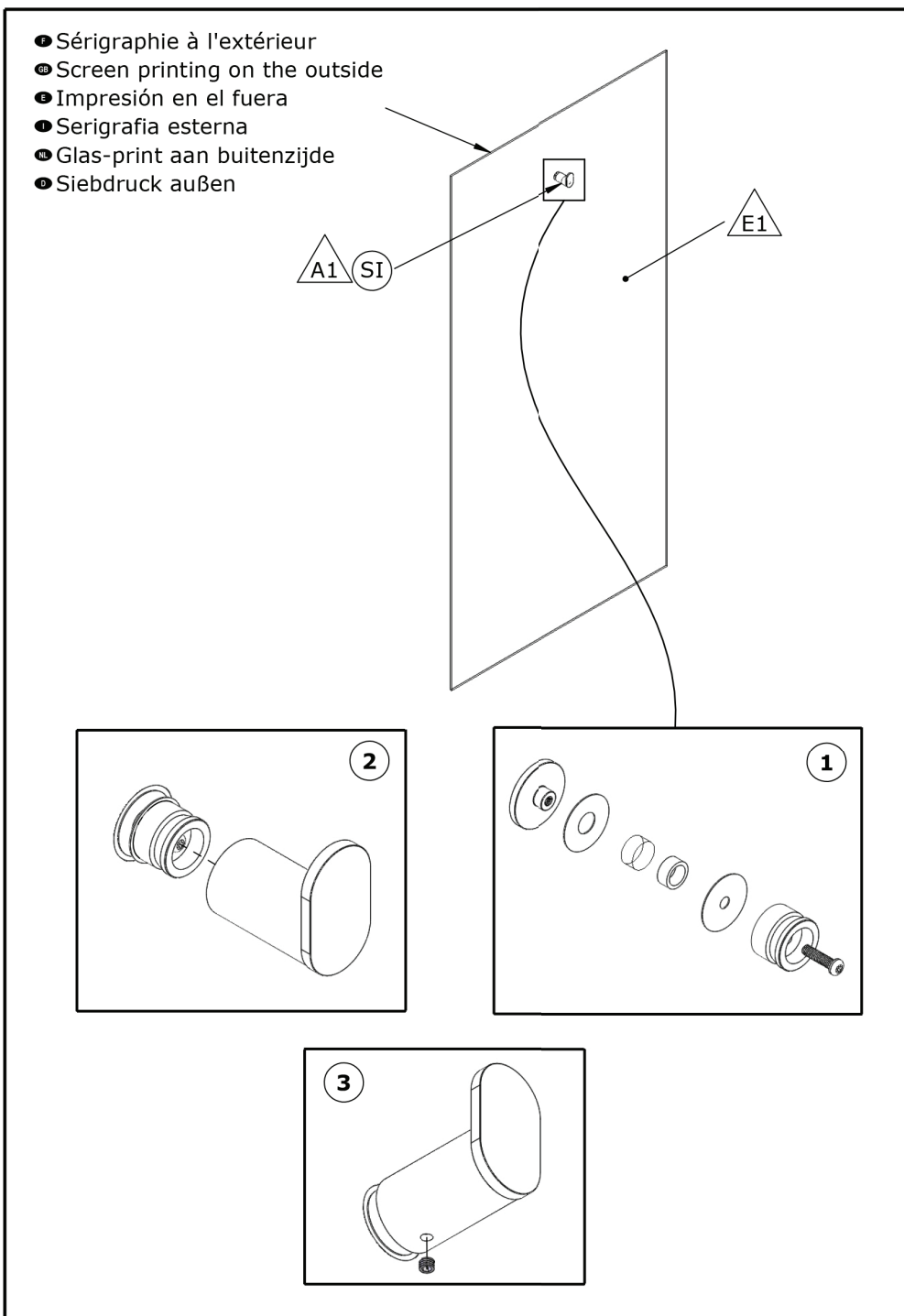

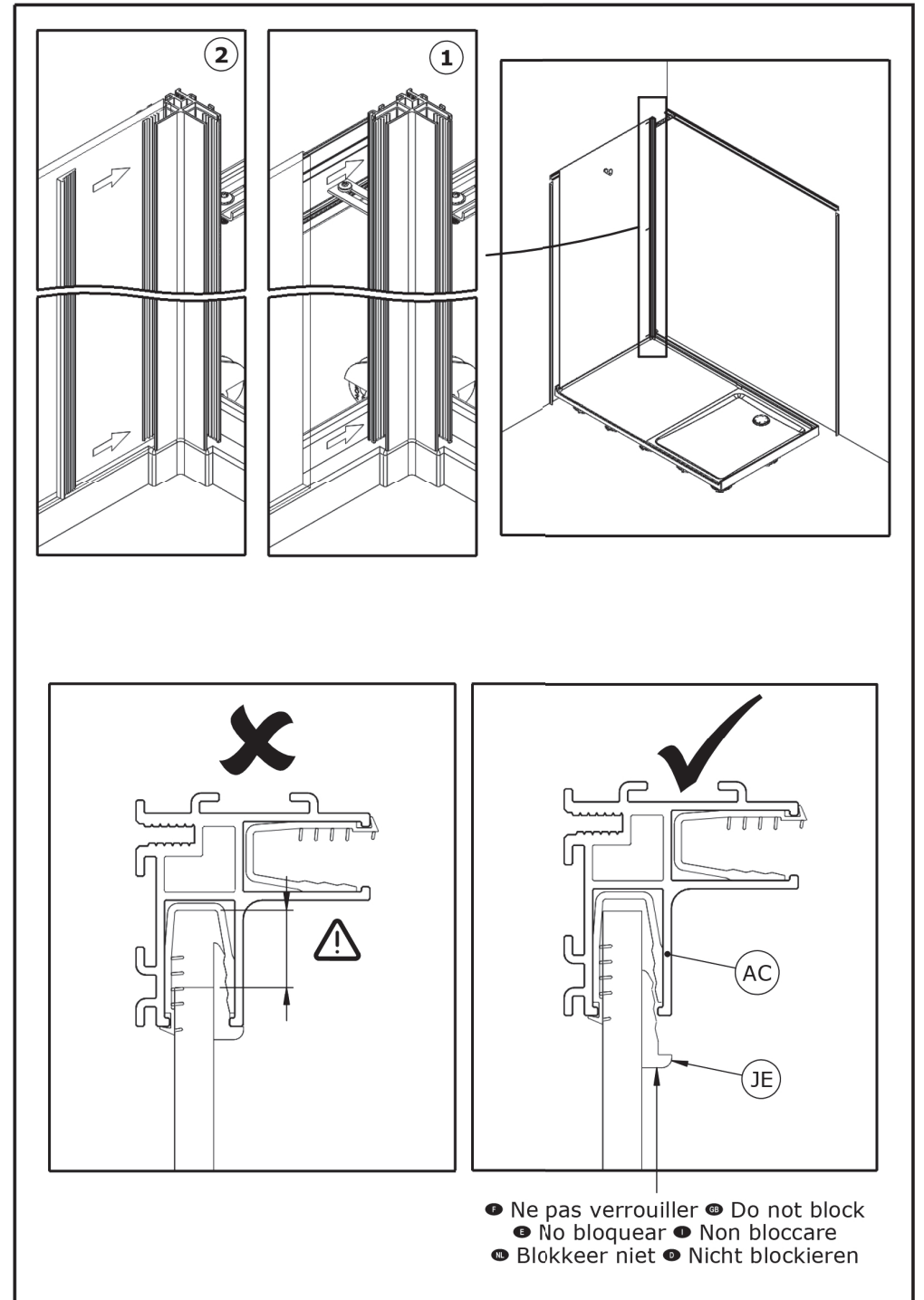
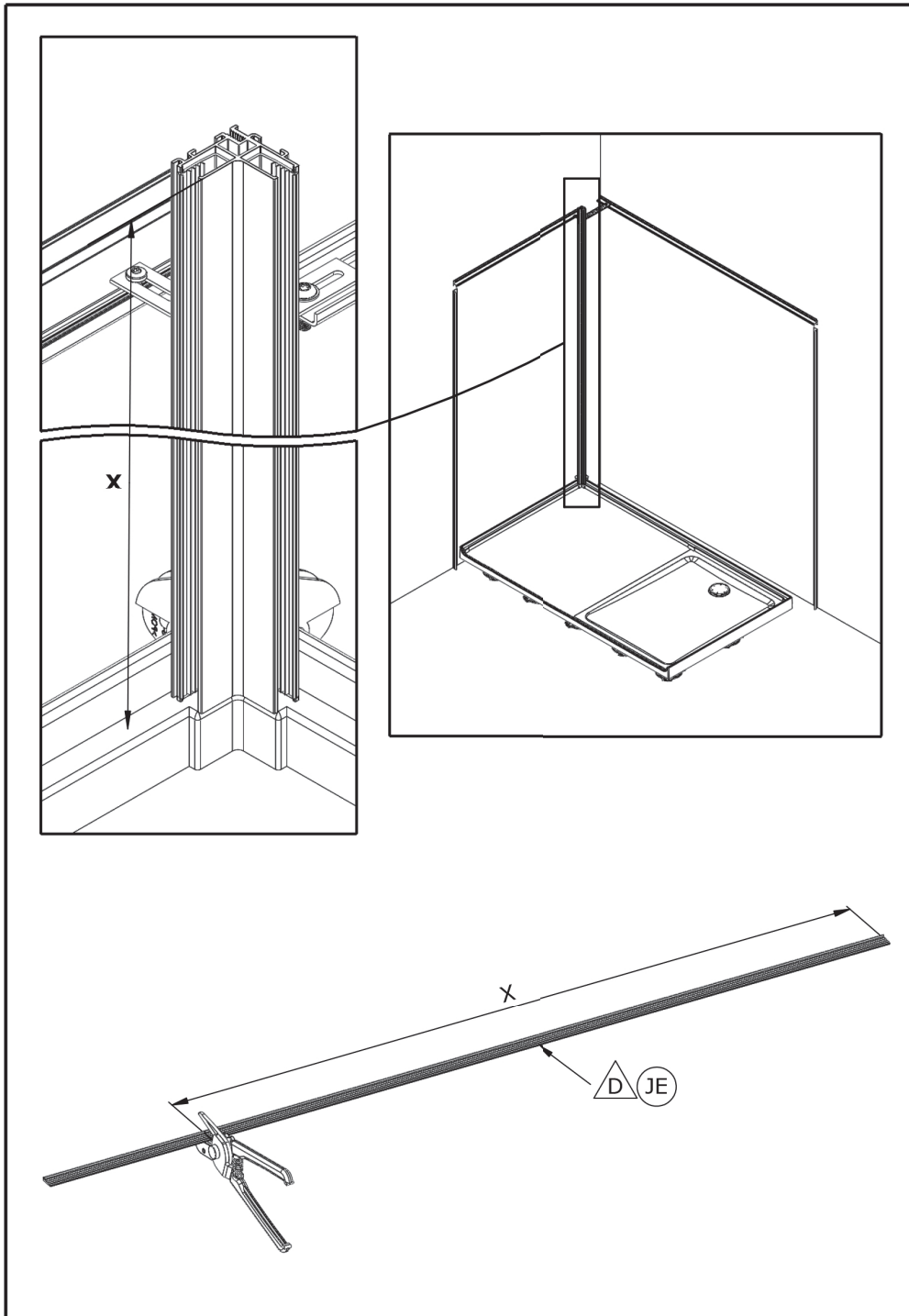

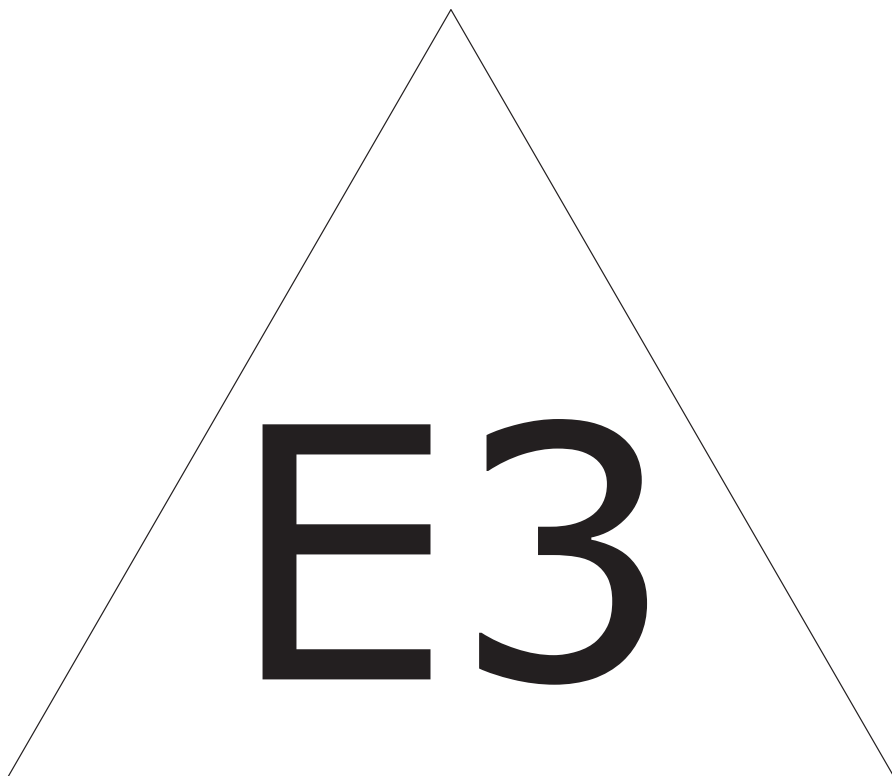

- Sérigraphie à l'extérieur
- Screen printing on the outside
- Impresión en el fuera
- Serigrafía esterna
- Glas-print aan buitenzijde
- Siebdruck außen

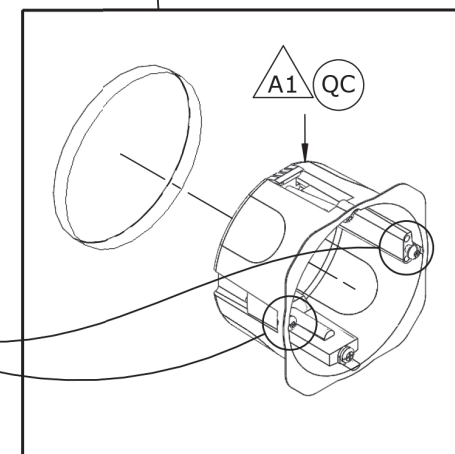
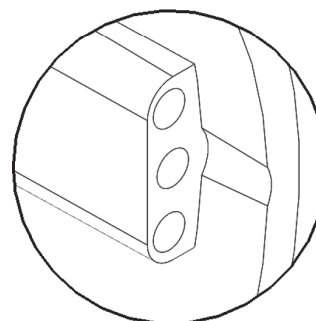
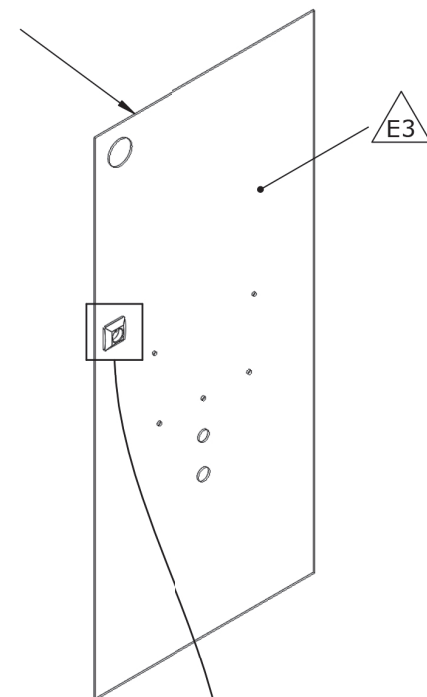

- Sérigraphie à l'extérieur
- Screen printing on the outside
- Impresión en el fuera
- Serigrafia esterna
- Glas-print aan buitenzijde
- Siebdruck außen

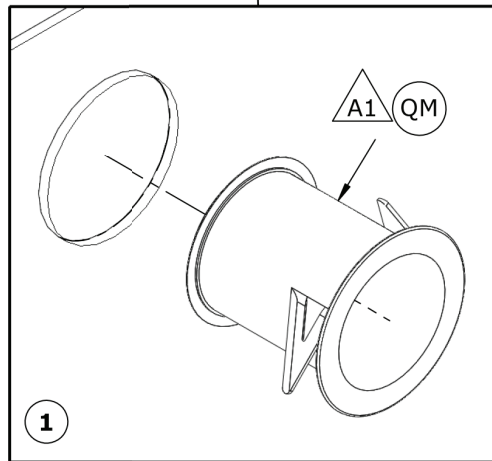
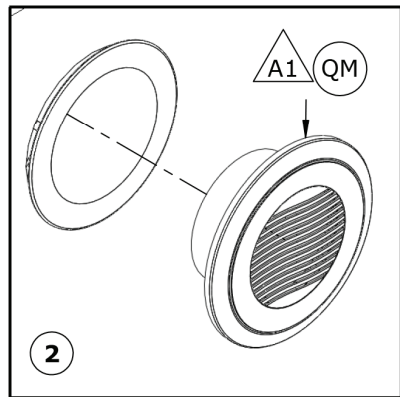
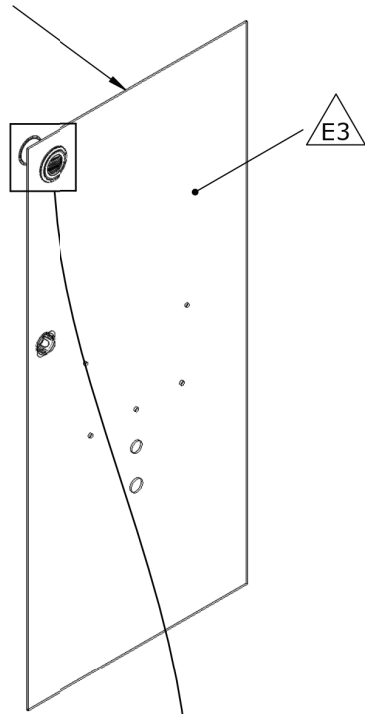

- Sérigraphie à l'extérieur
- Screen printing on the outside
- Impresión en el fuera
- Serigrafia esterna
- Glas-print aan buitenzijde
- Siebdruck außen

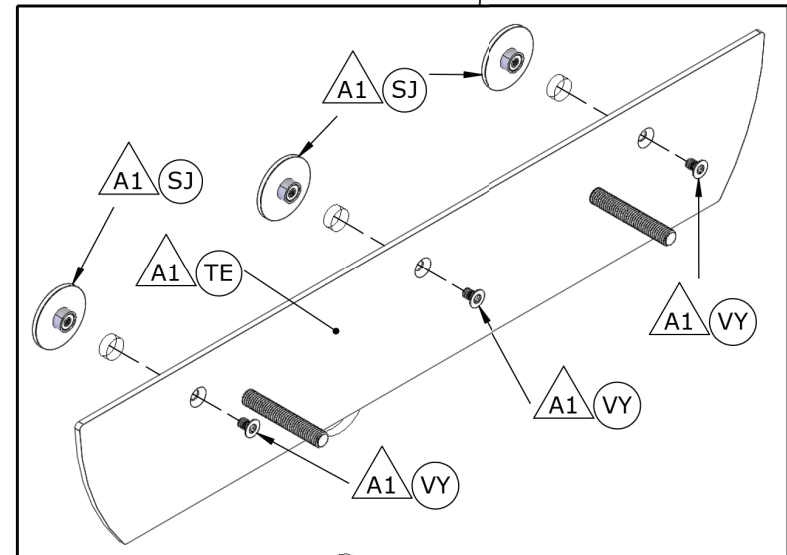
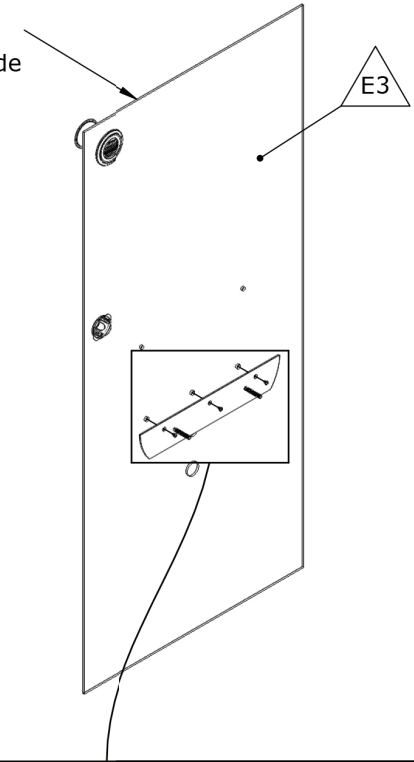

- Sérigraphie à l'extérieur
- Screen printing on the outside
- Impresión en el fuera
- Serigrafía esterna
- Glas-print aan buitenzijde
- Siebdruck außen

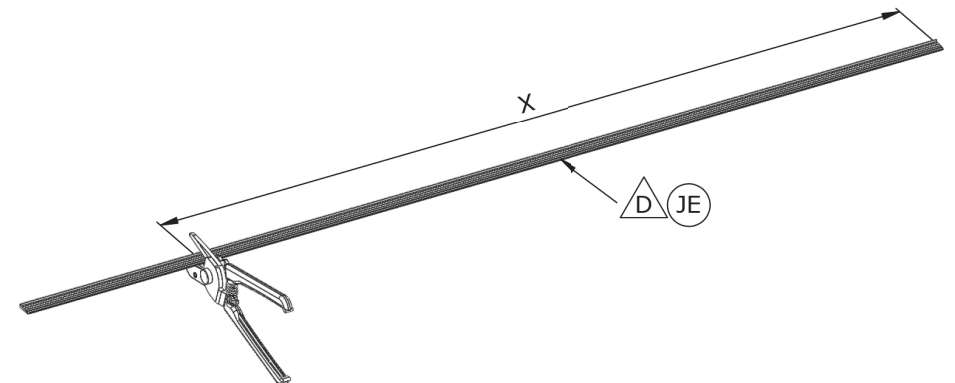
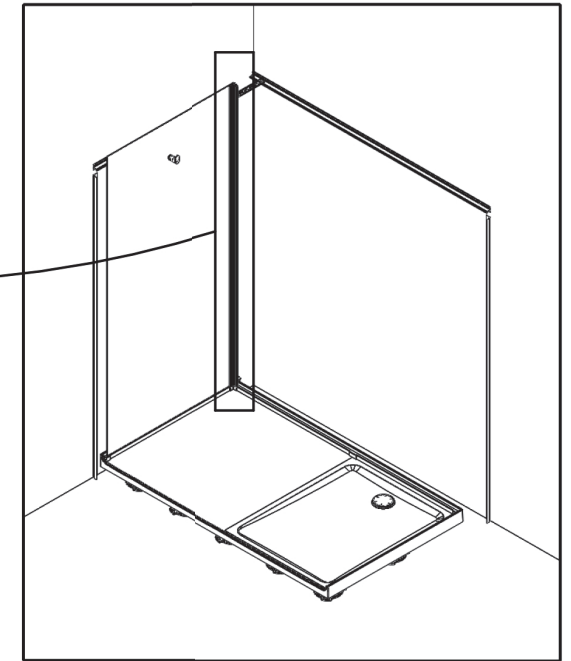
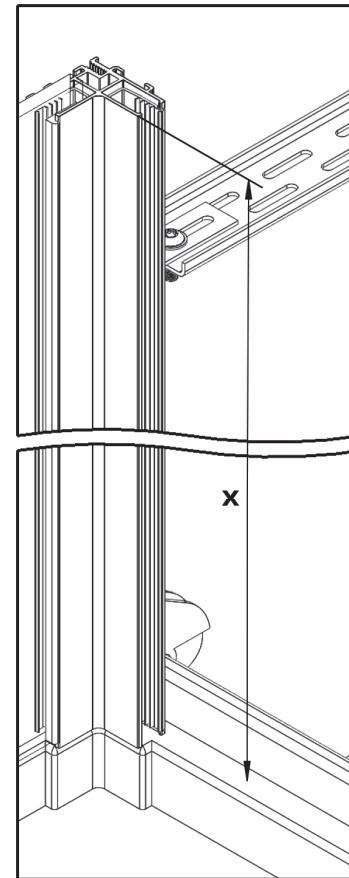
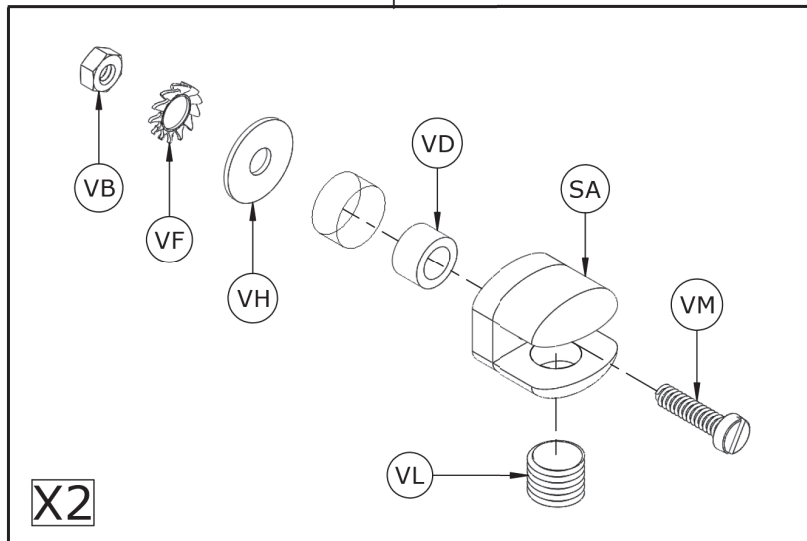
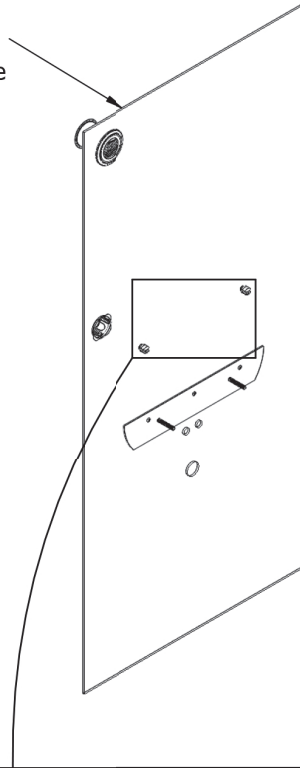

- Raccordement VMC ● VMC connection
- Conexión VMC ● Connessione VMC
- VMC-verbinding ● VMC-Verbindung

- Raccordement électrique ● Electrical connection
- Conexión eléctrica ● Connessione elettrica
- Elektrische verbinding ● Elektrische Verbindung

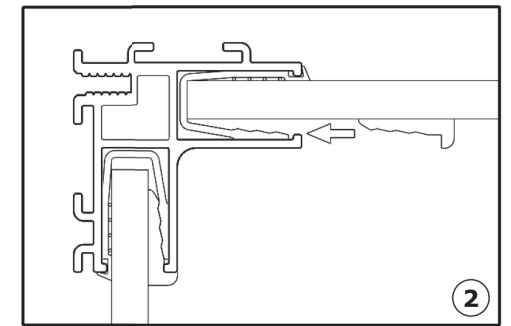
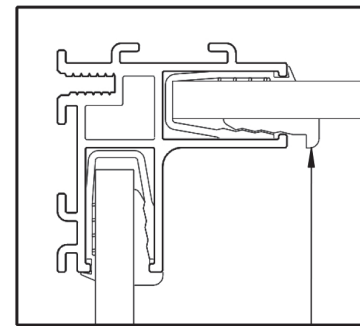
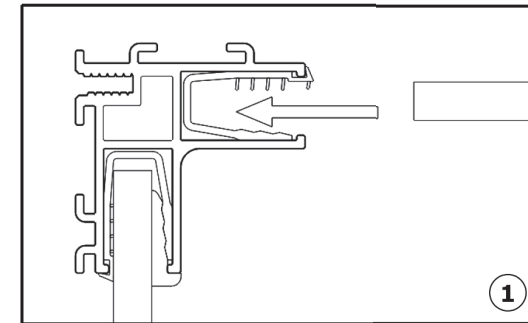
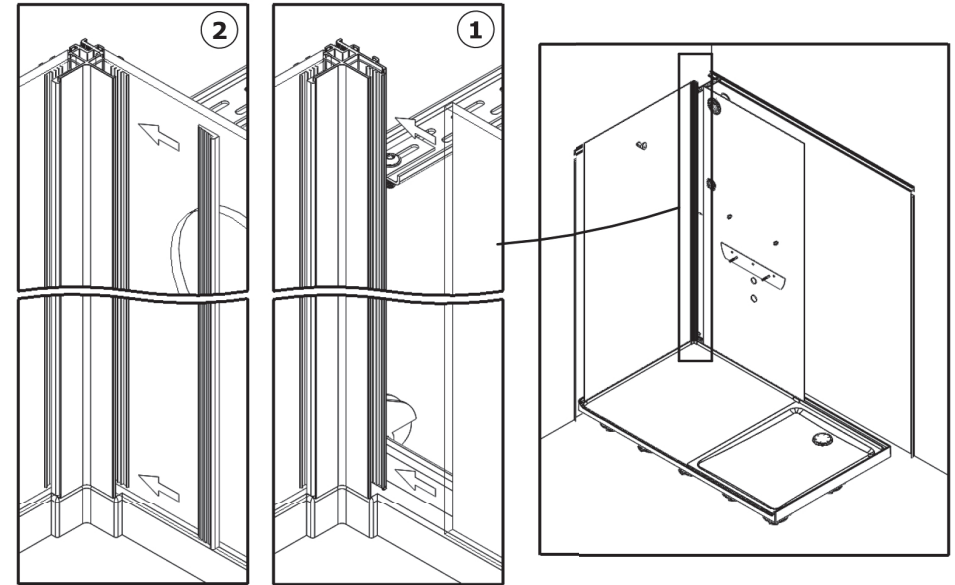
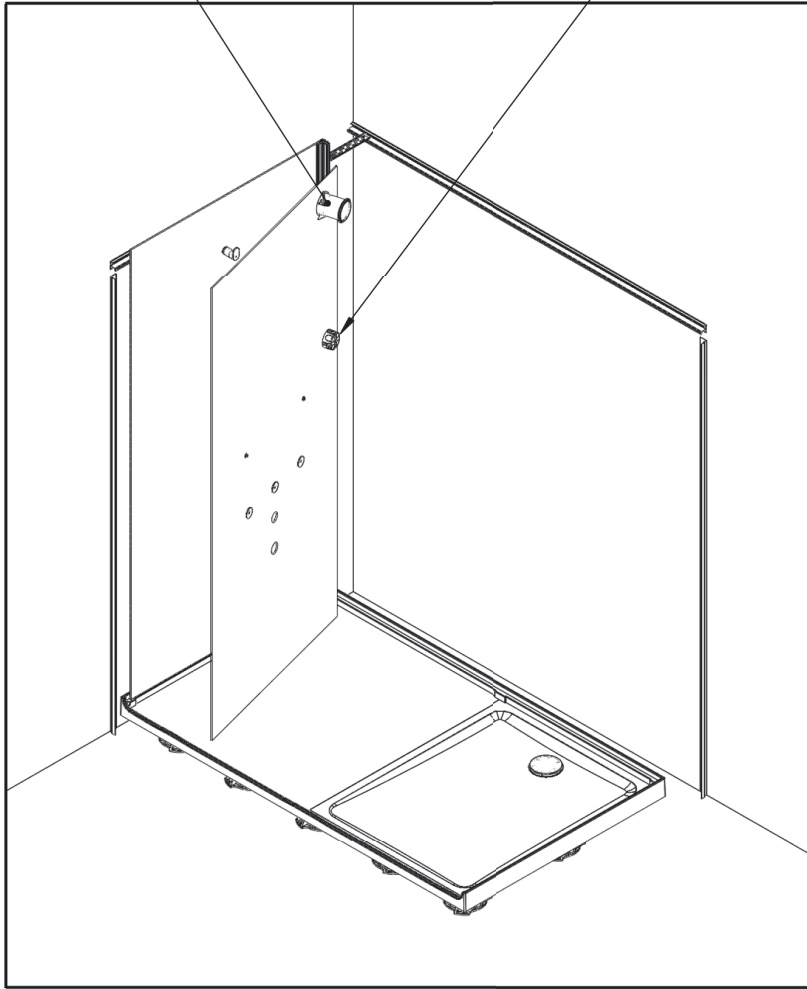

- Ne pas verrouiller ● Do not block
- No bloquear ● Non bloccare
- Blokkeer niet ● Nicht blockieren

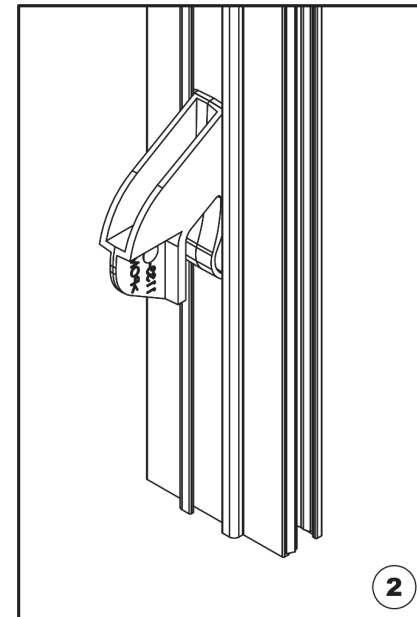
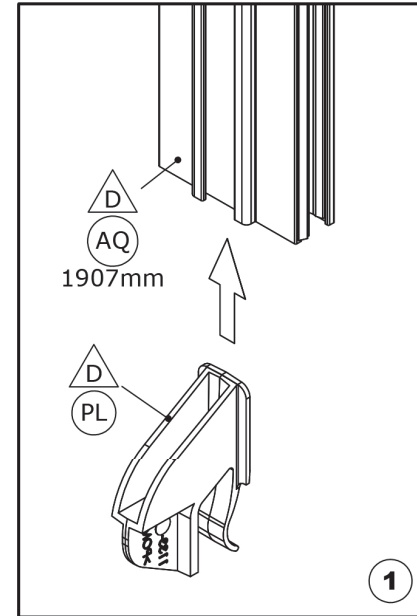
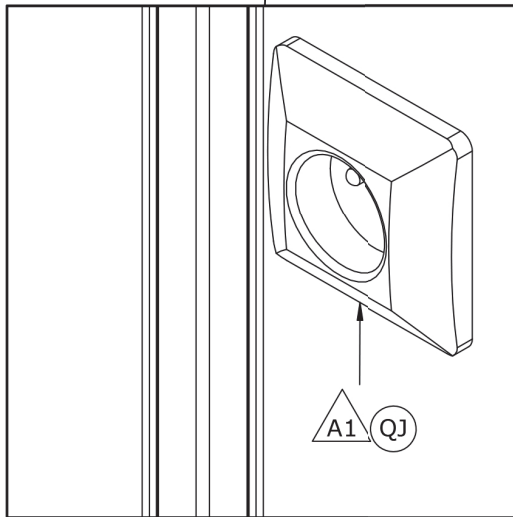
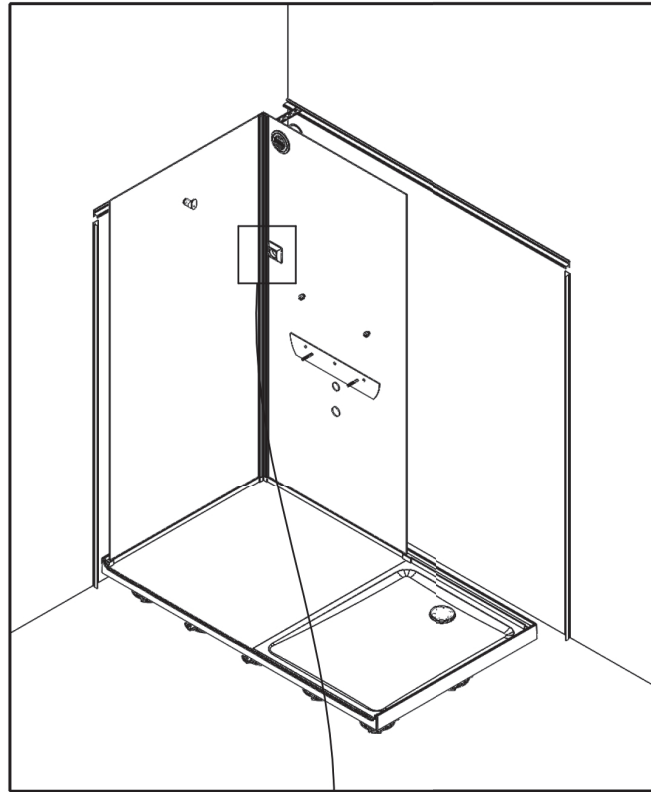

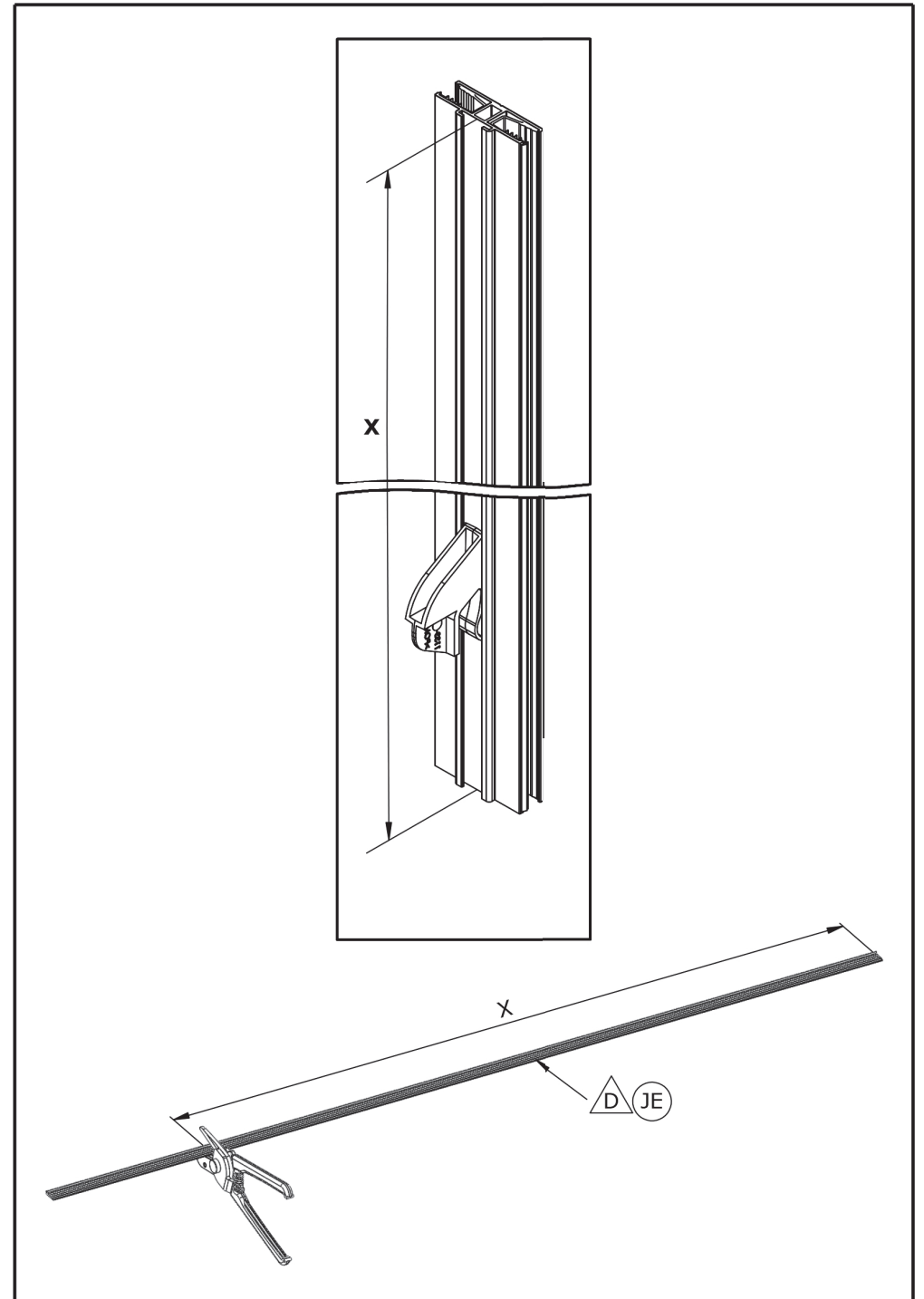
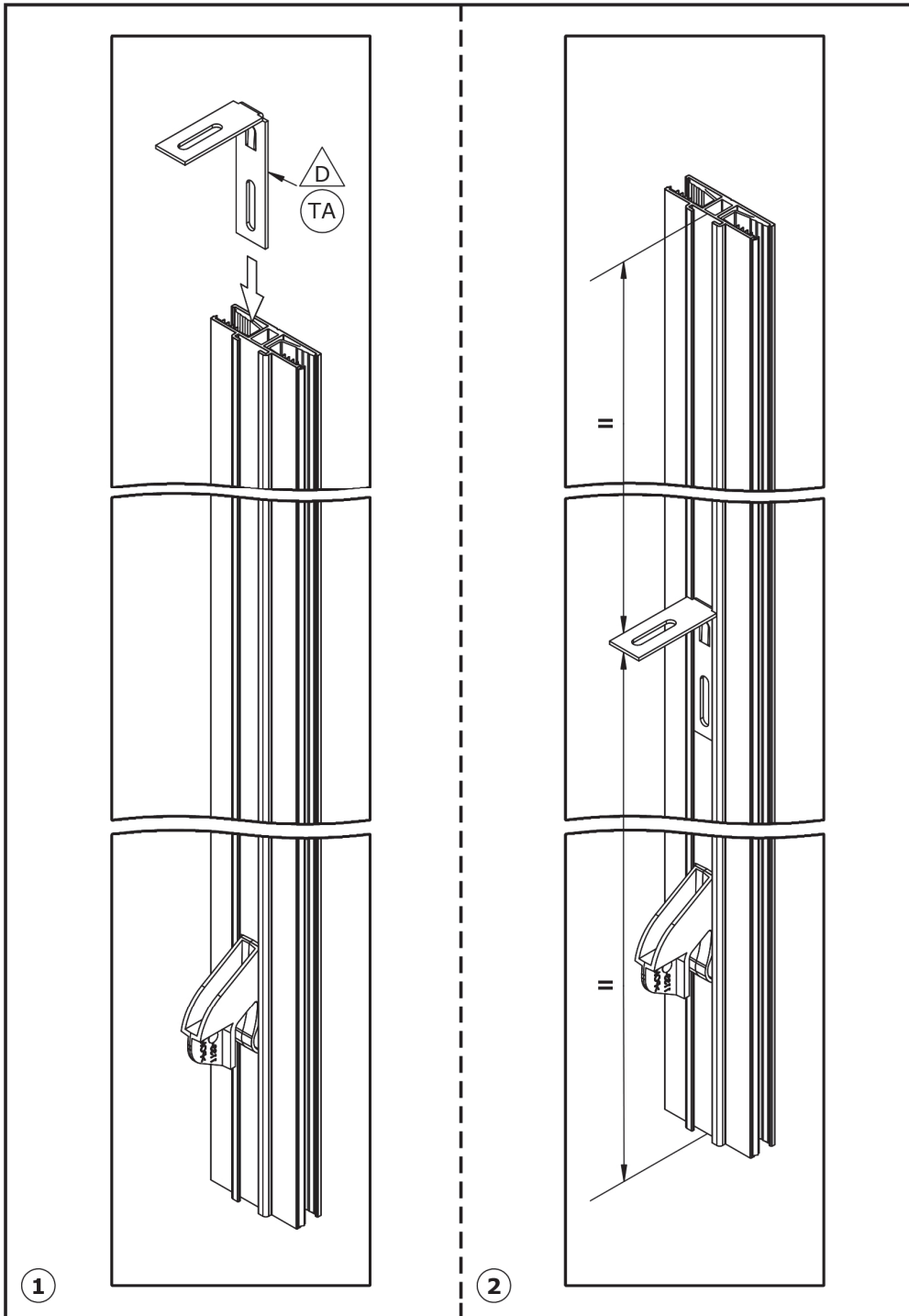

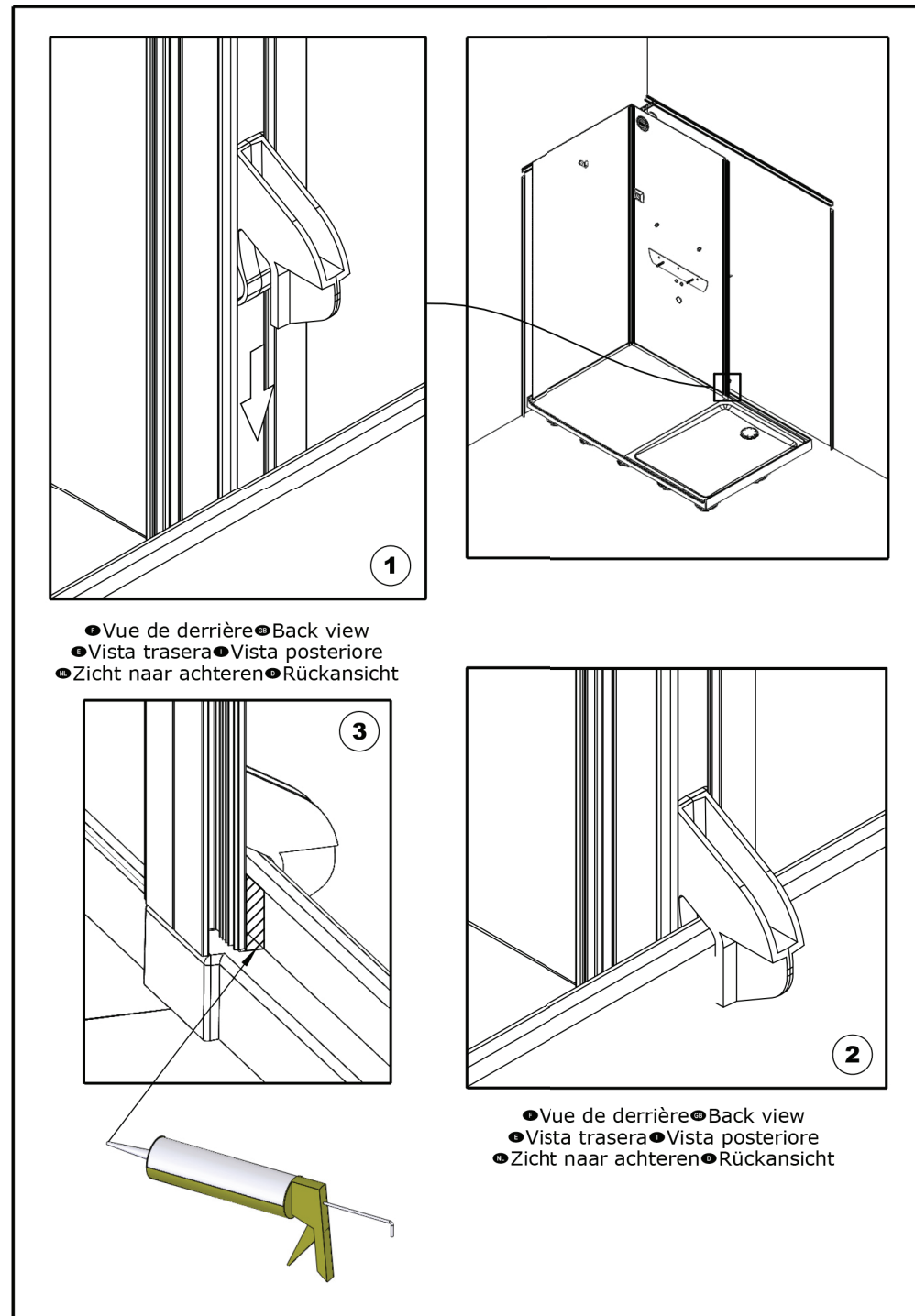
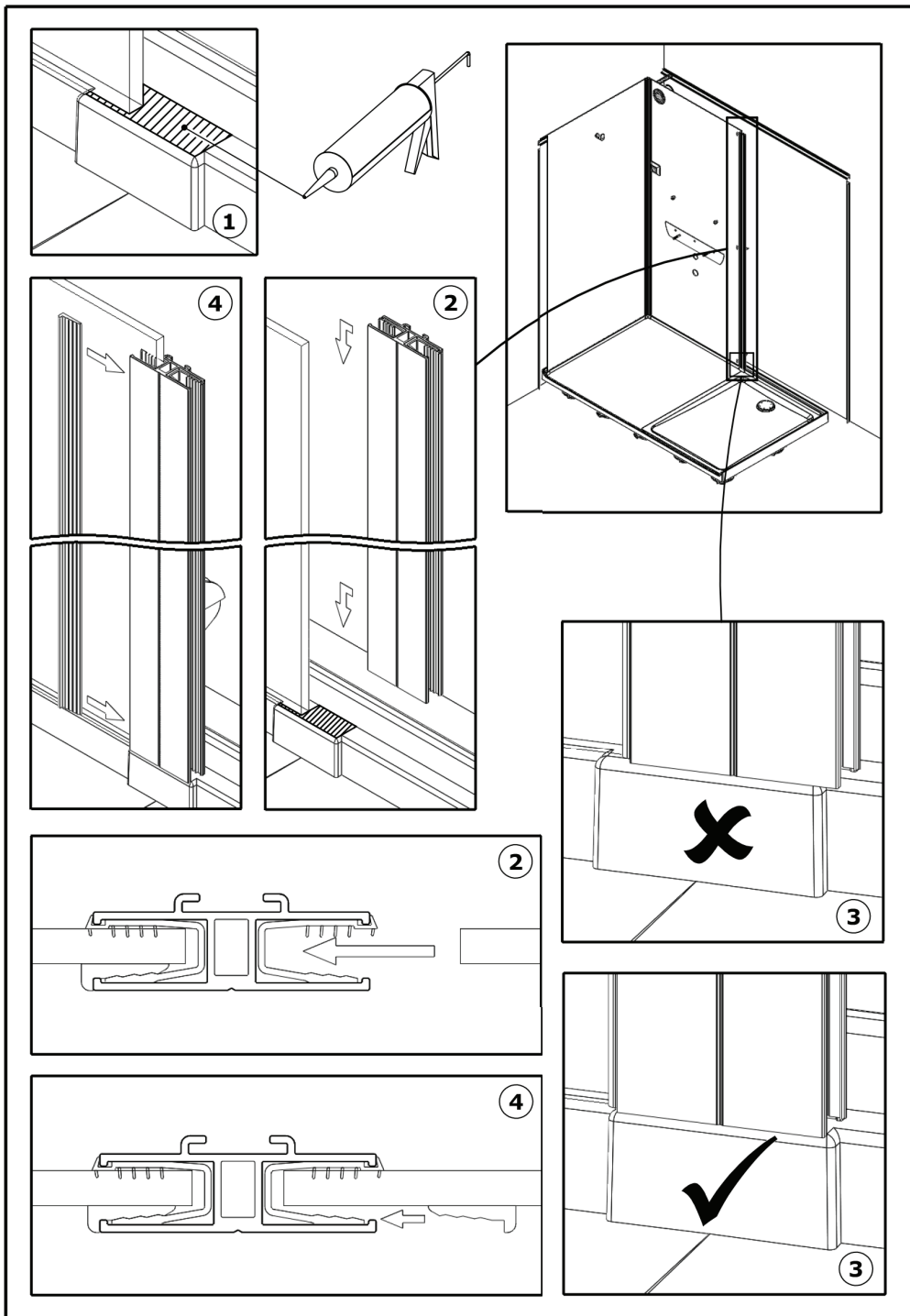

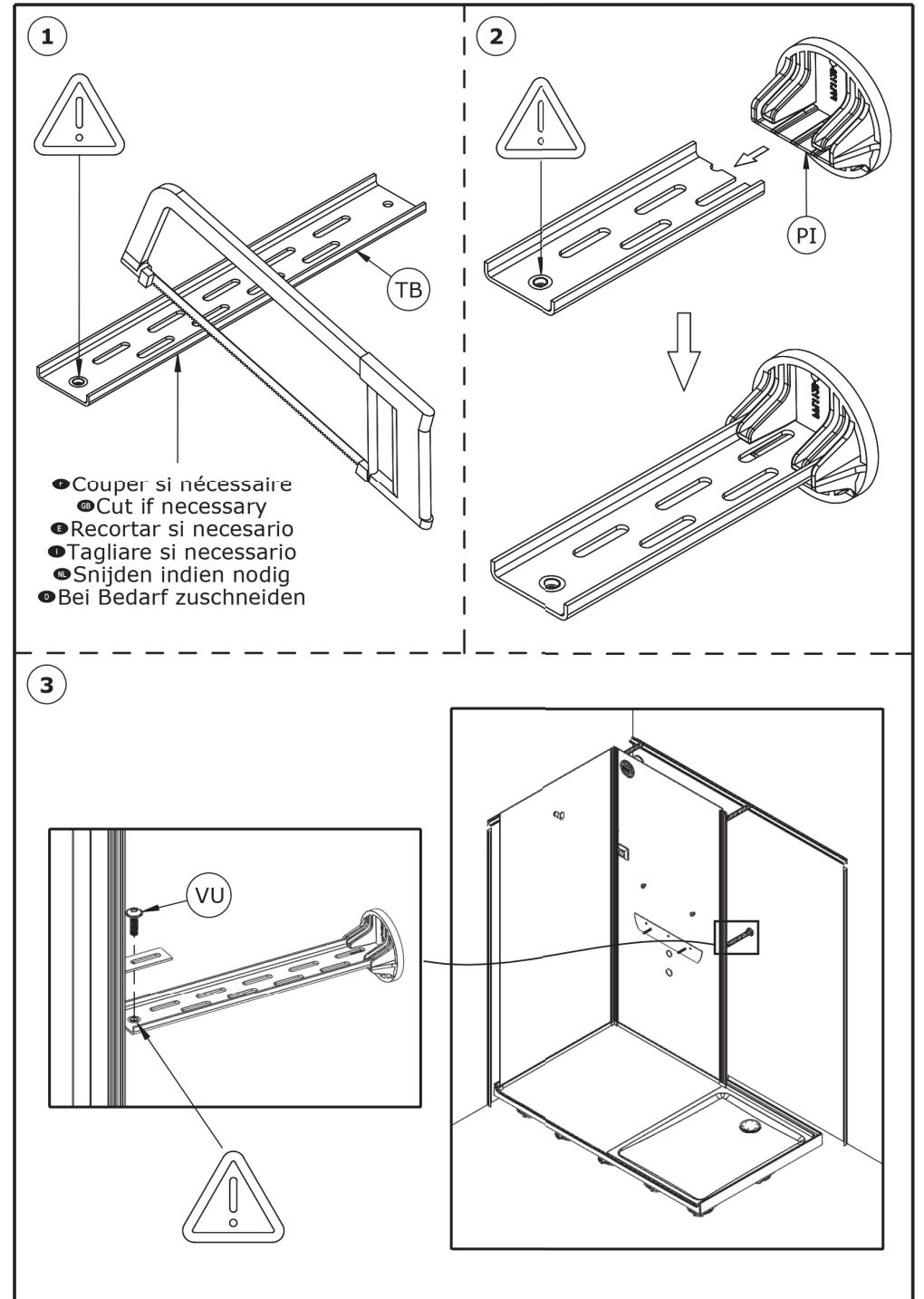
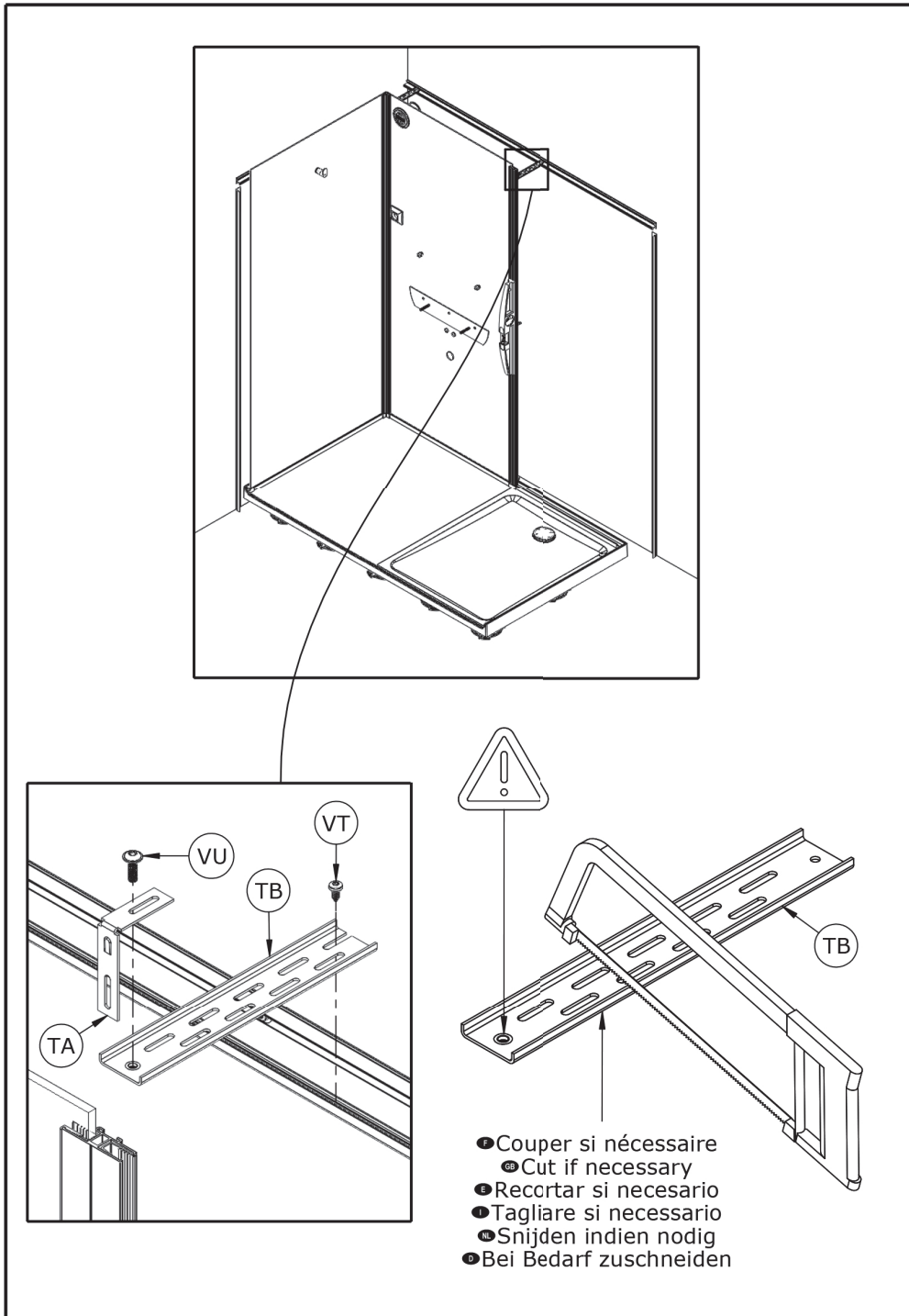

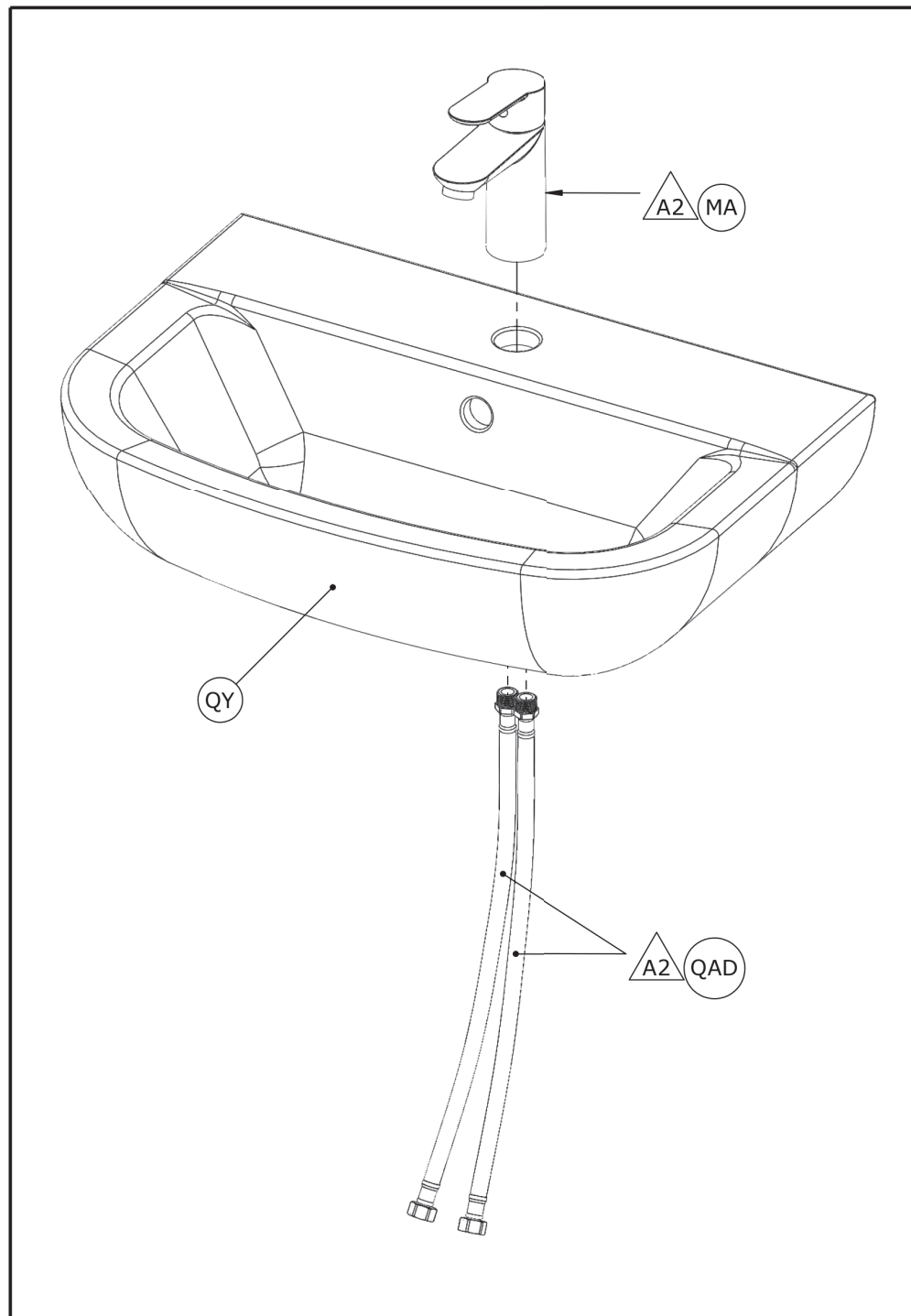
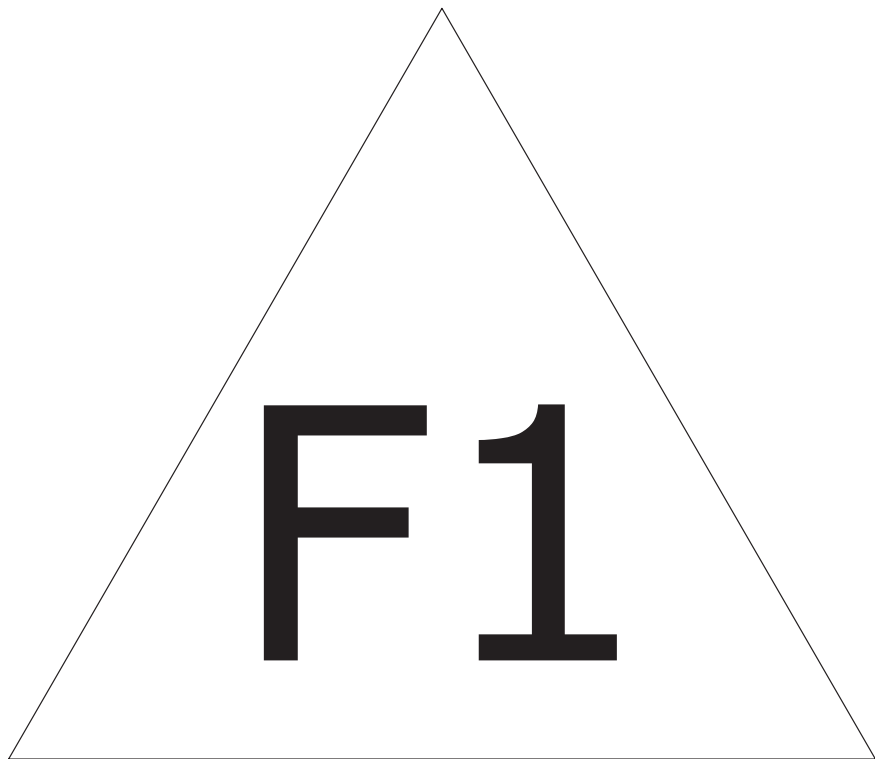

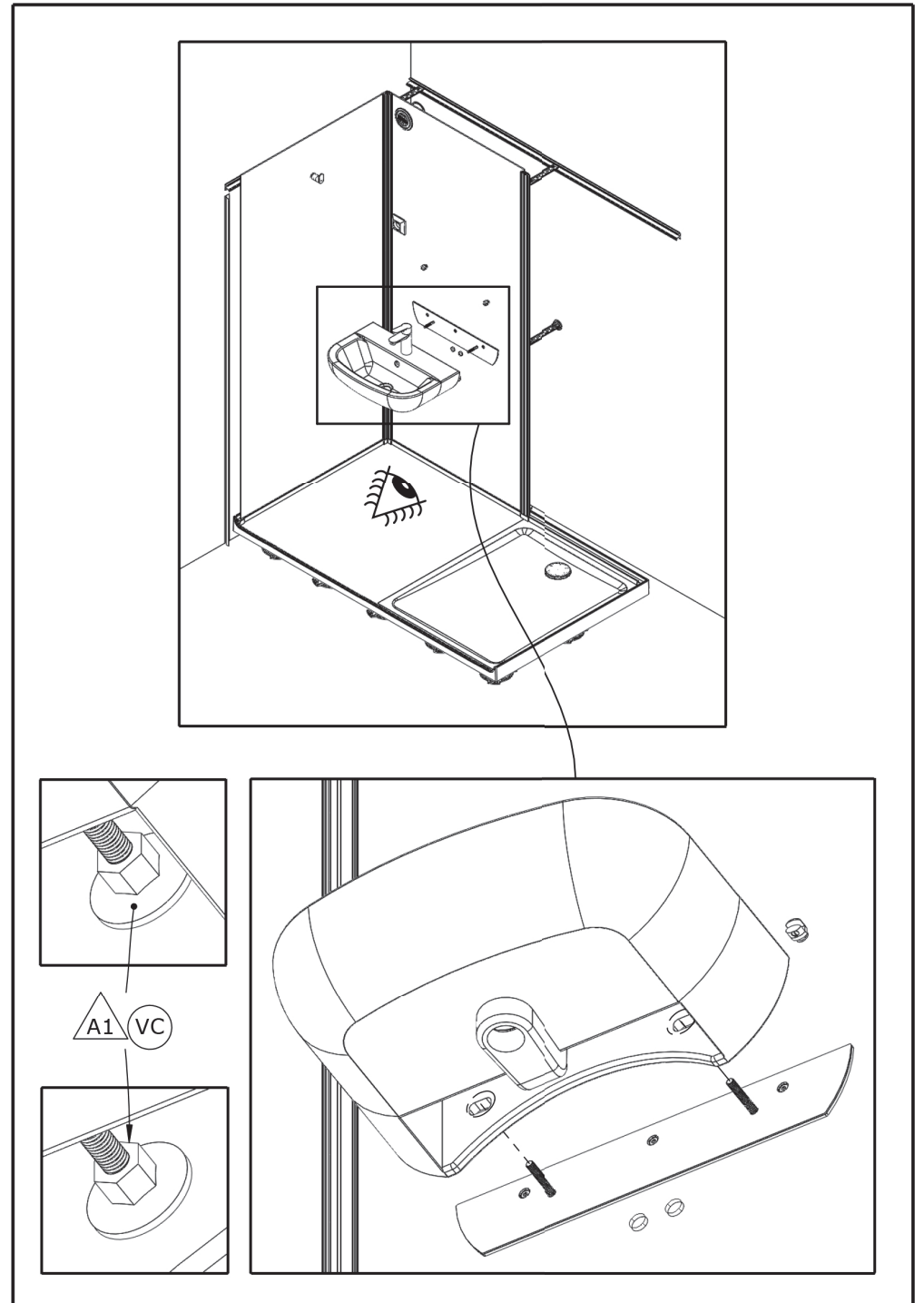
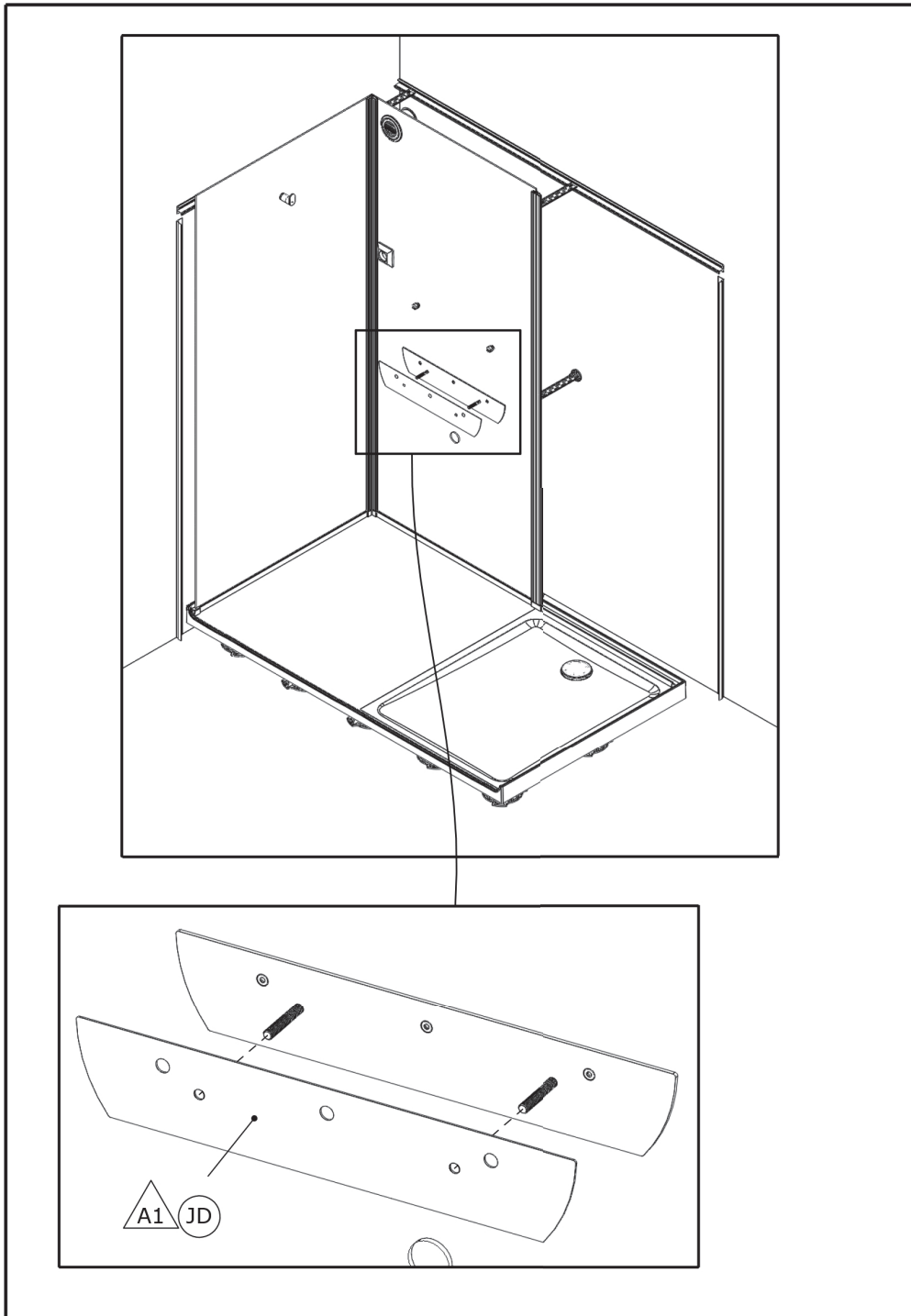

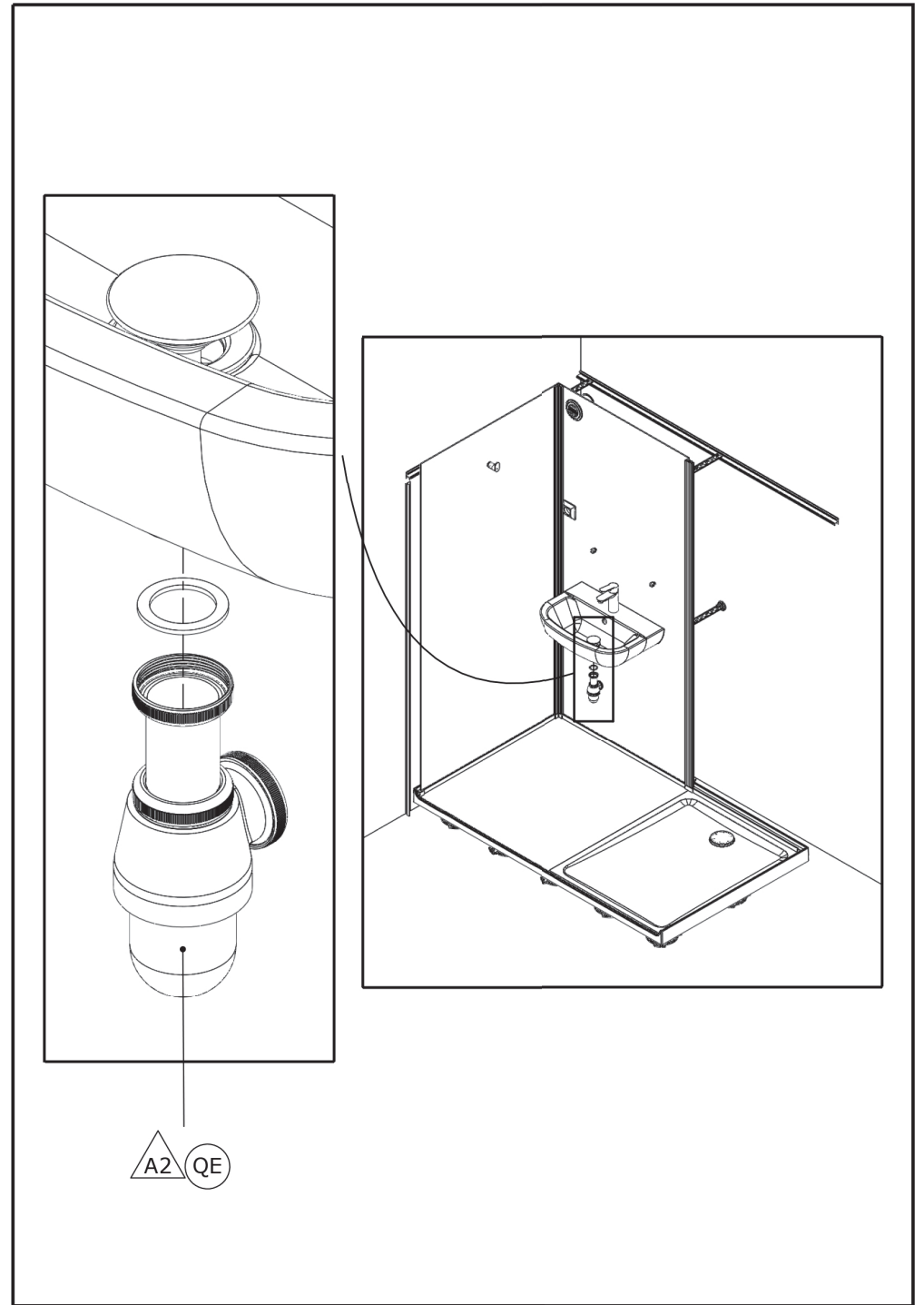
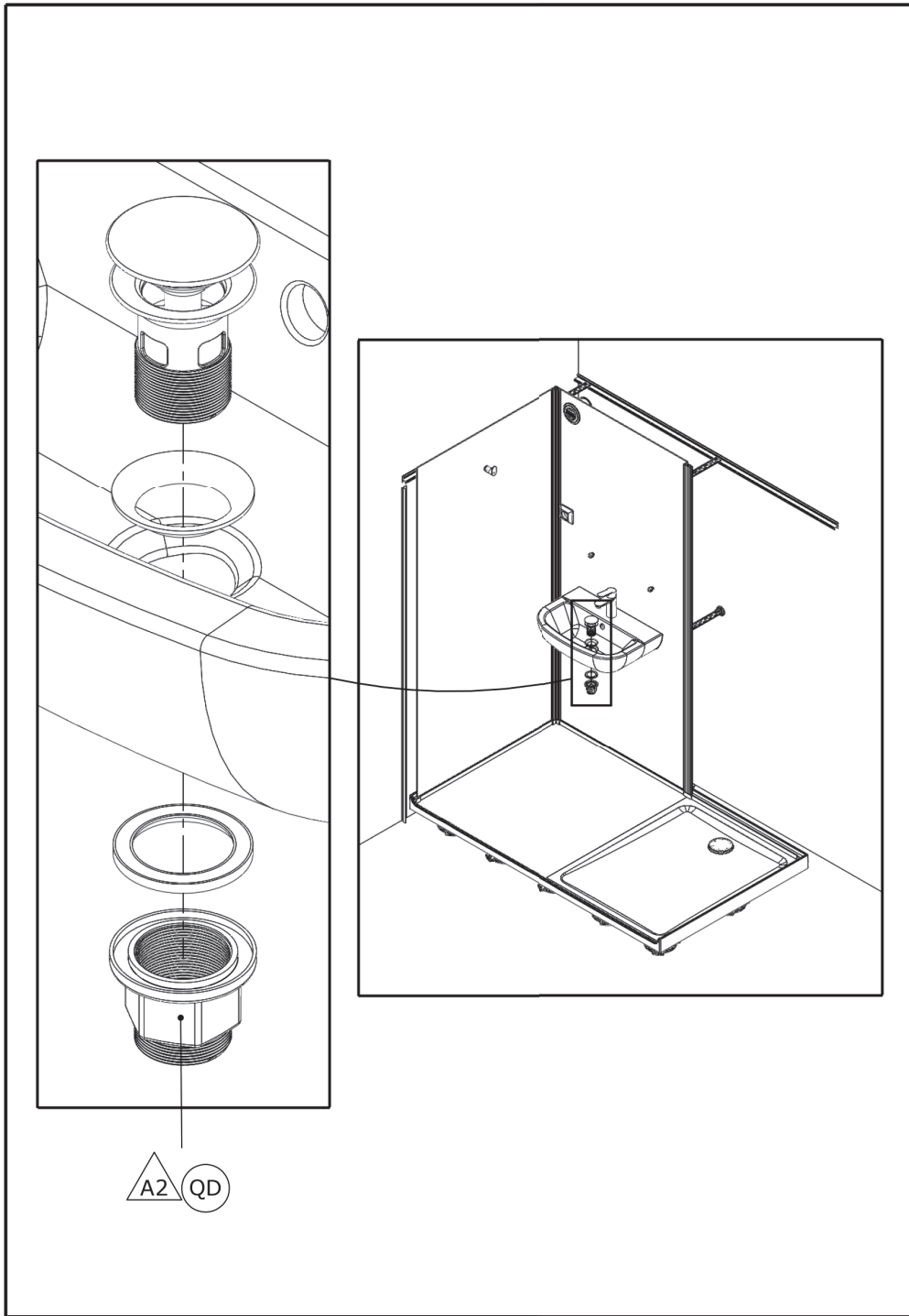

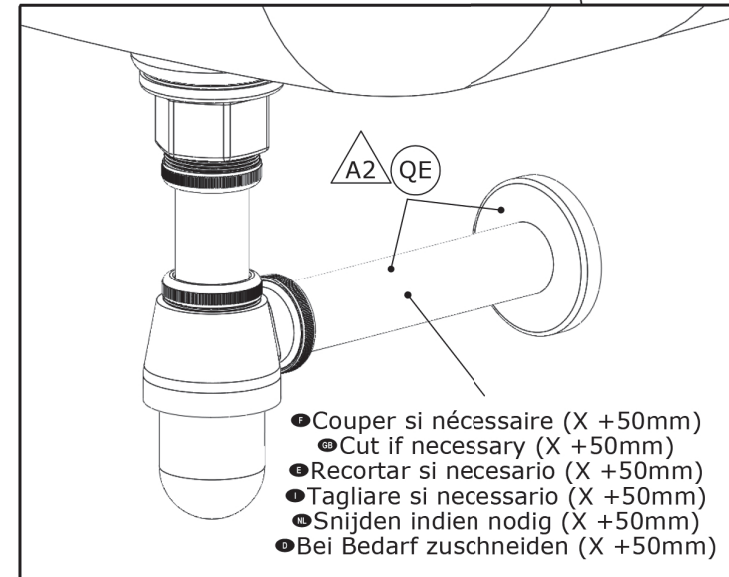
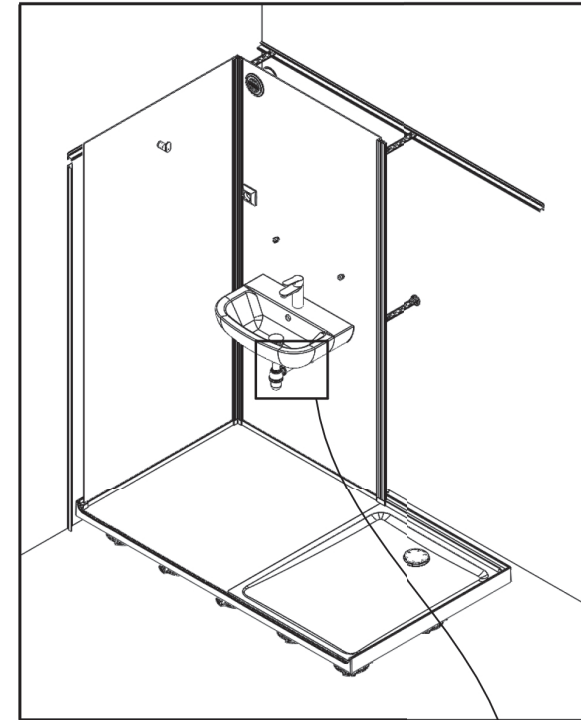
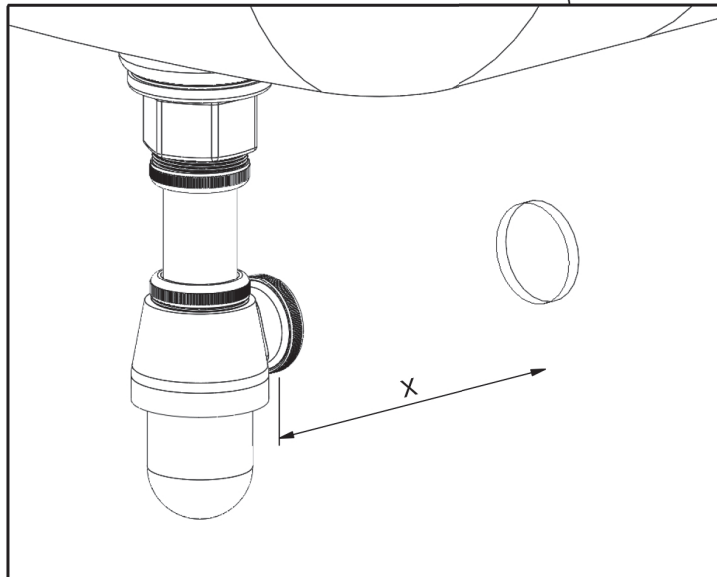
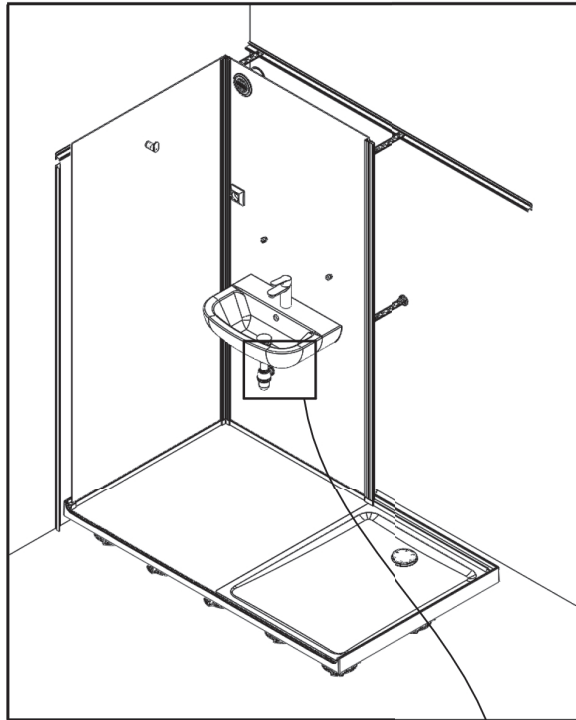

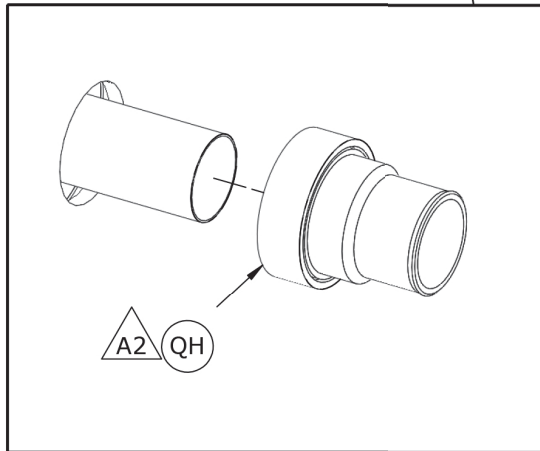
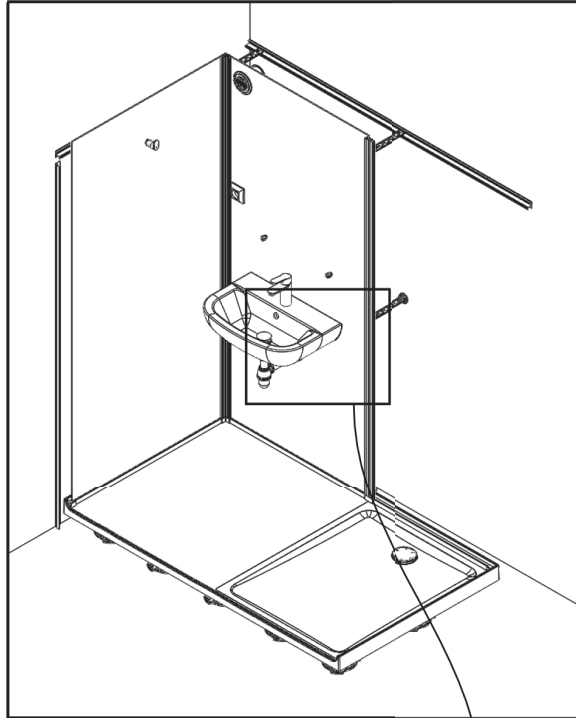

- Vue de derrière • Back view
- Vista trasera • Vista posteriore
- Zicht naar achteren • Rückansicht

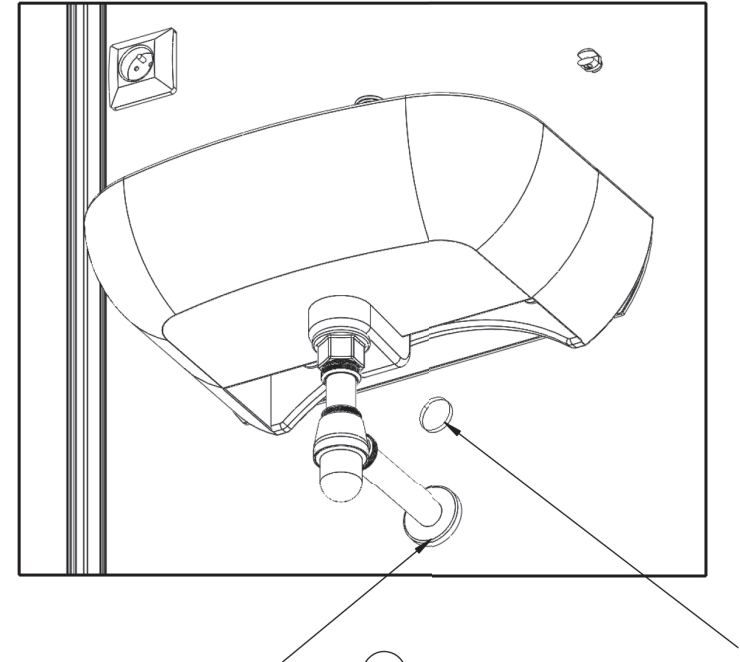

1

- Raccordement évacuation
- Drain connection
- Conexión de drenaje
- Collegamento dello scarico
- Afvoeraansluiting
- Entleerungsanschluss

2

- Raccordement alimentation
- Power supply connection
- Conexión de la fuente de alimentación
- Collegamento all'alimentazione
- Aansluiting op de stroomvoorziening
- Anschluss der Stromversorgung

3

- Effectuer un test en eau avant de poursuivre le montage
- Perform a water test before continuing with the assembly
- Realice una prueba de agua antes de continuar con el montaje
- Eseguire un test dell'acqua prima di continuare con l'assemblaggio
- Voer een watertest uit voordat u verder gaat met de montage
- Führen Sie einen Wassertest durch, bevor Sie mit der Montage fortfahren

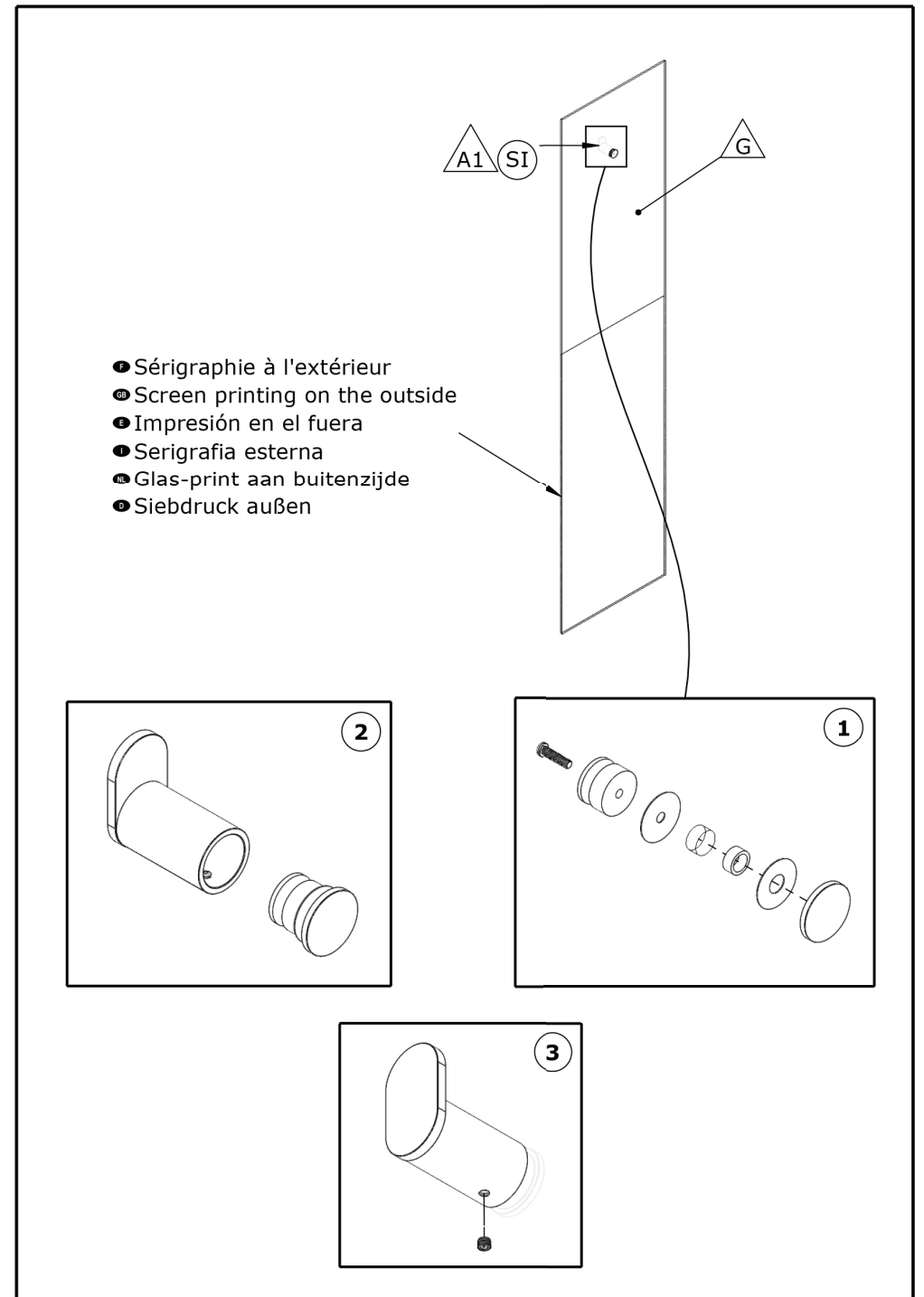
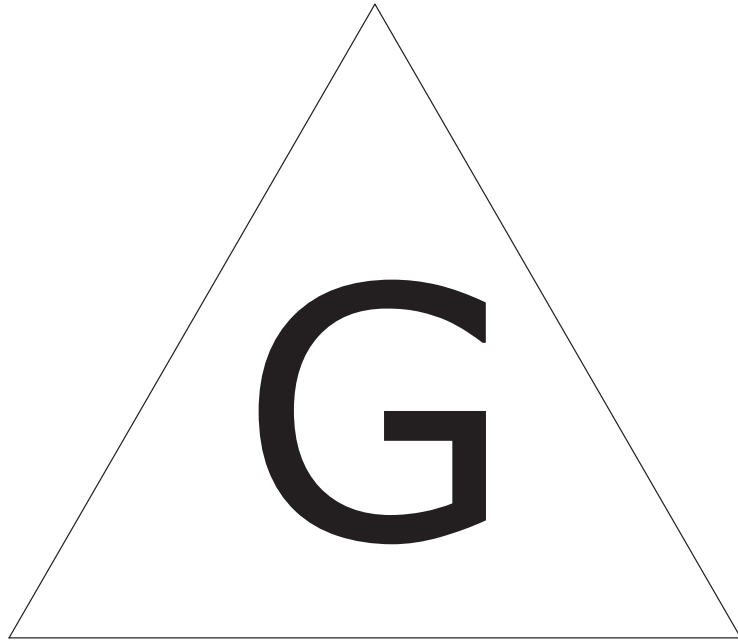

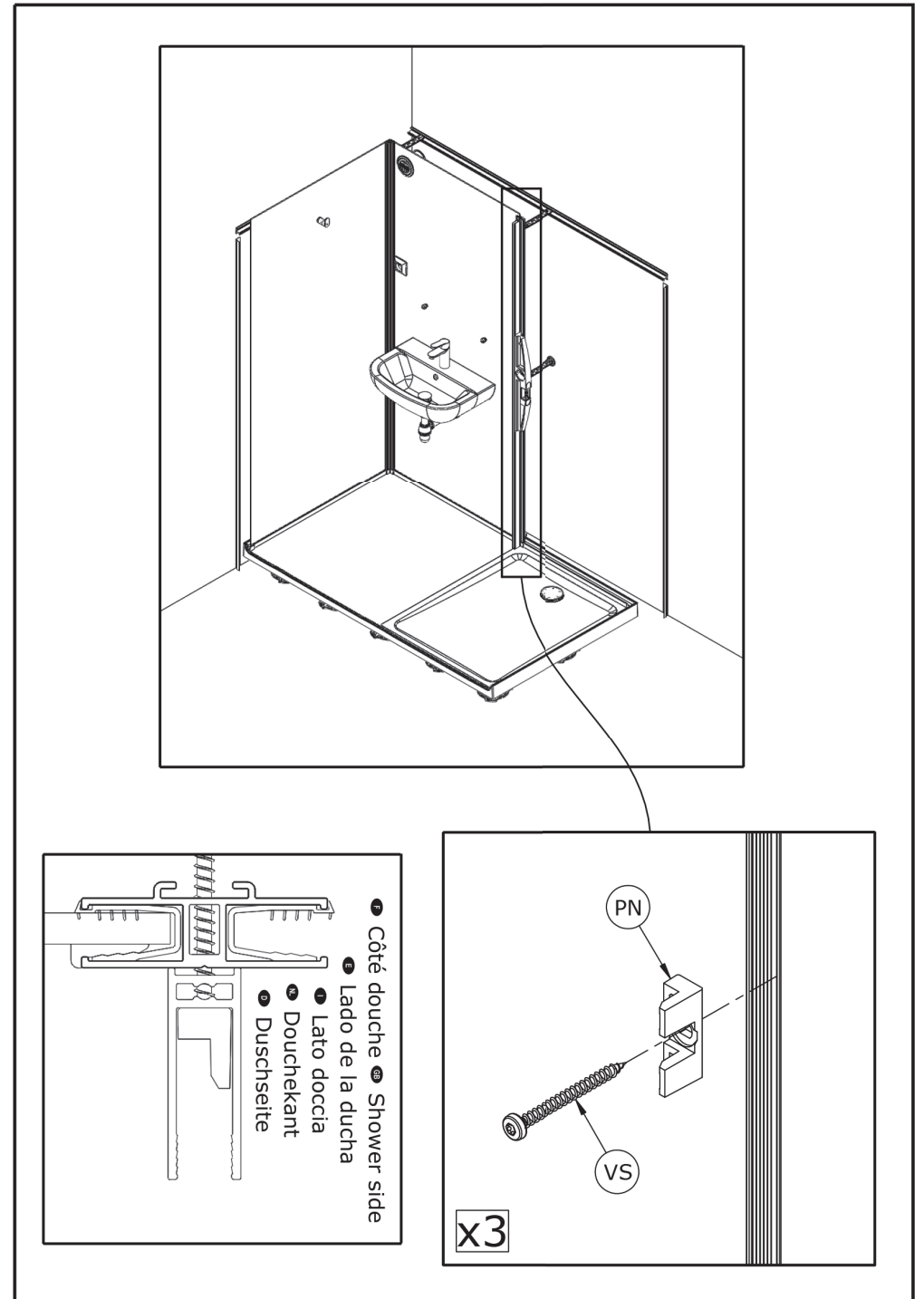
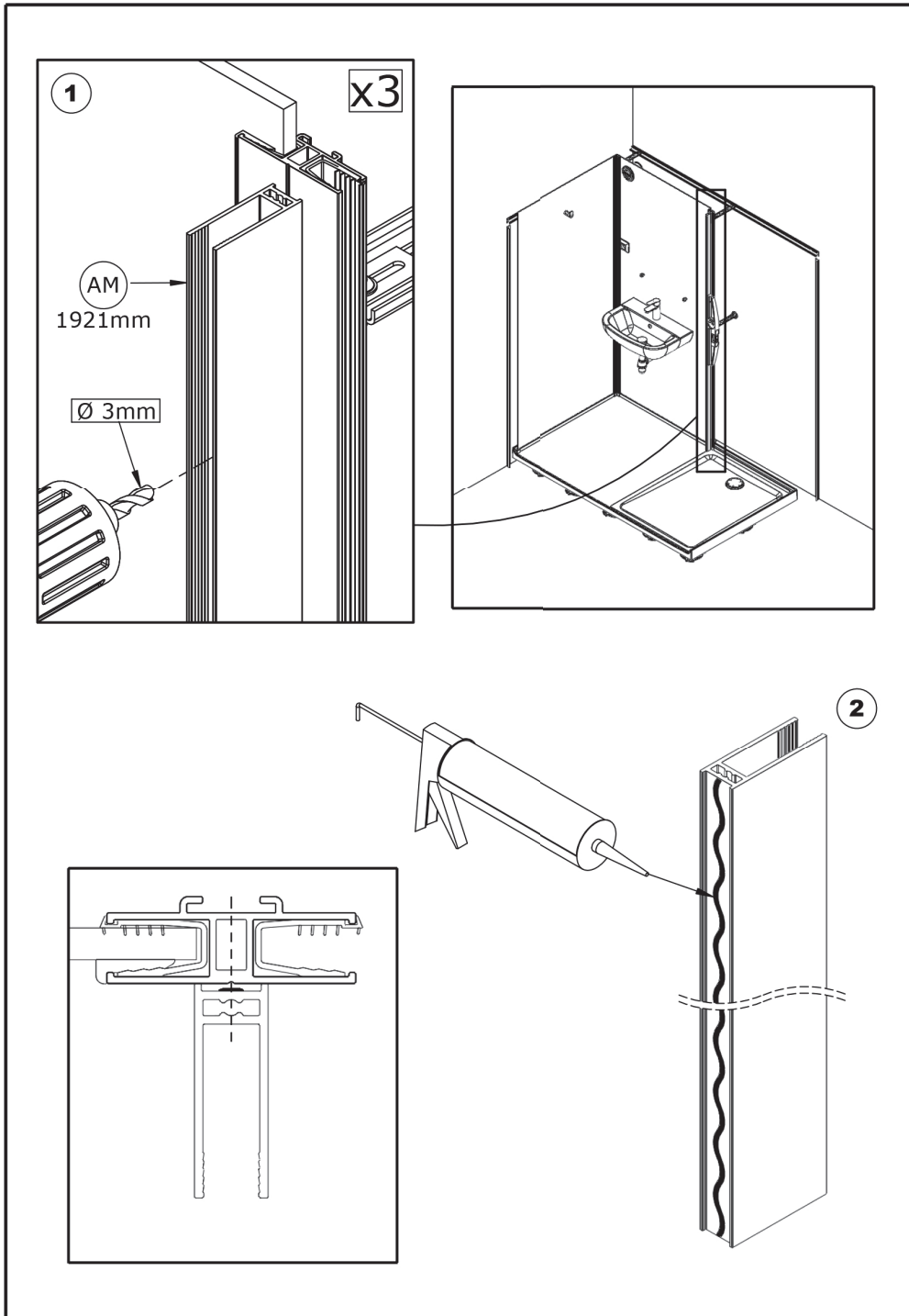

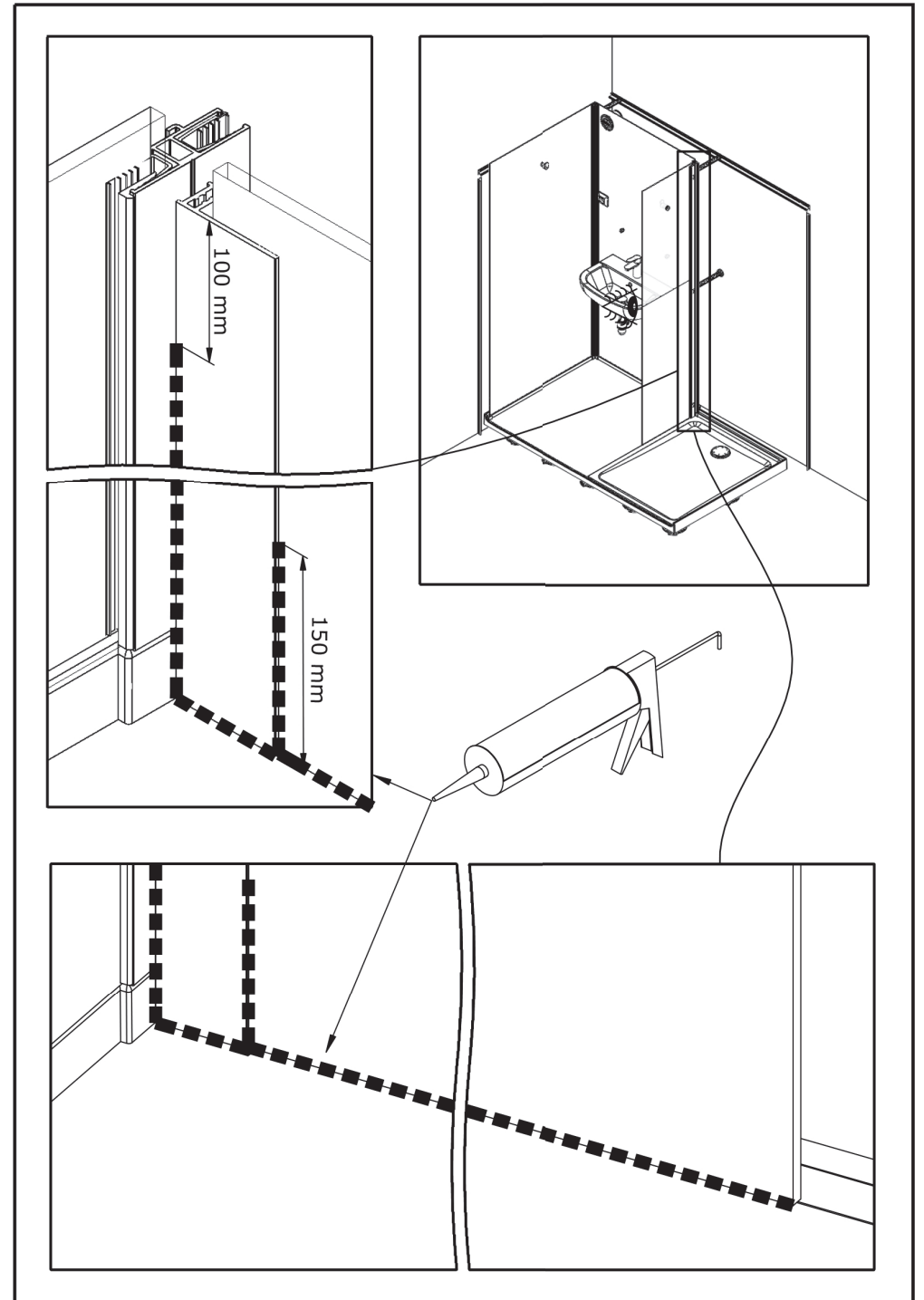
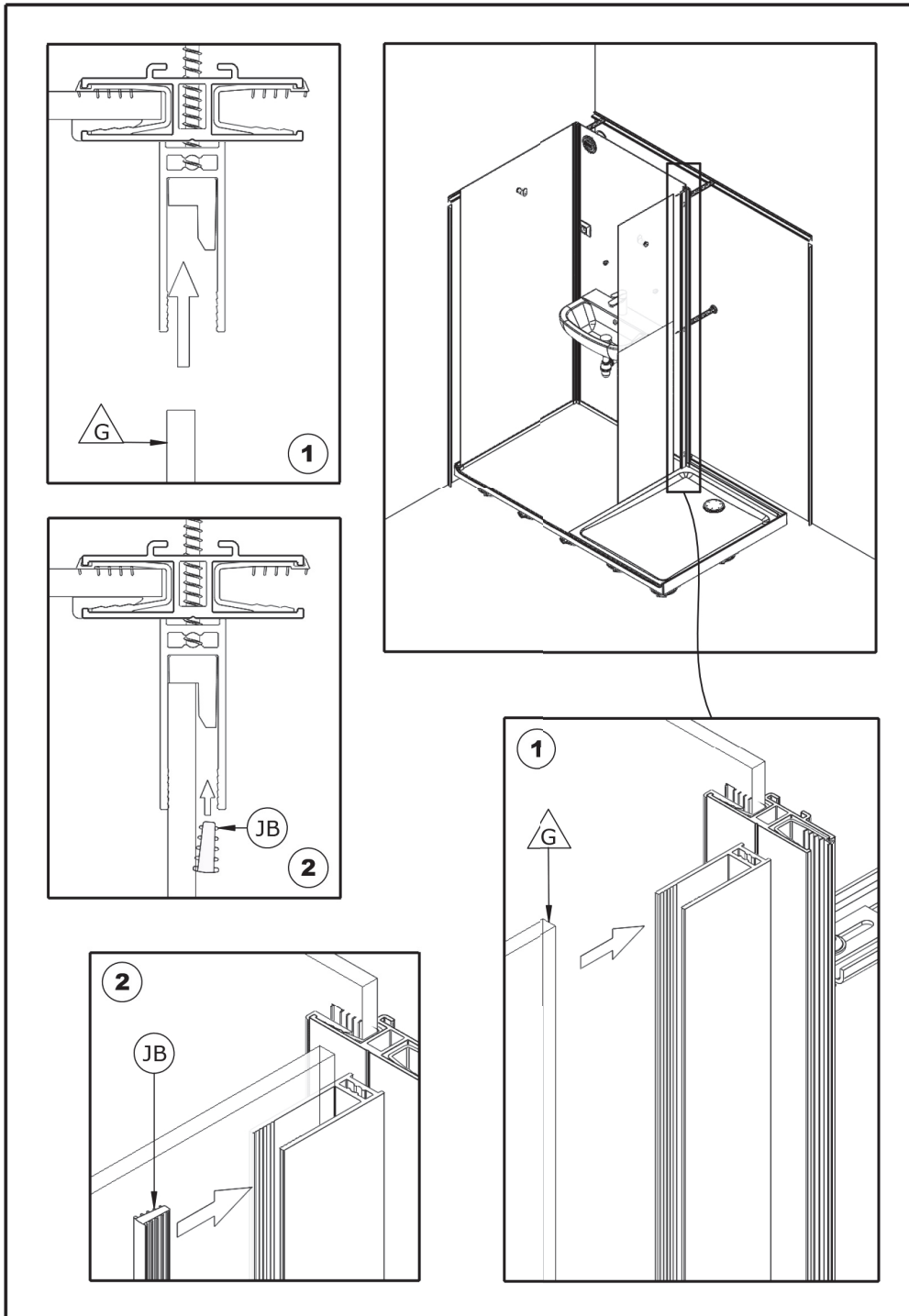

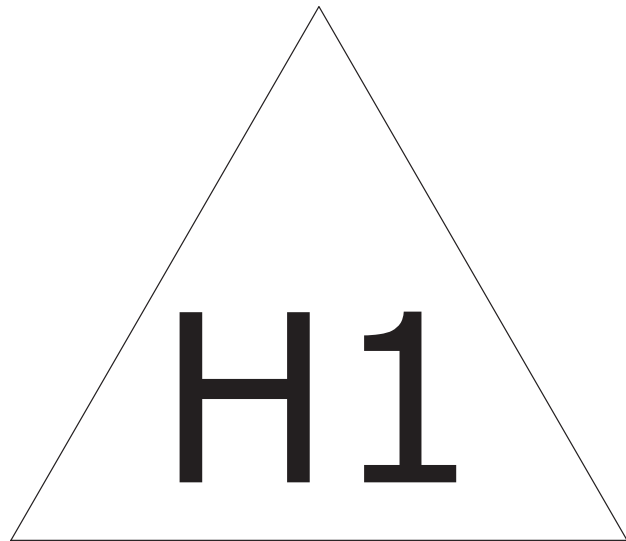

+

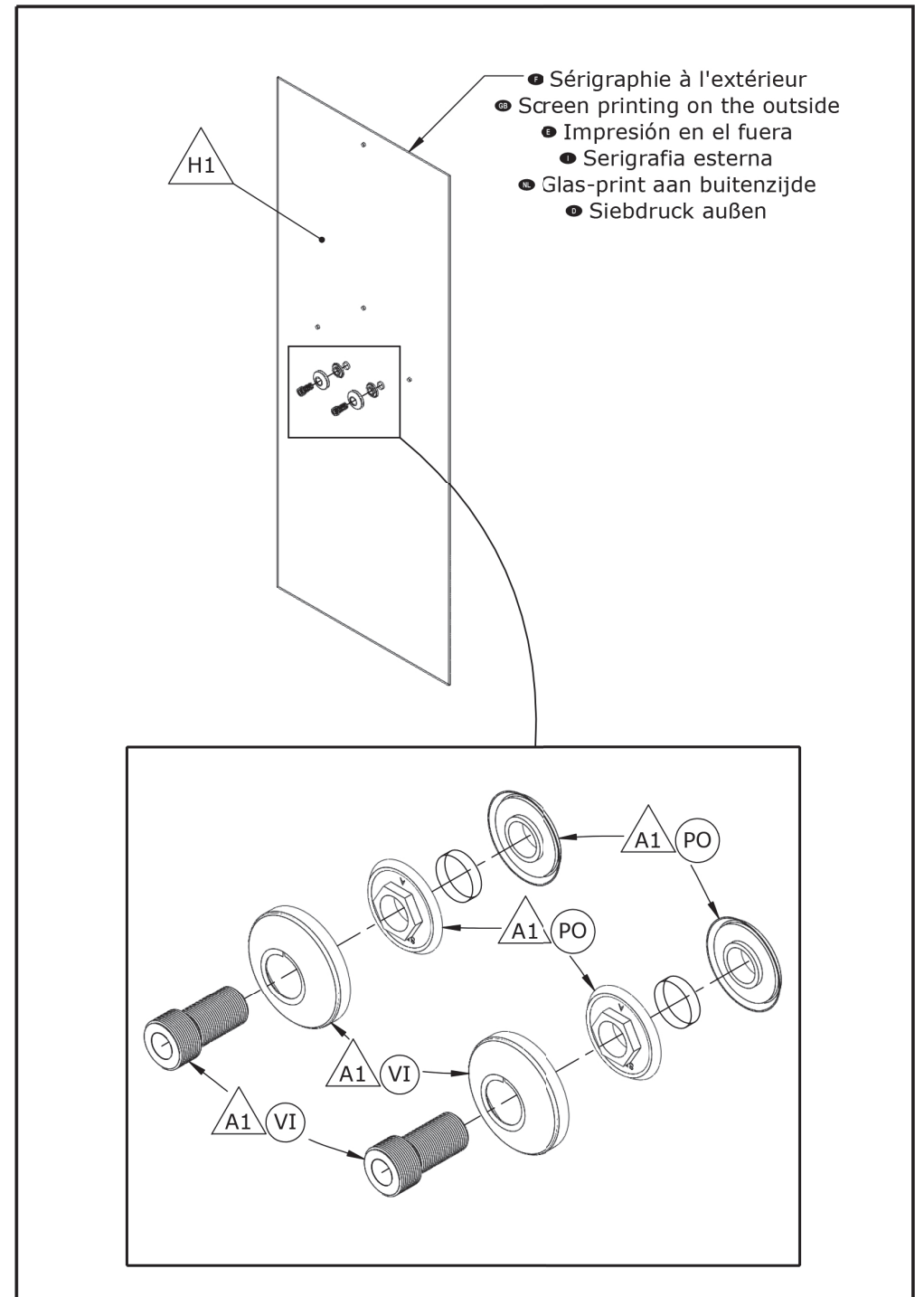

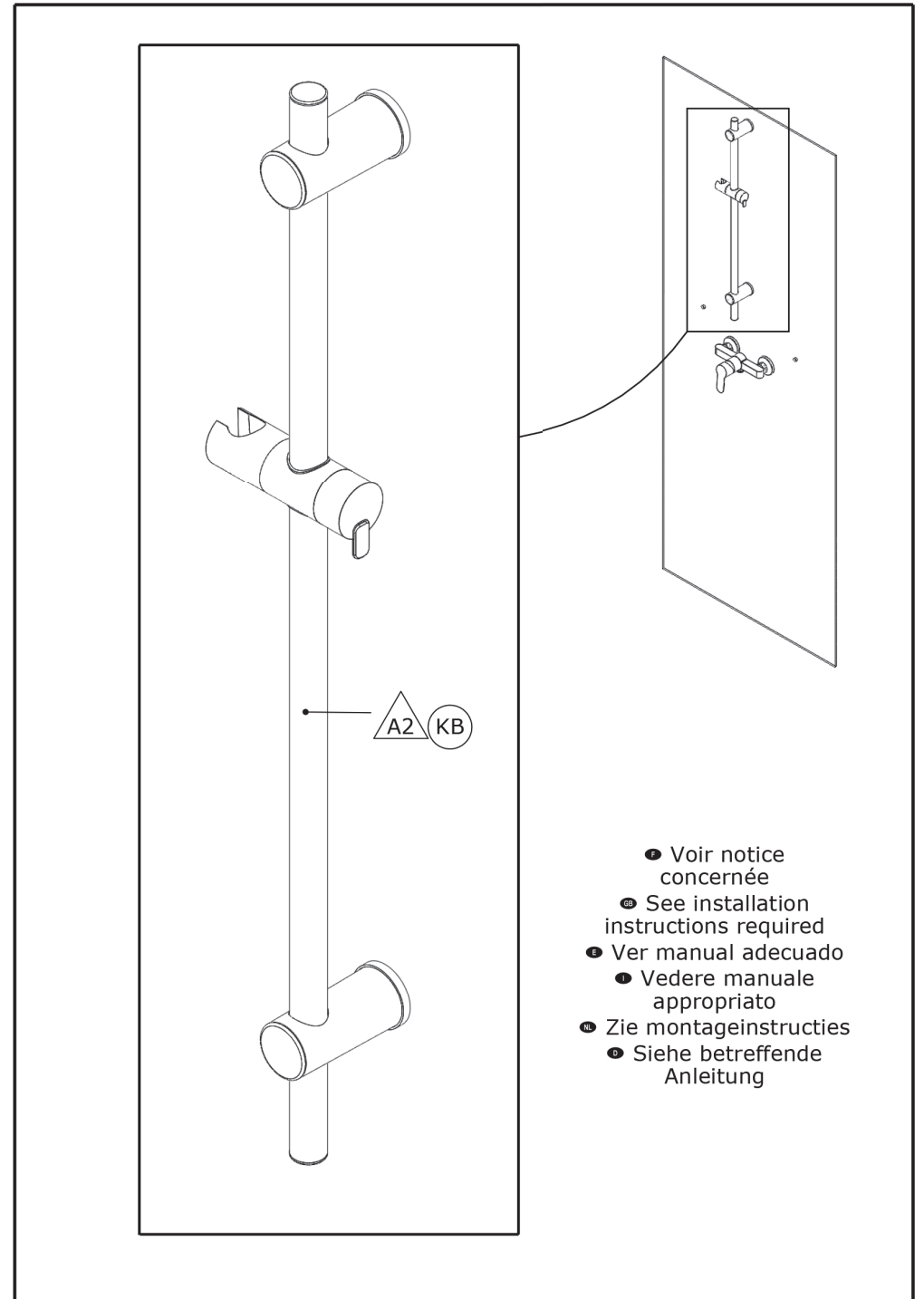
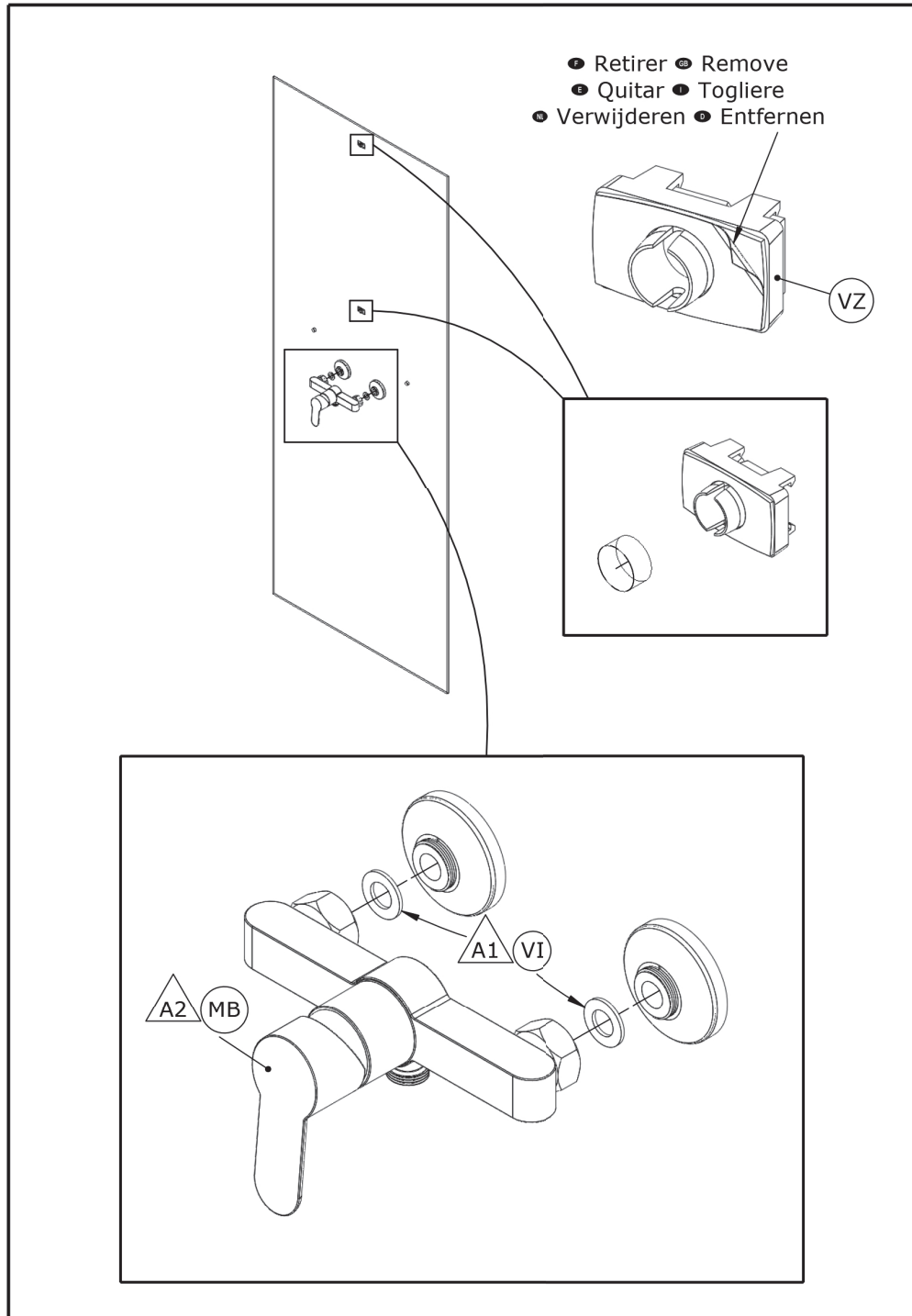

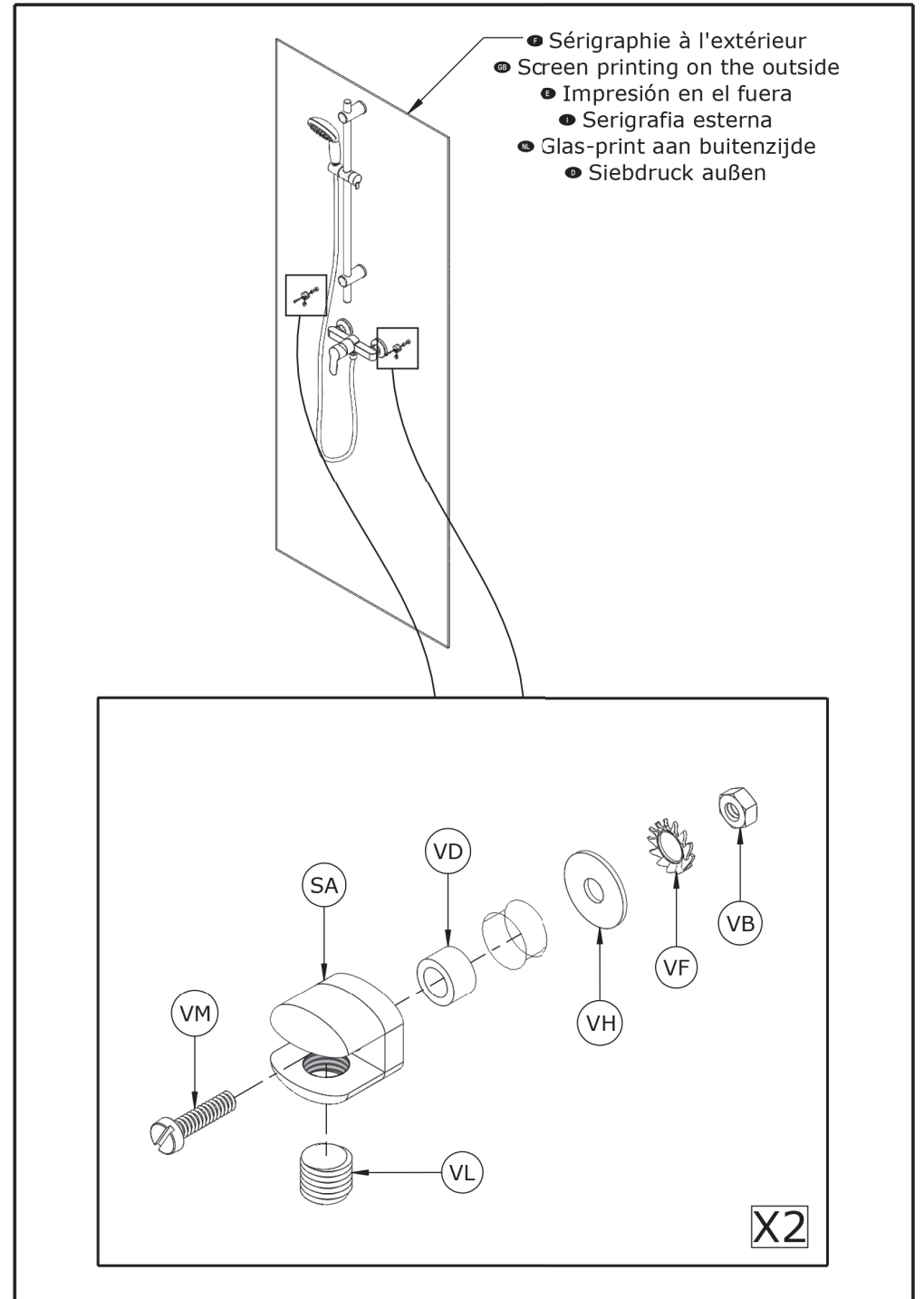
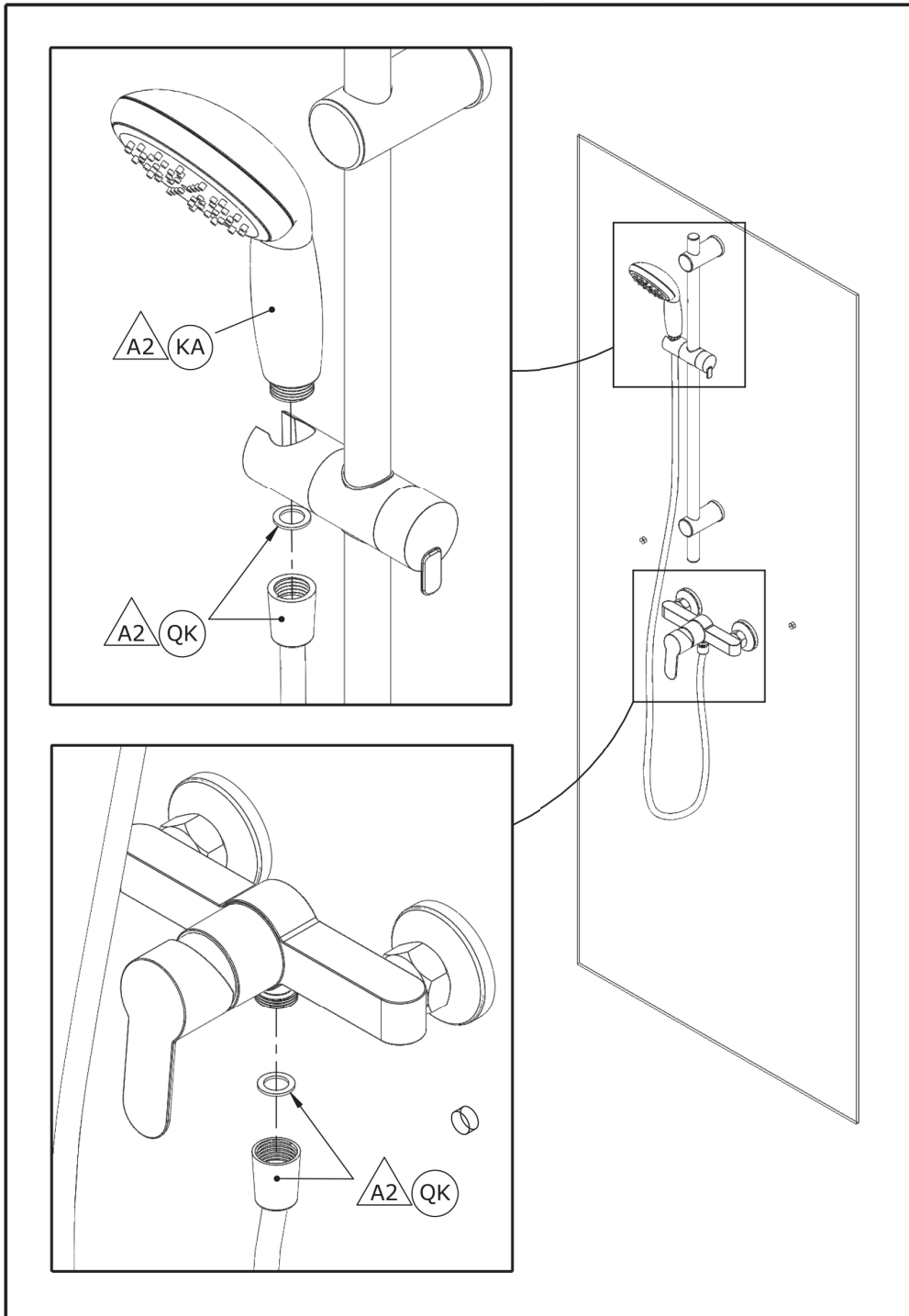

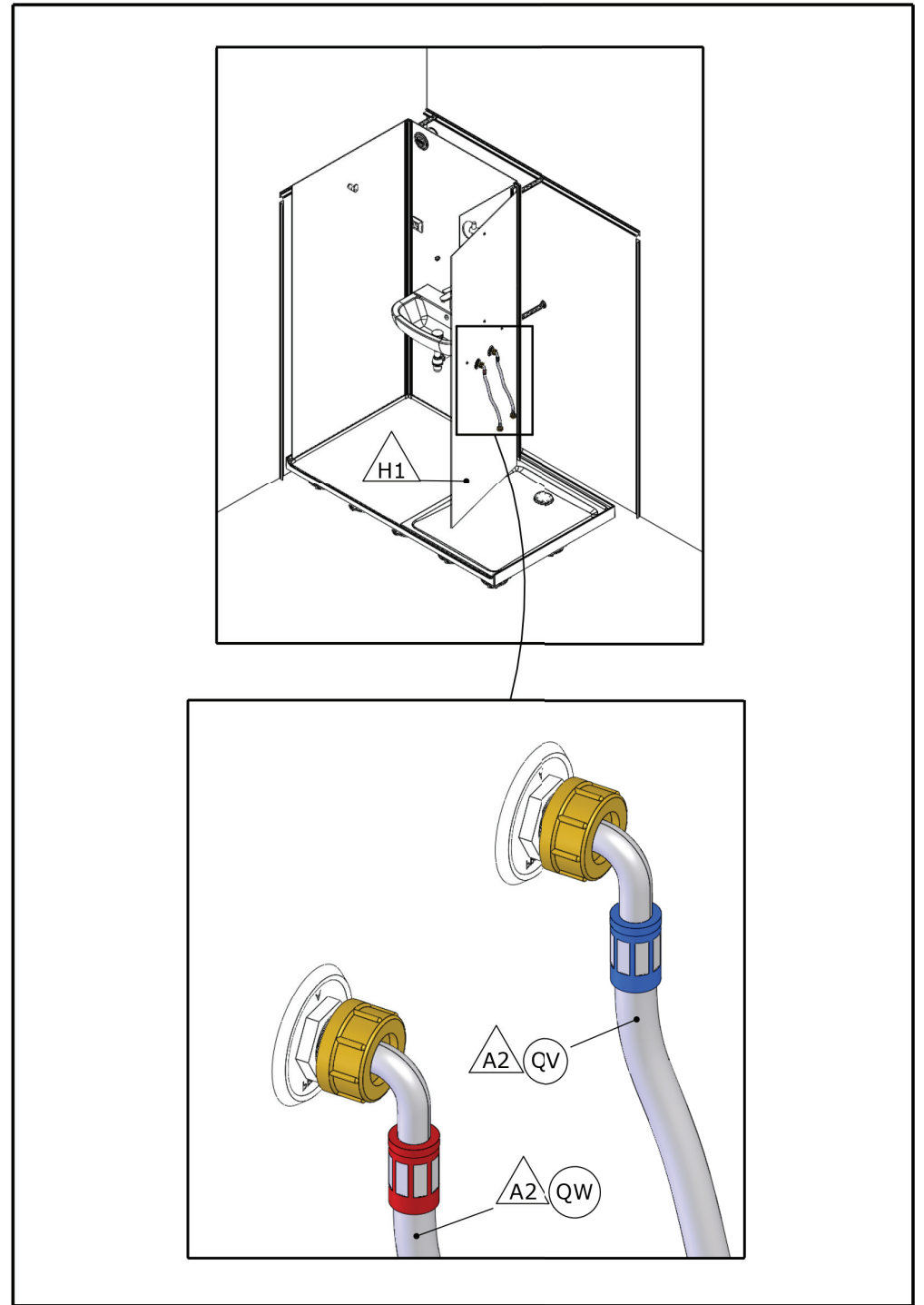
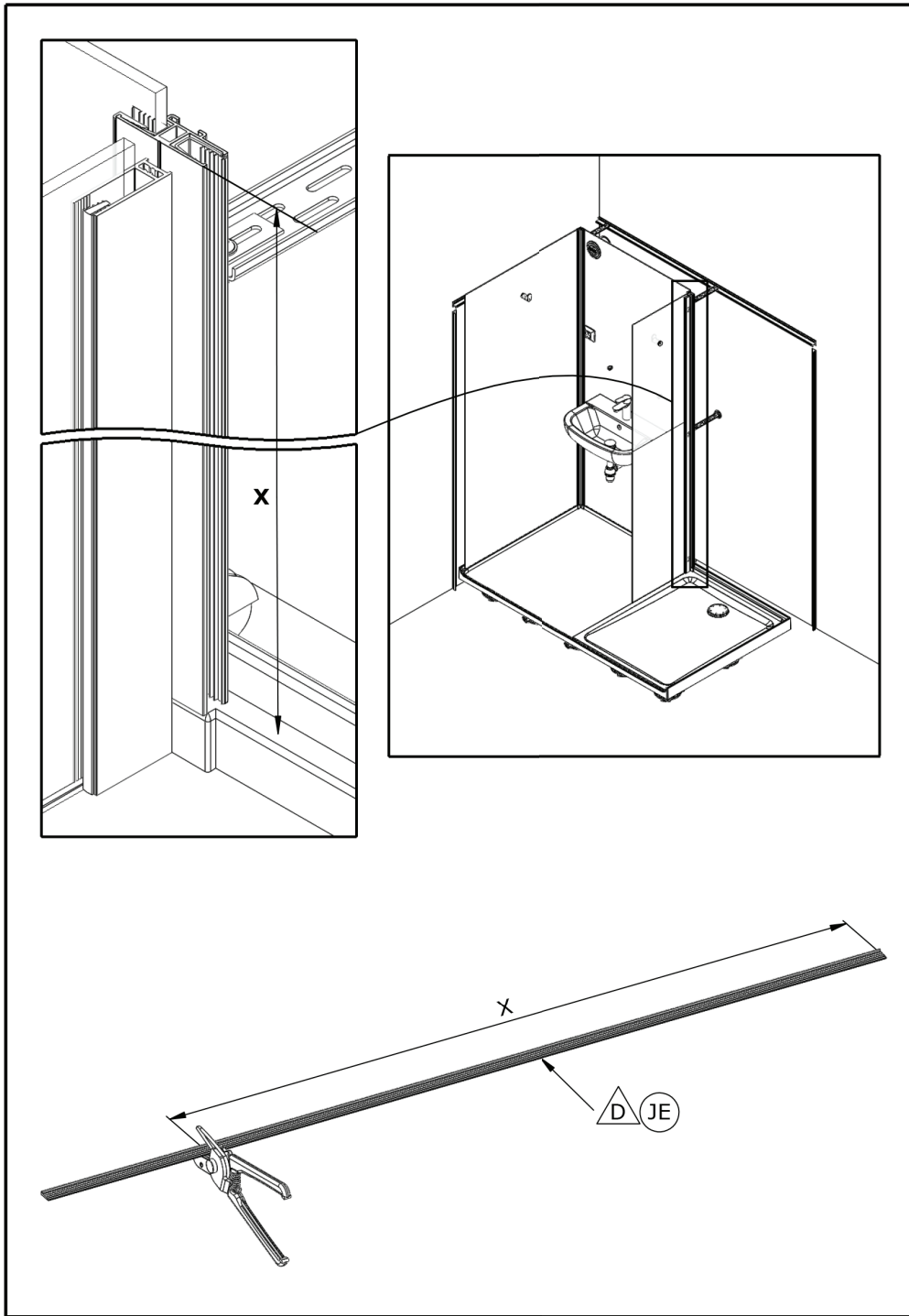

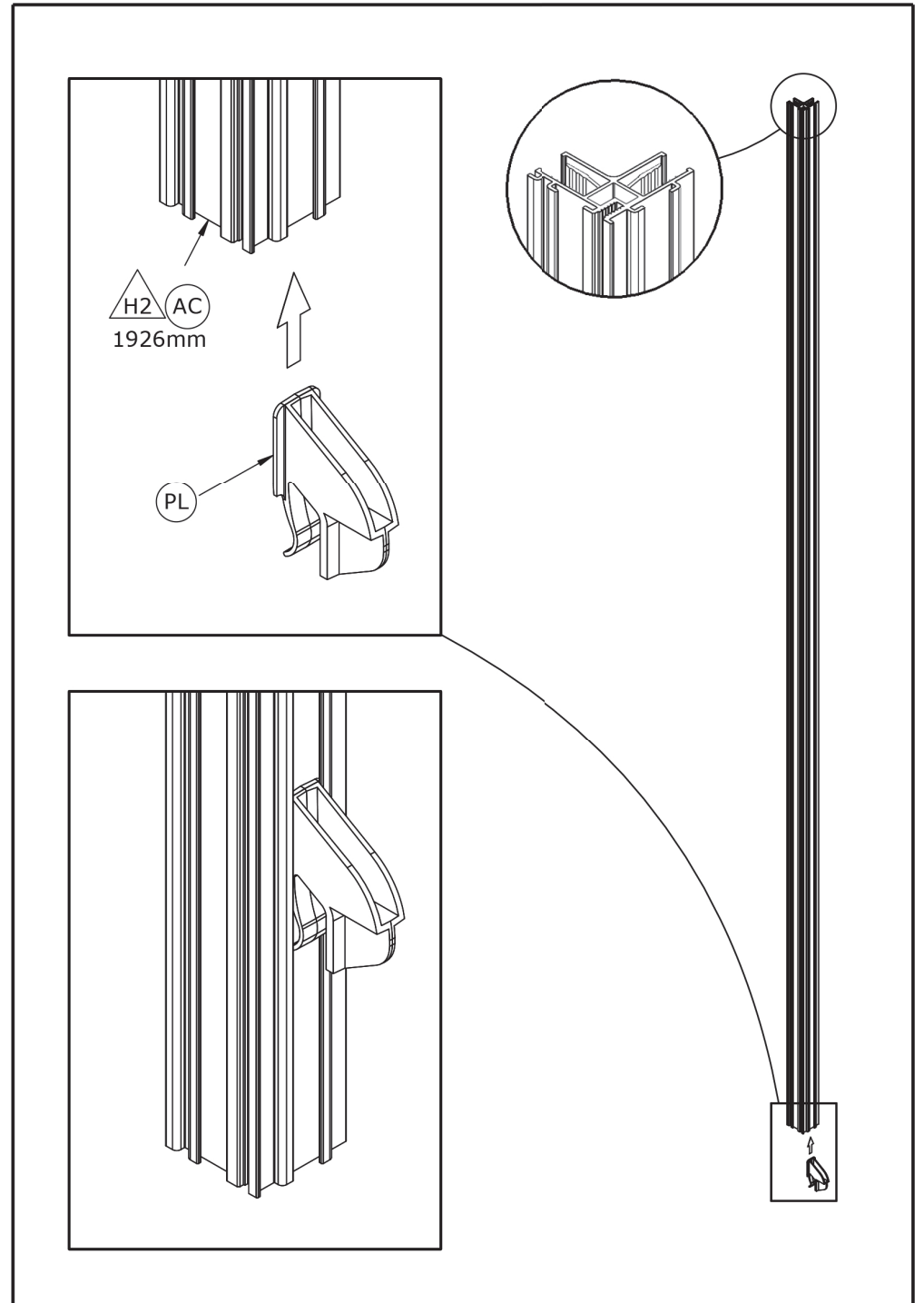
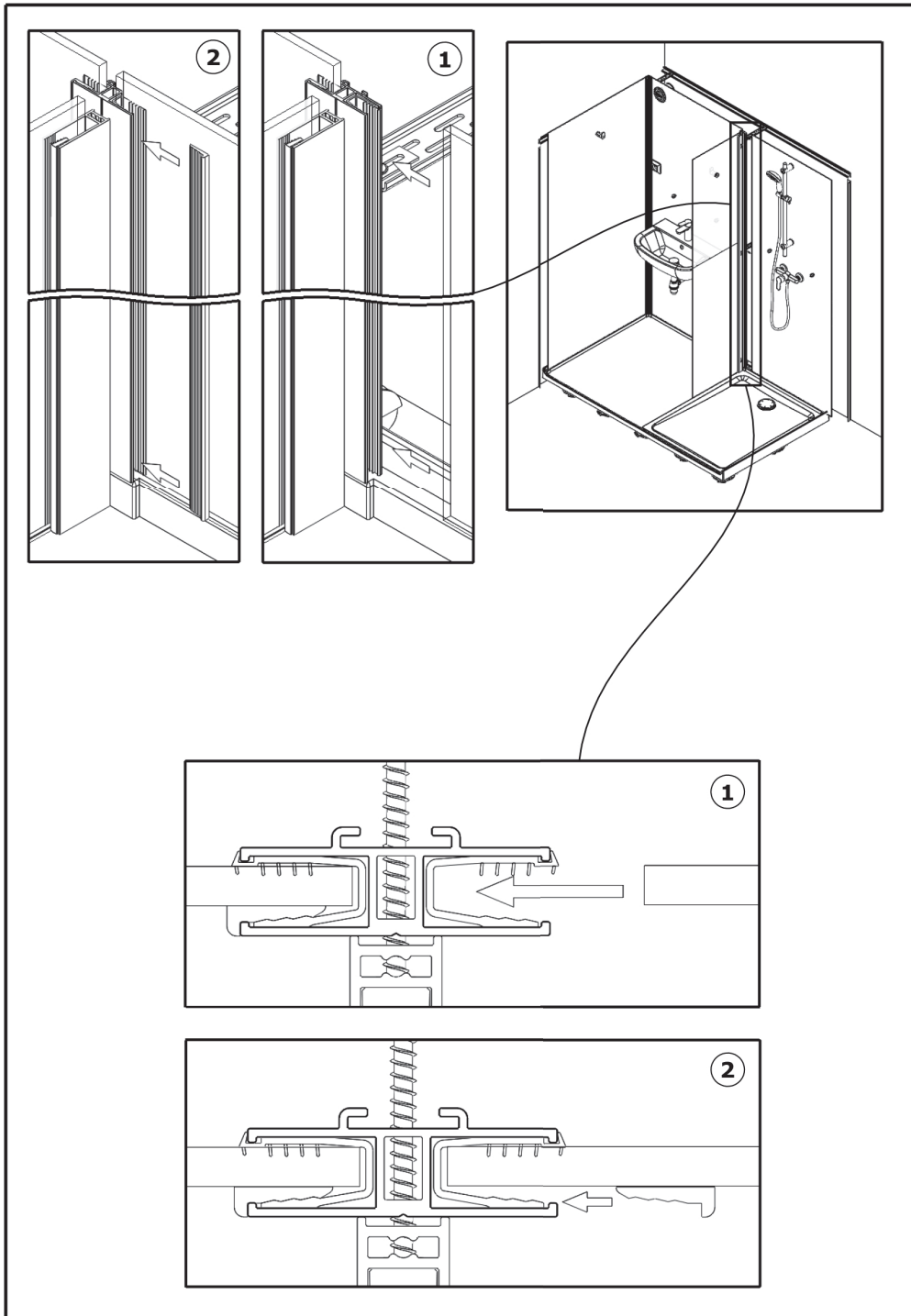

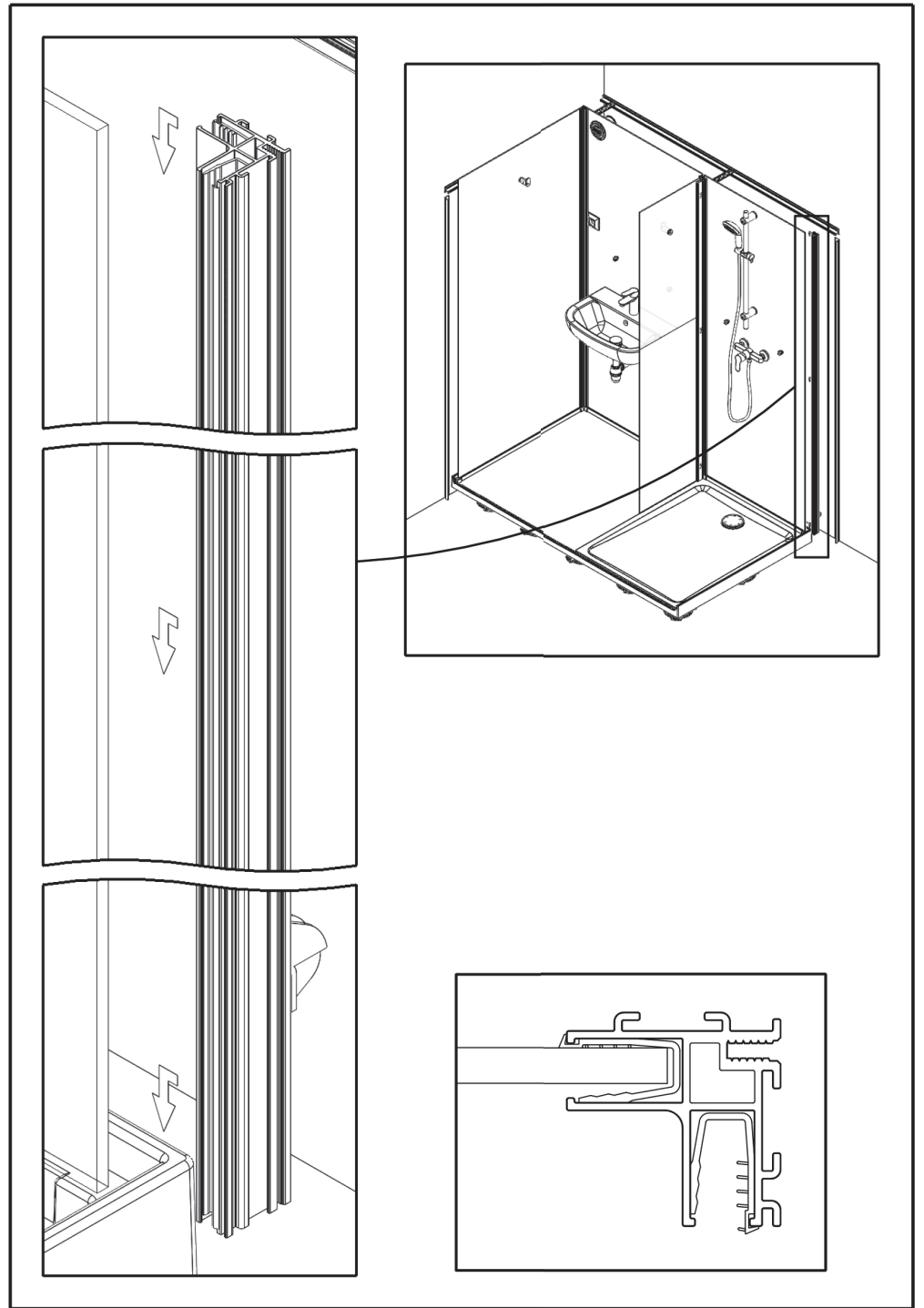
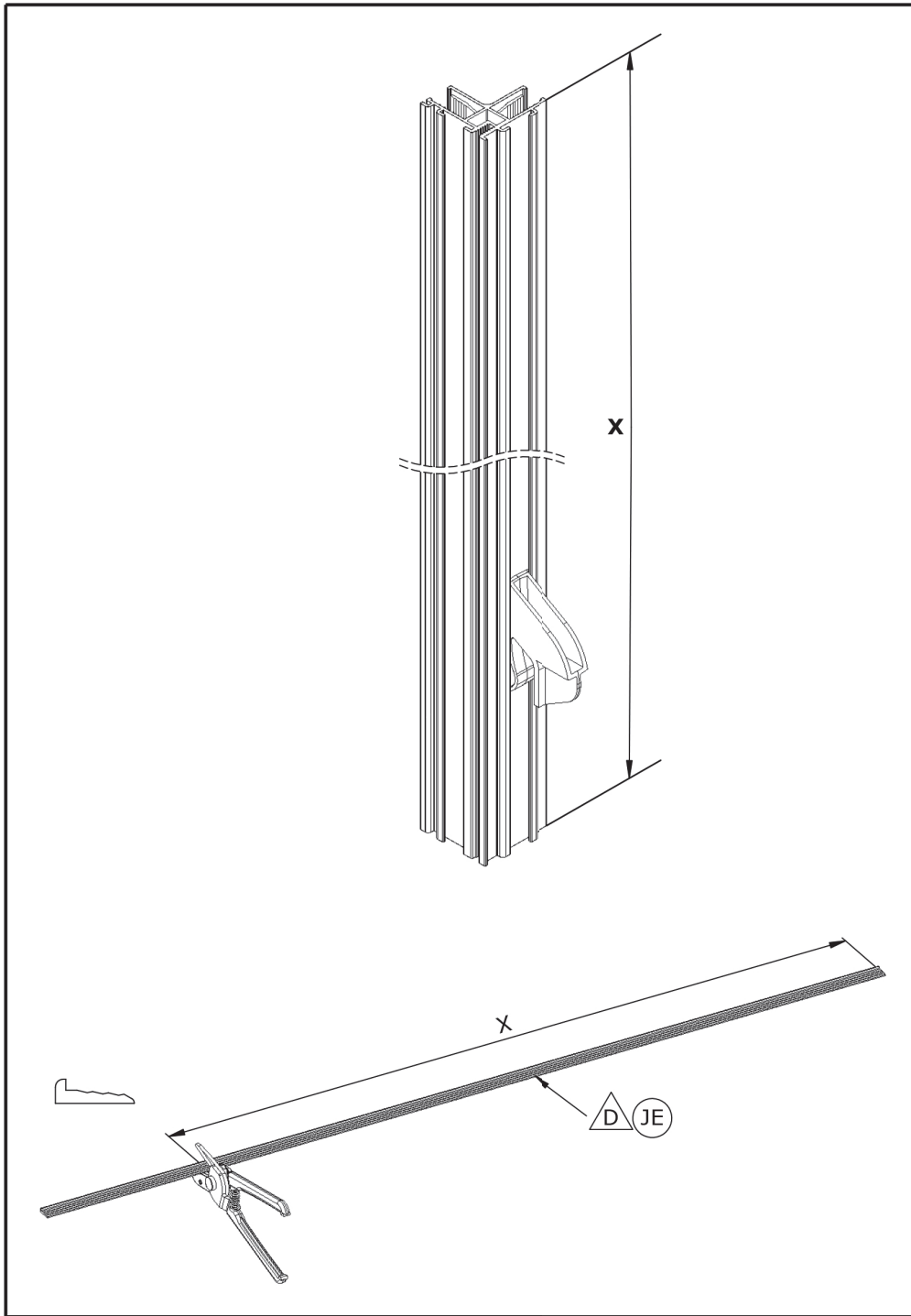

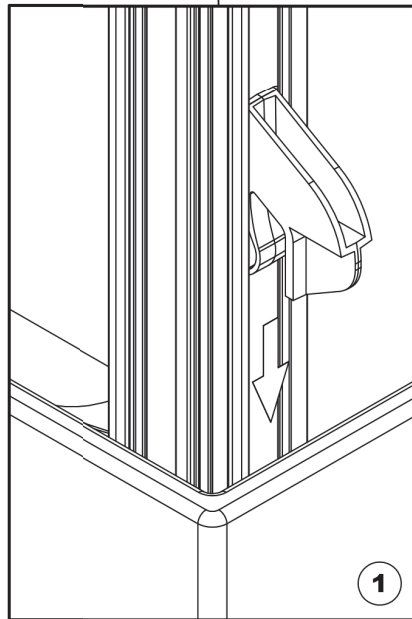
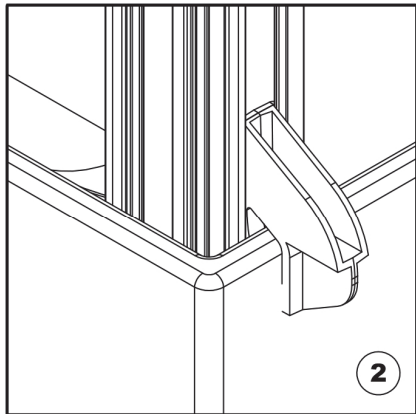
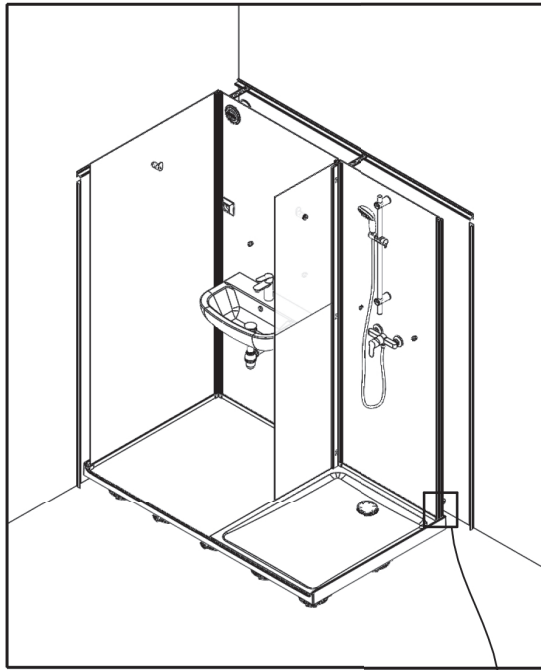

• Vue de derrière • Back view
 • Vista trasera • Vista posteriore
 • Zicht naar achteren • Rückansicht

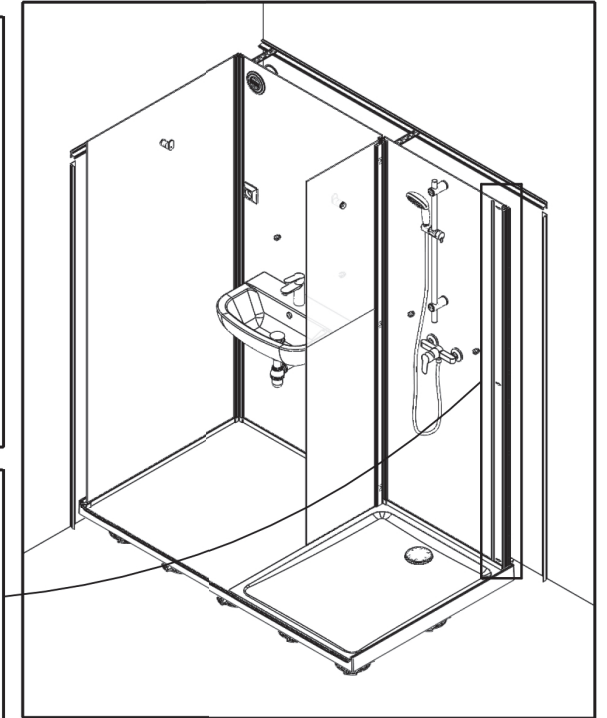
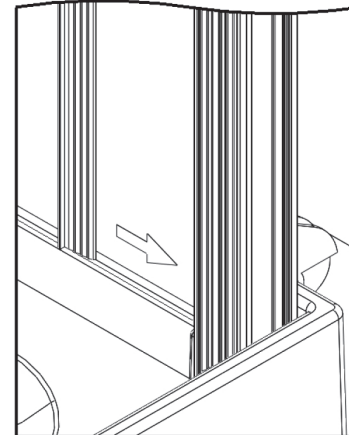
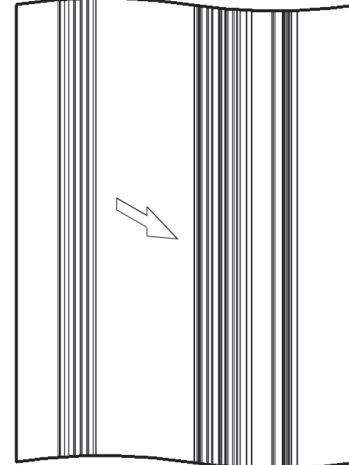
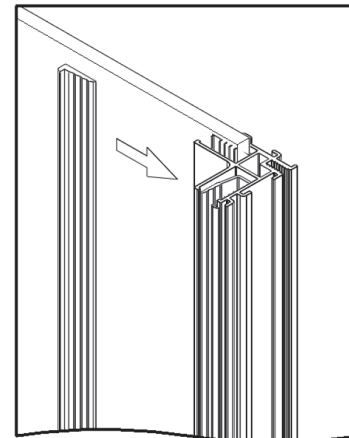

• Ne pas verrouiller • Do not block
 • No bloquear • Non bloccare
 • Blokkeer niet • Nicht blockieren

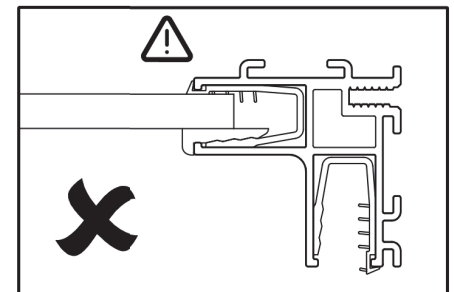
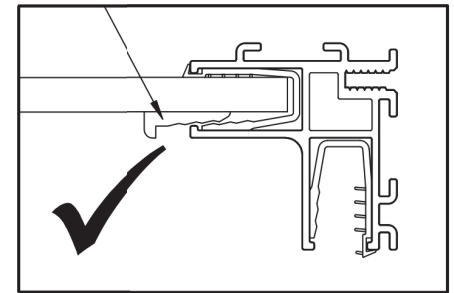

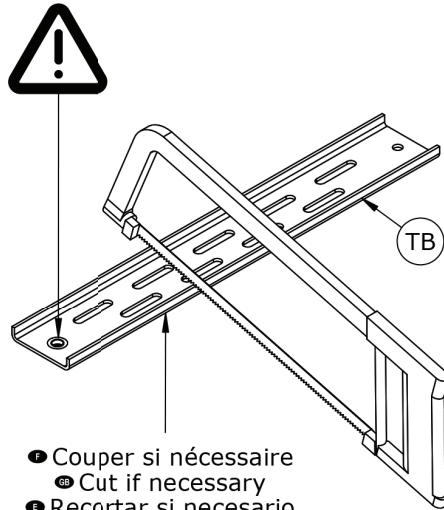
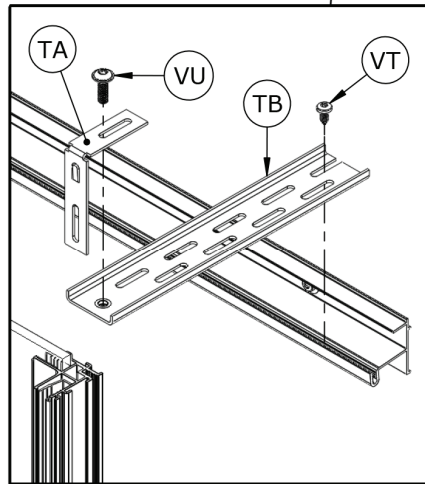
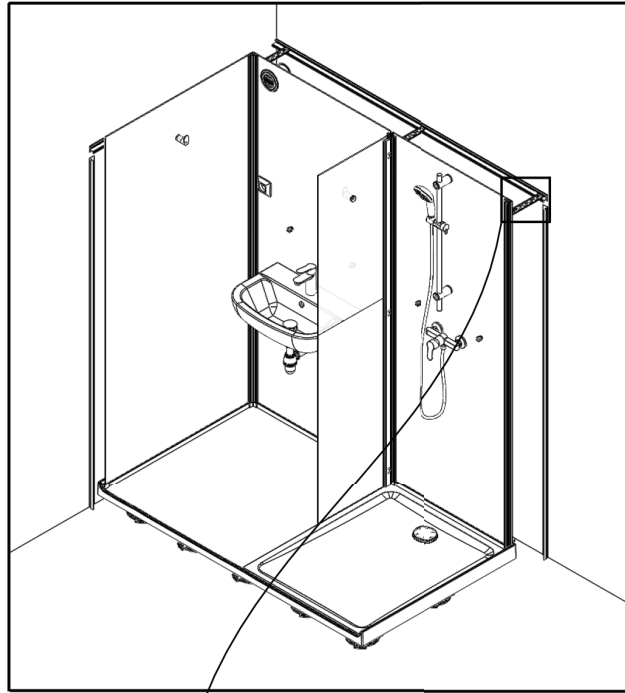

- Couper si nécessaire
- Cut if necessary
- Recortar si necesario
- Tagliare si necessario
- Snijden indien nodig
- Bei Bedarf zuschneiden

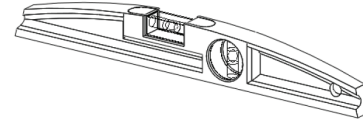

- Vérifier l'aplomb de la cabine, puis verrouiller
- Ensure level then block
- Verificar la verticalidad de la cabina, y bloquear
- Assicurarsi che la doccia è di livello, e bloccare
- Controleer of de douchecabine goed recht staat, en blokkeer
- Prüfen, ob die Kabine lotrecht steht, anschließend blockieren

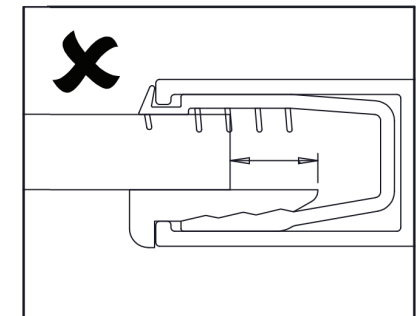
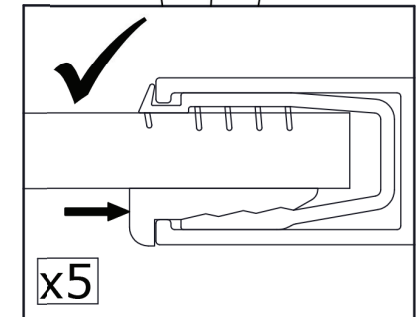
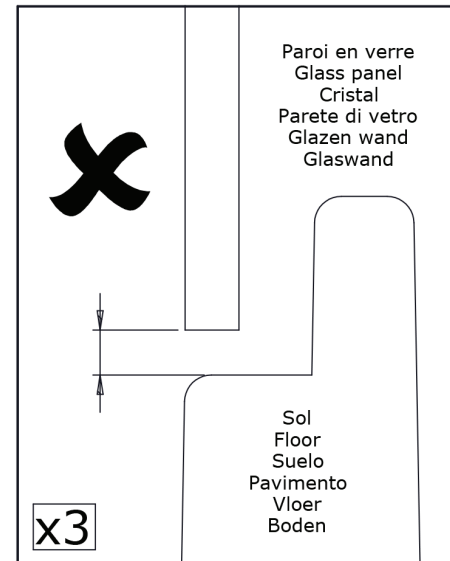
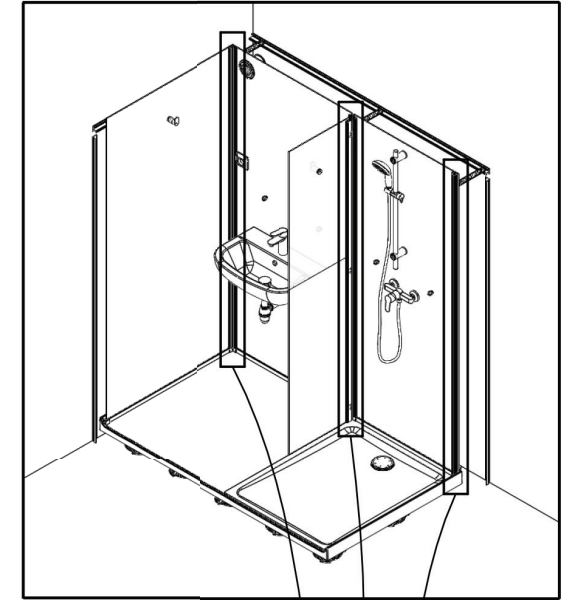

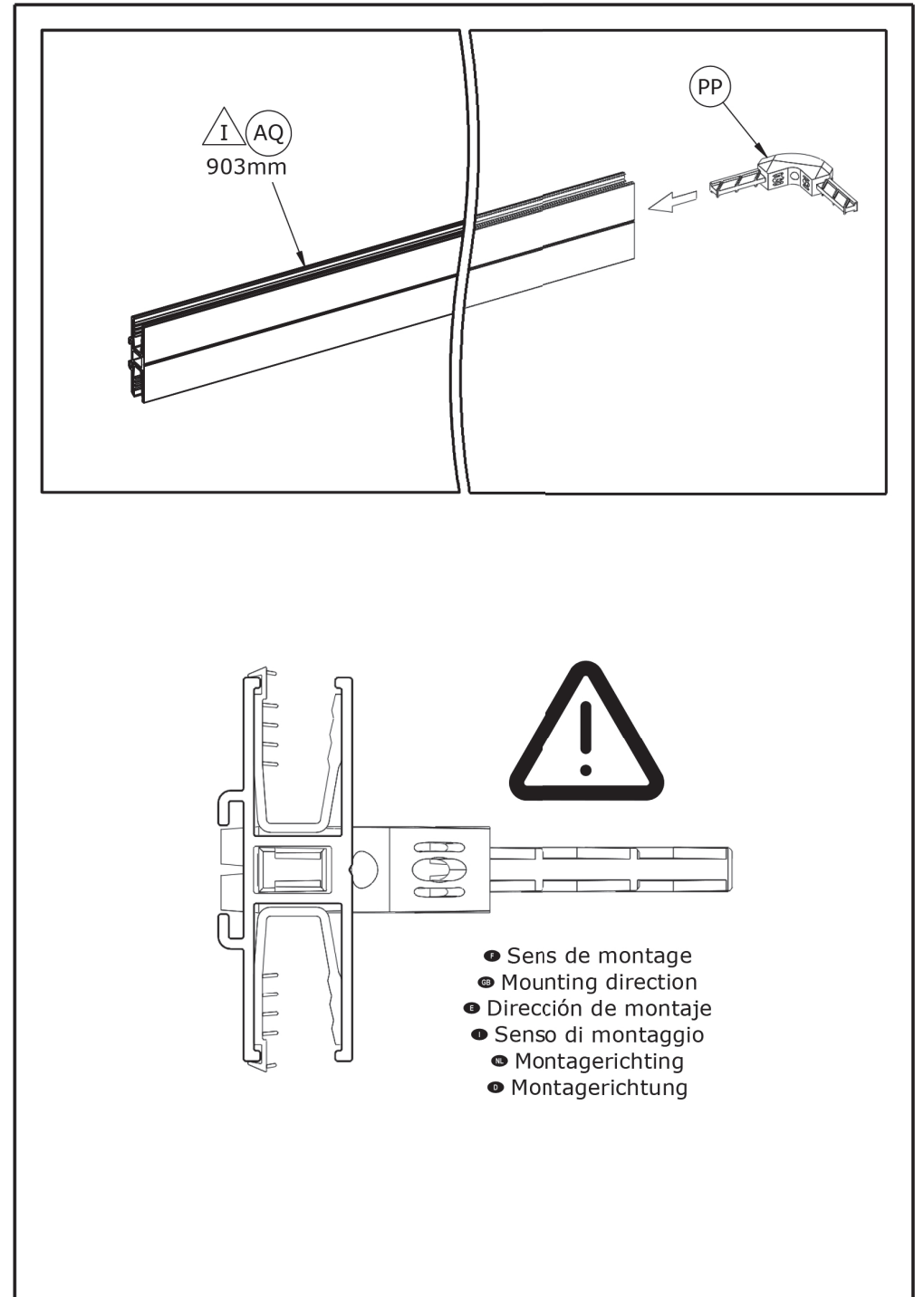
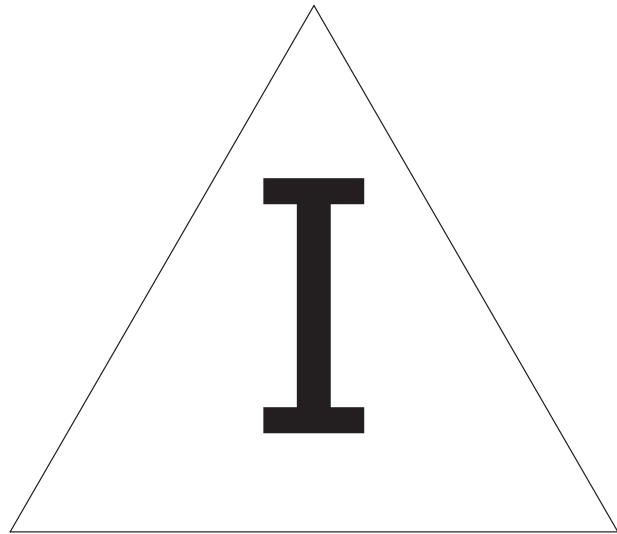

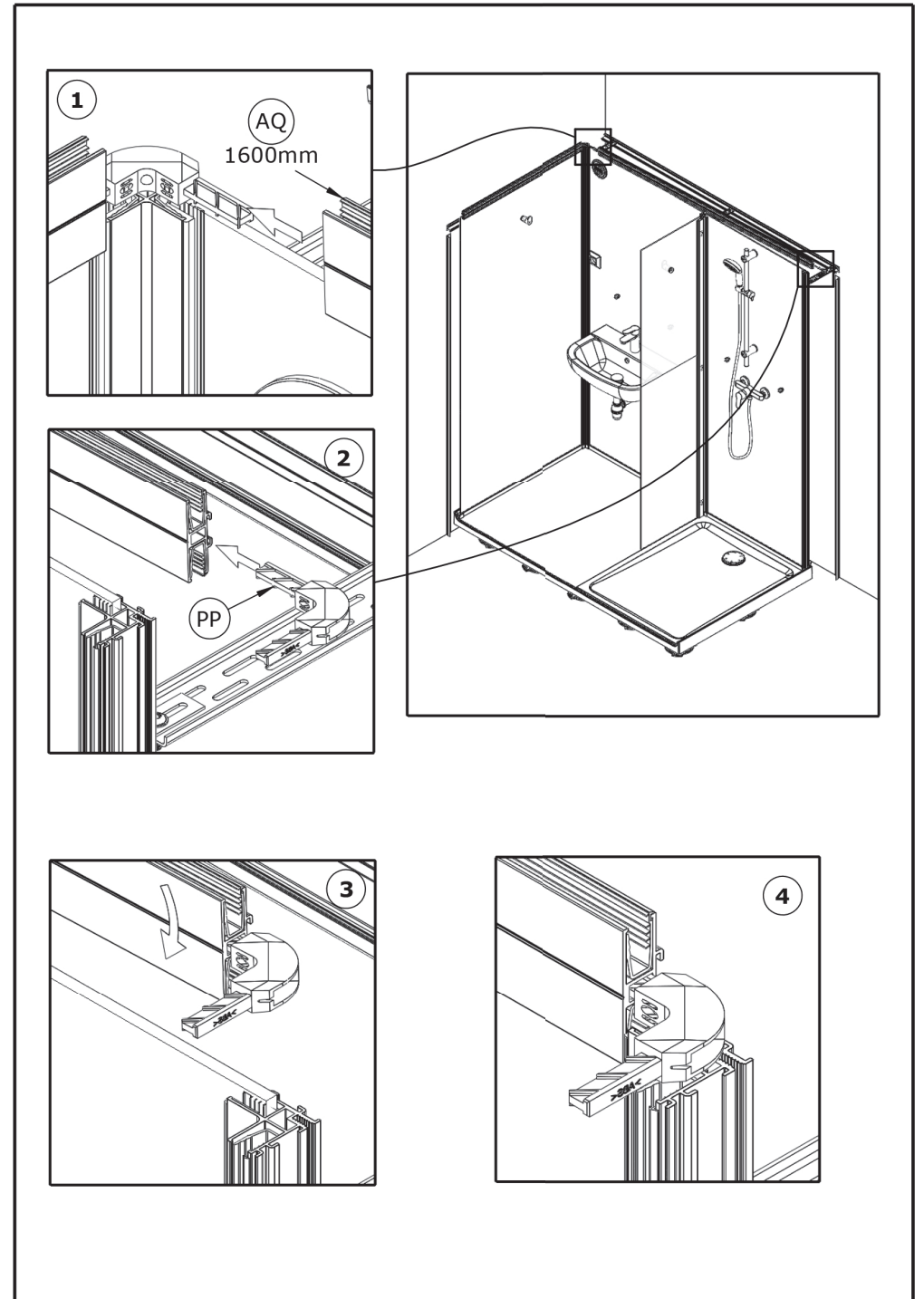
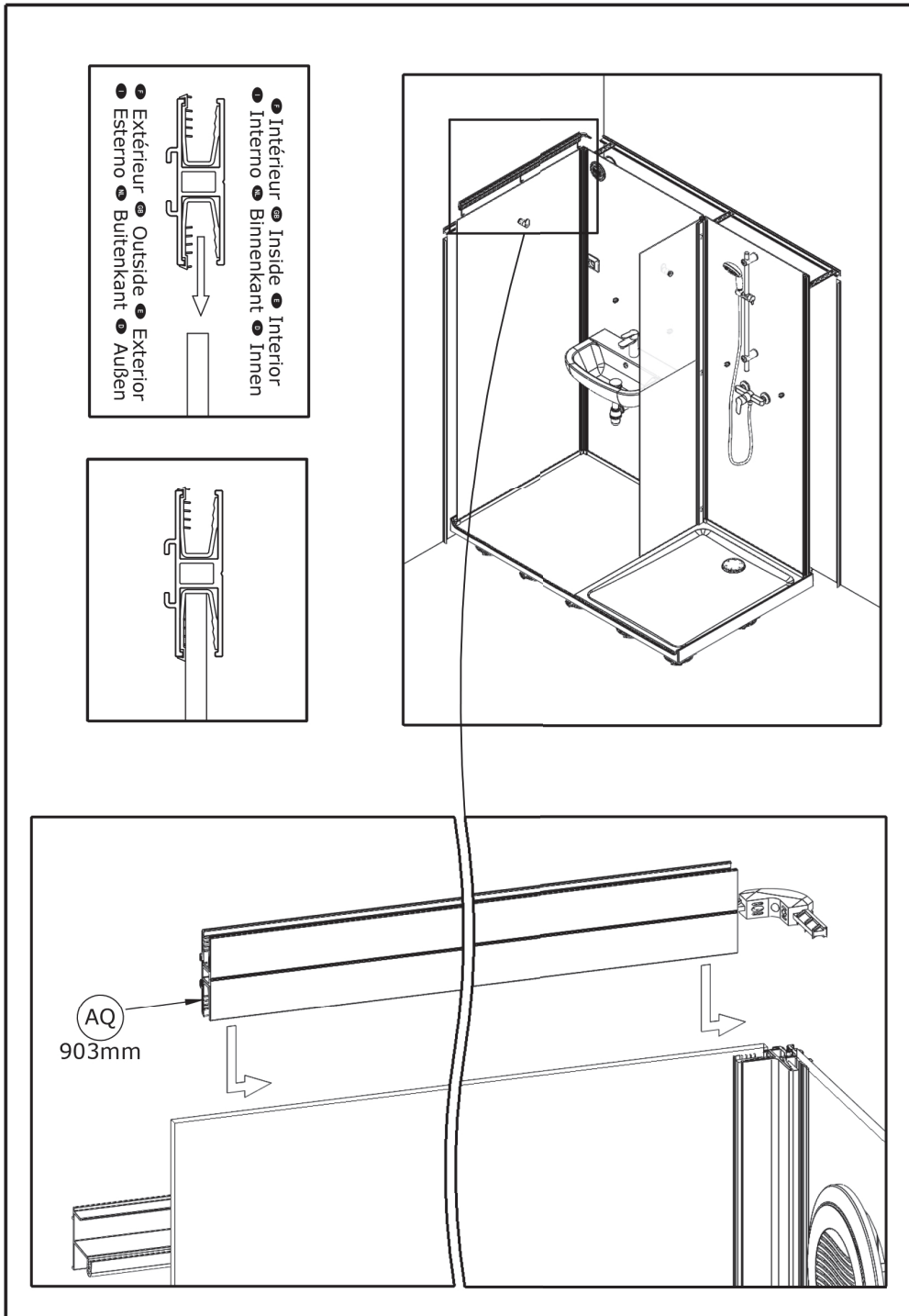

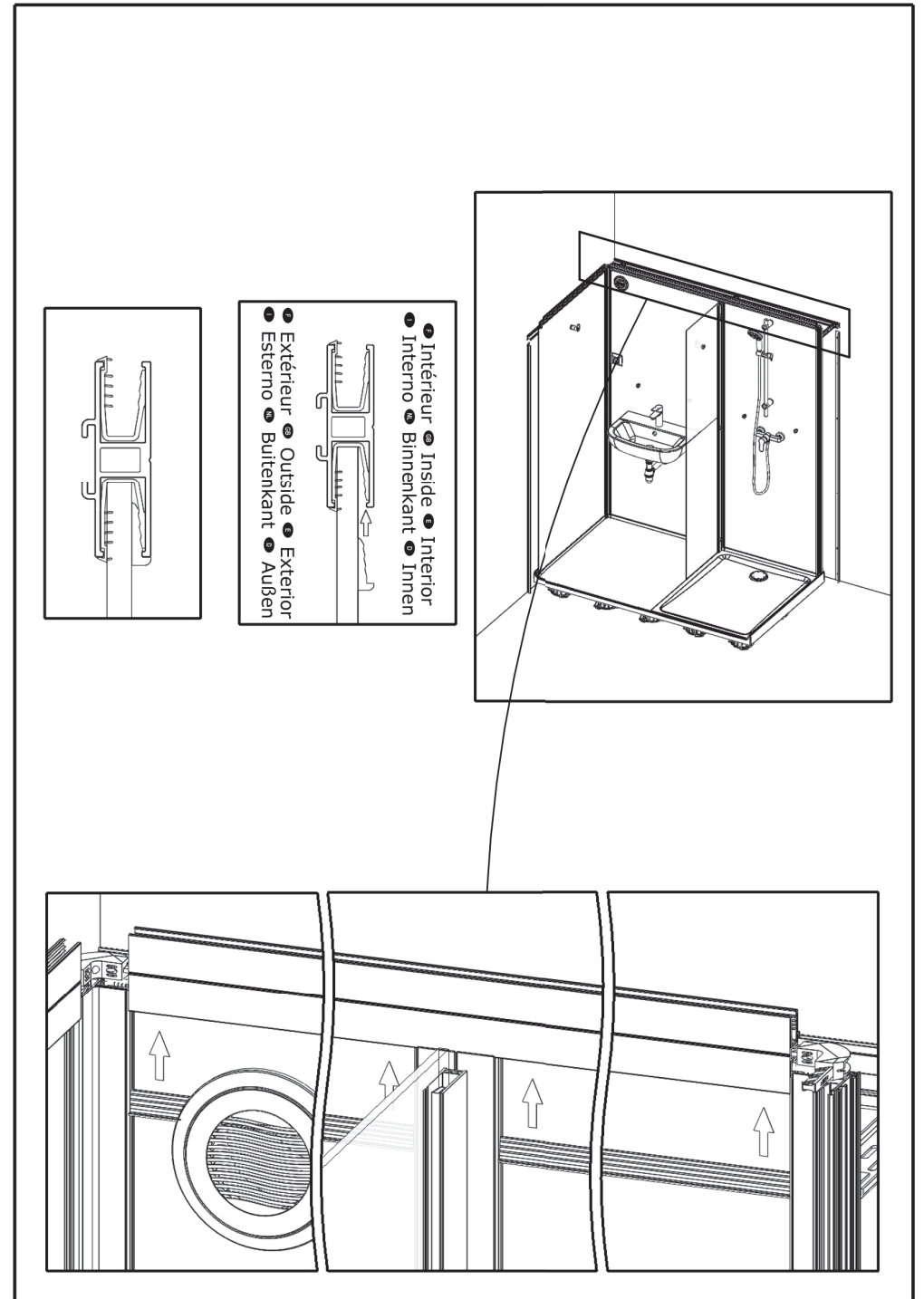
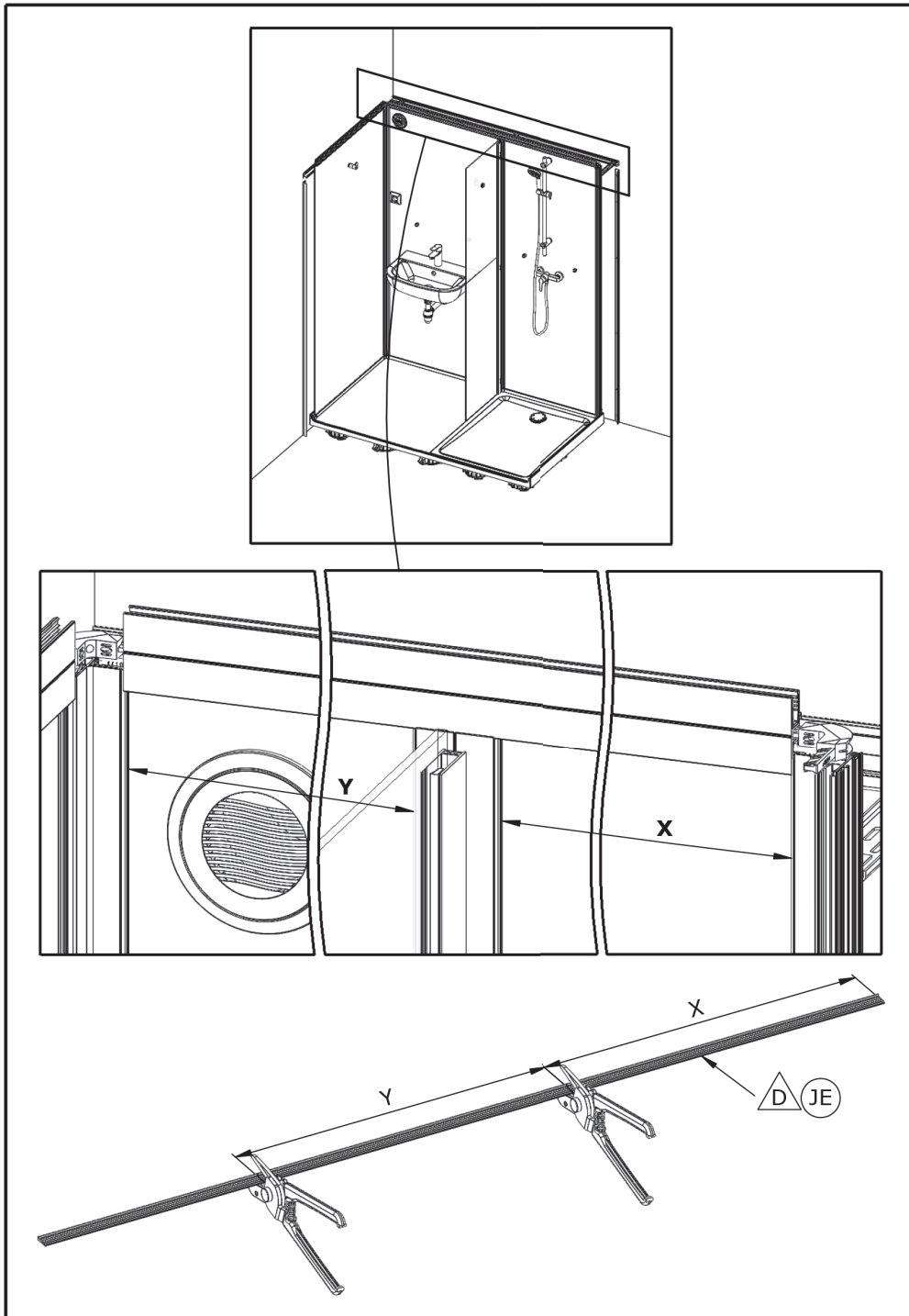

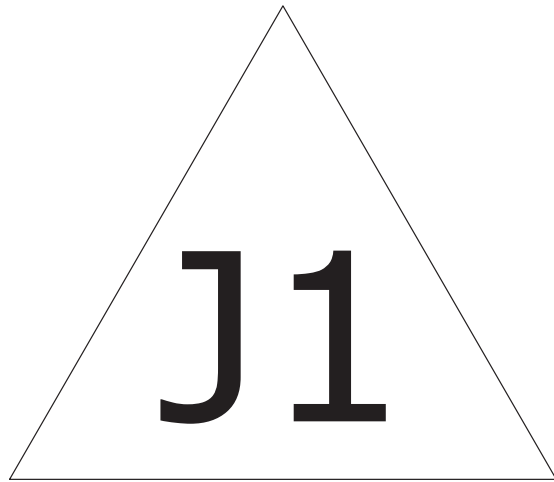

+

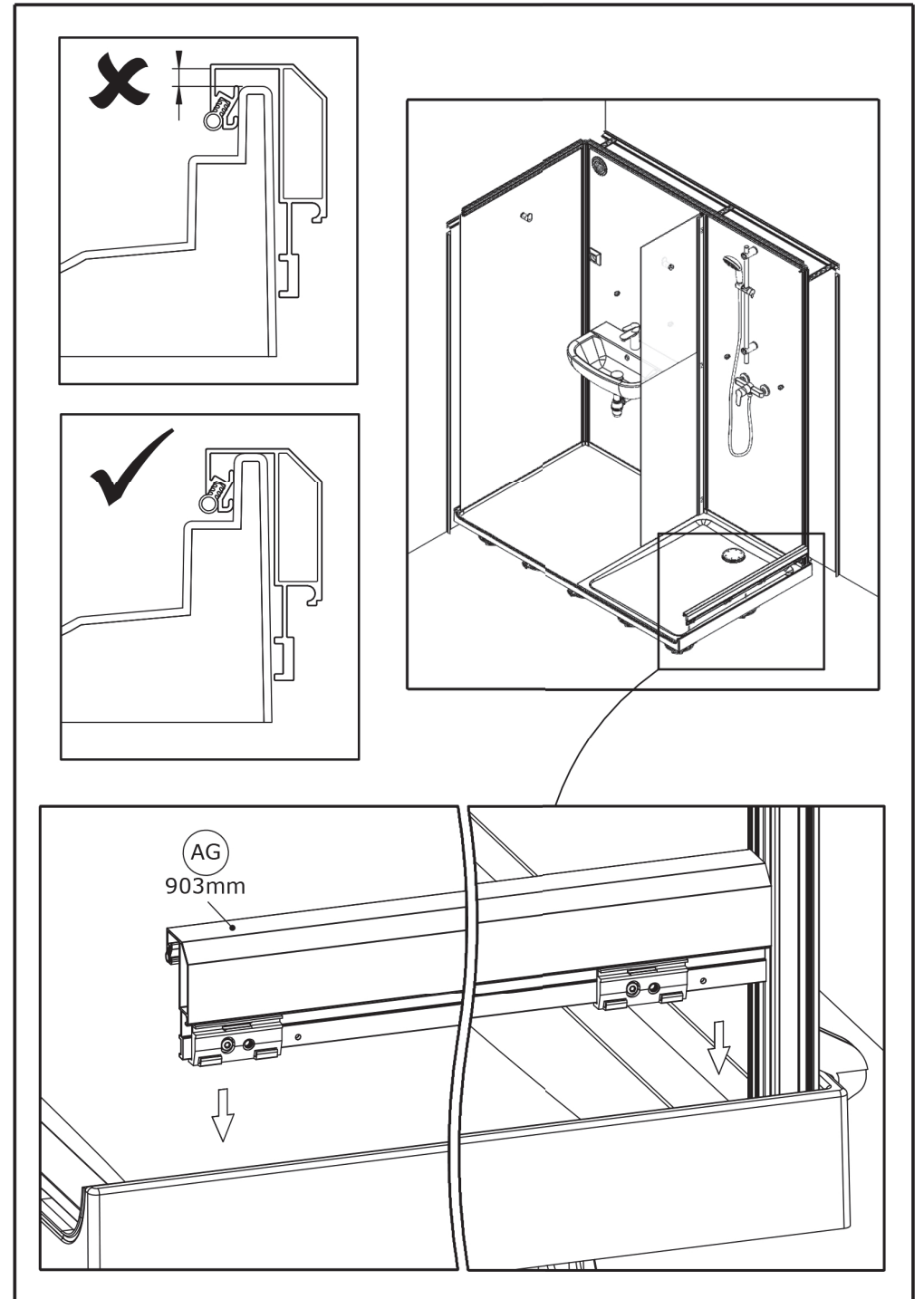
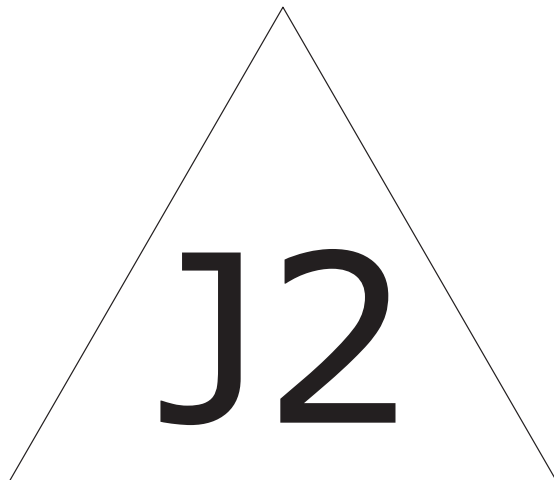

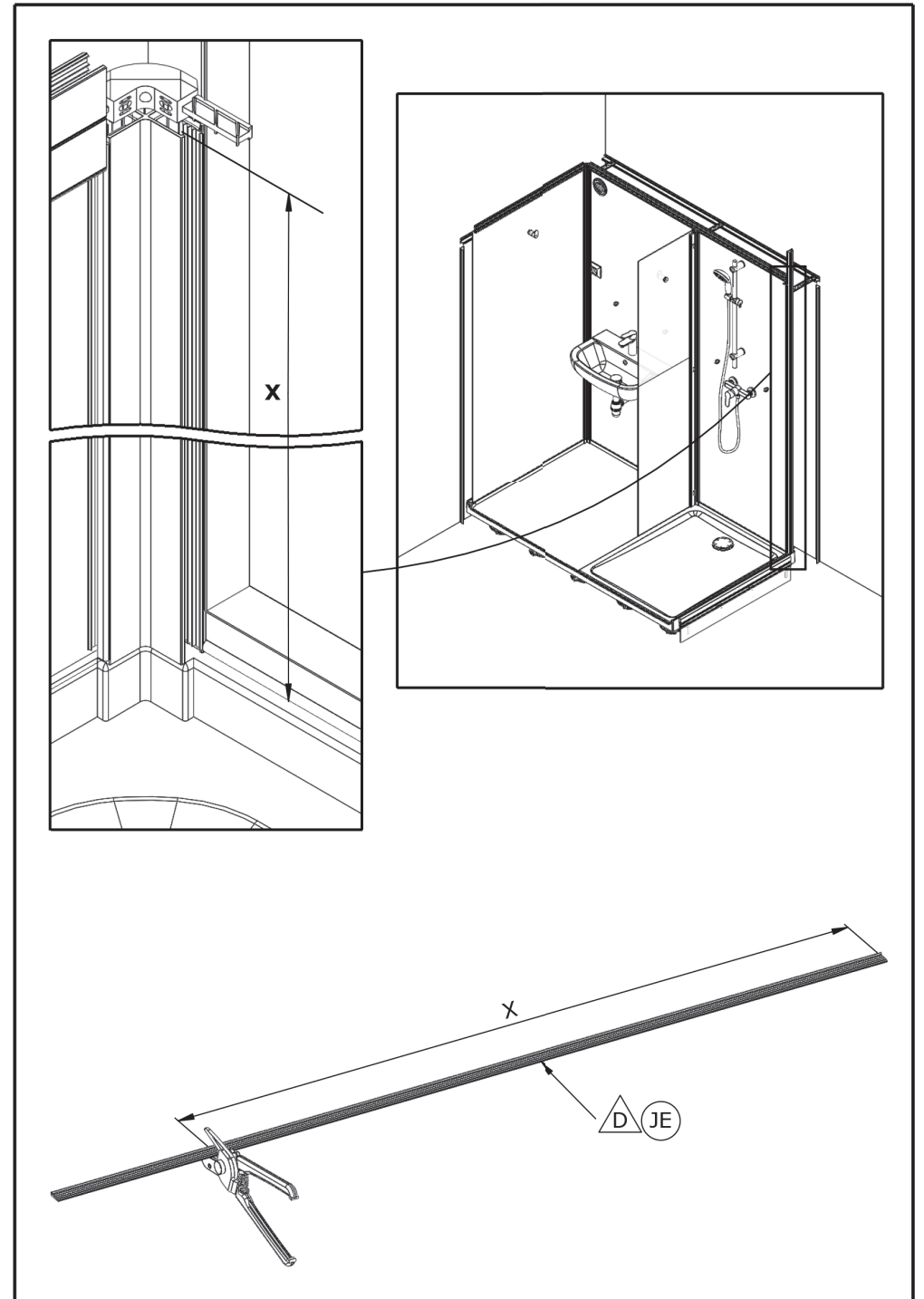
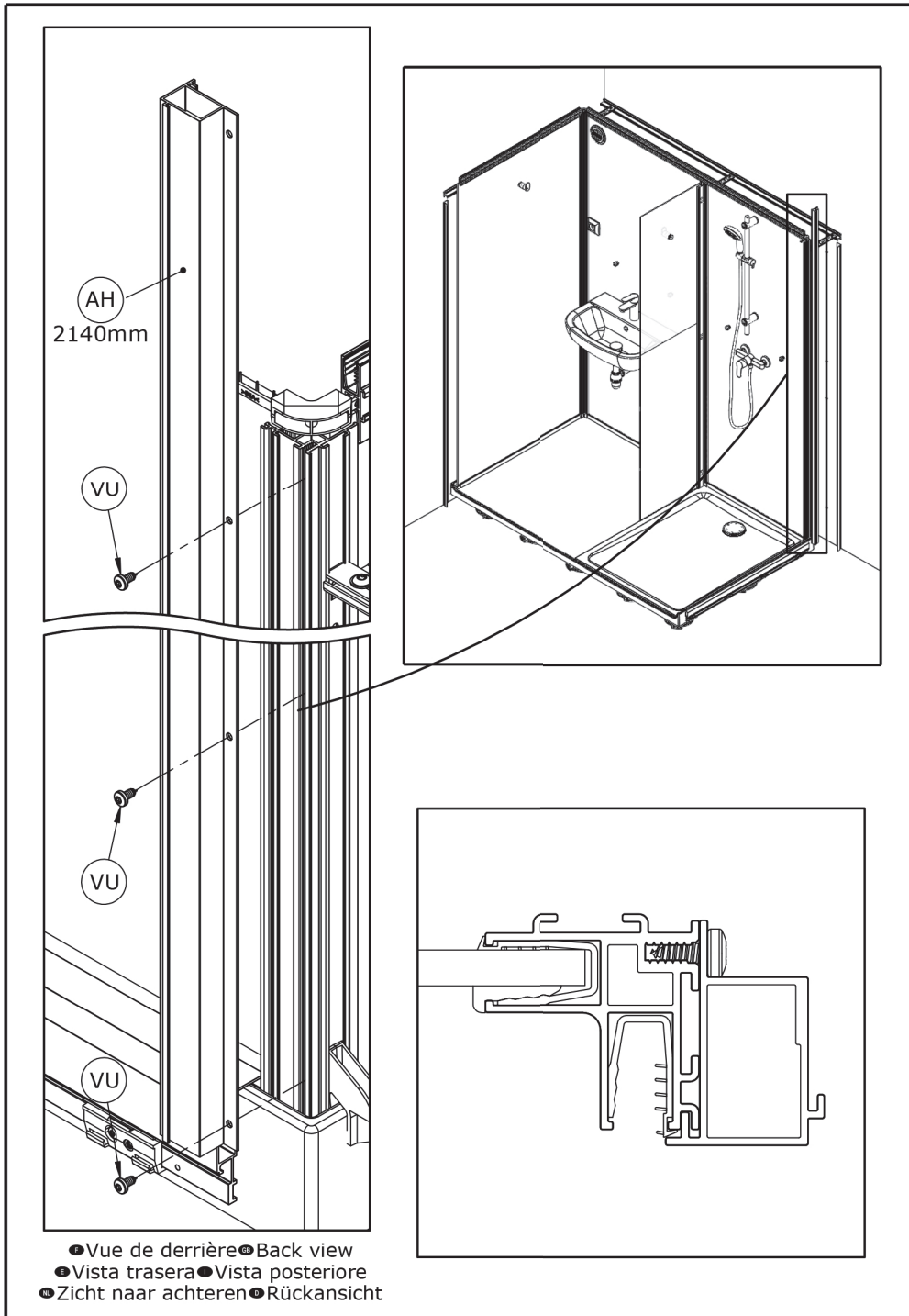

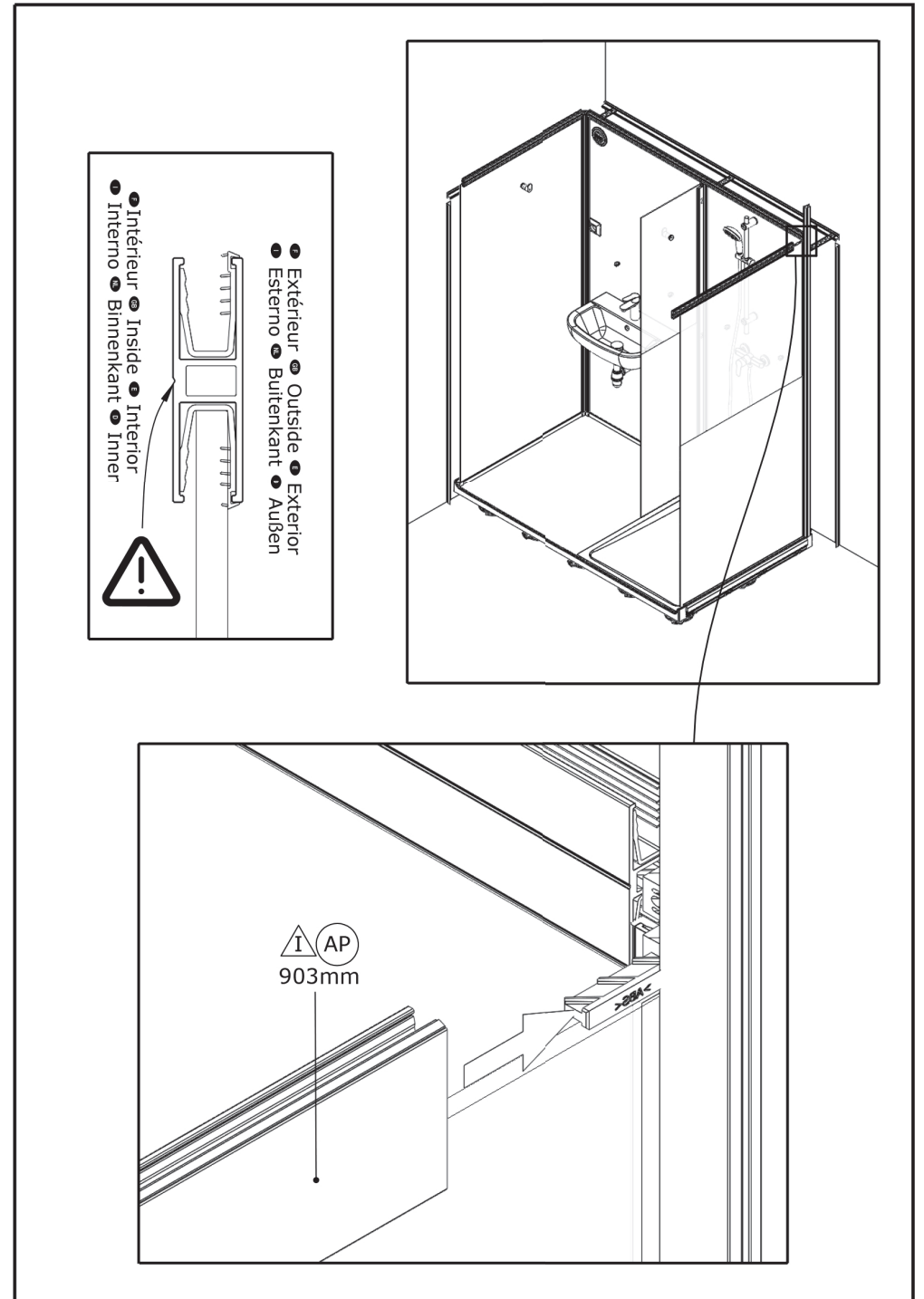
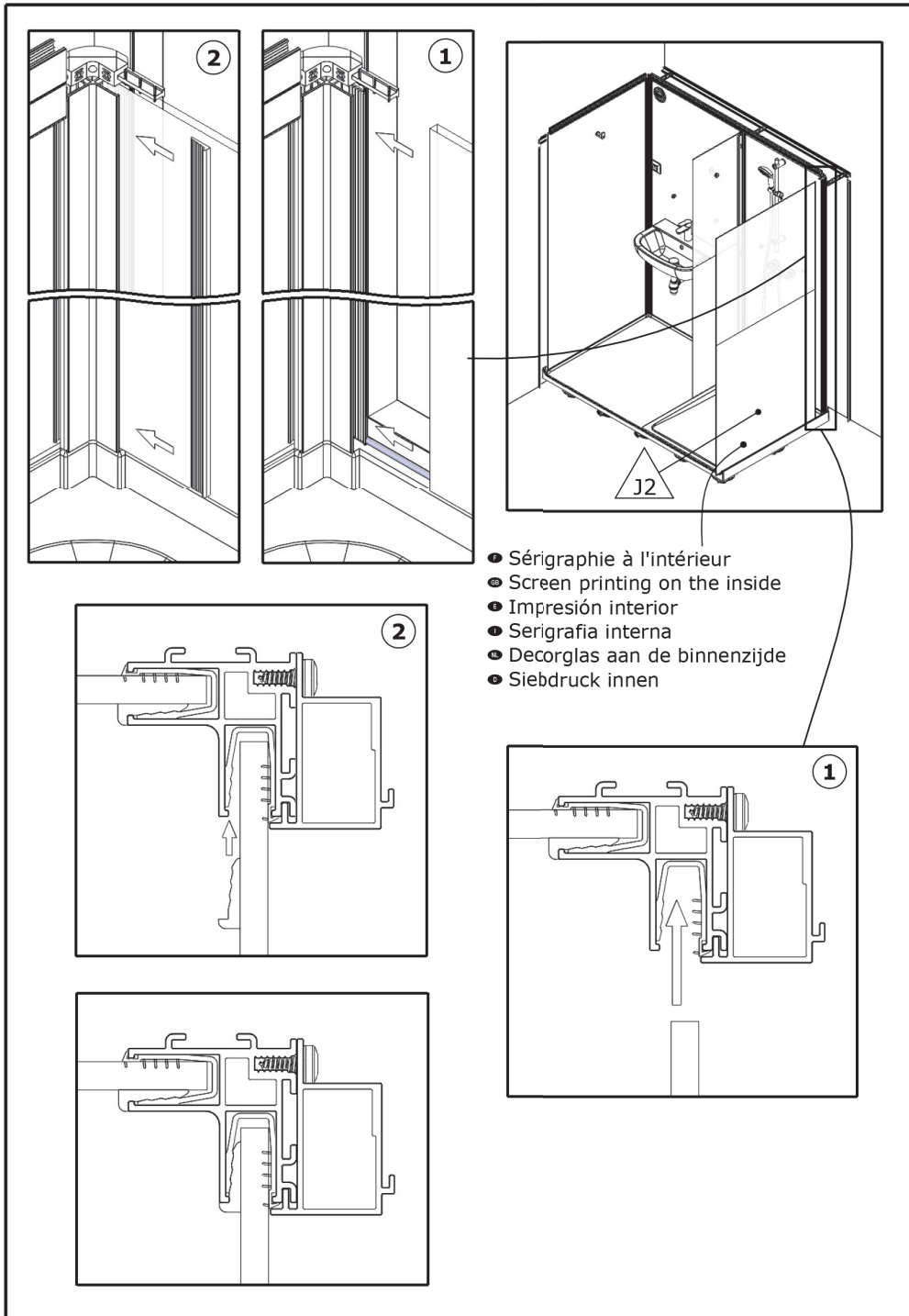

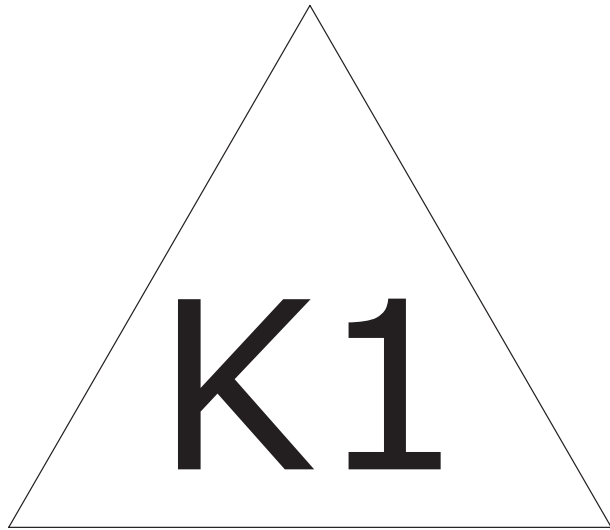

+

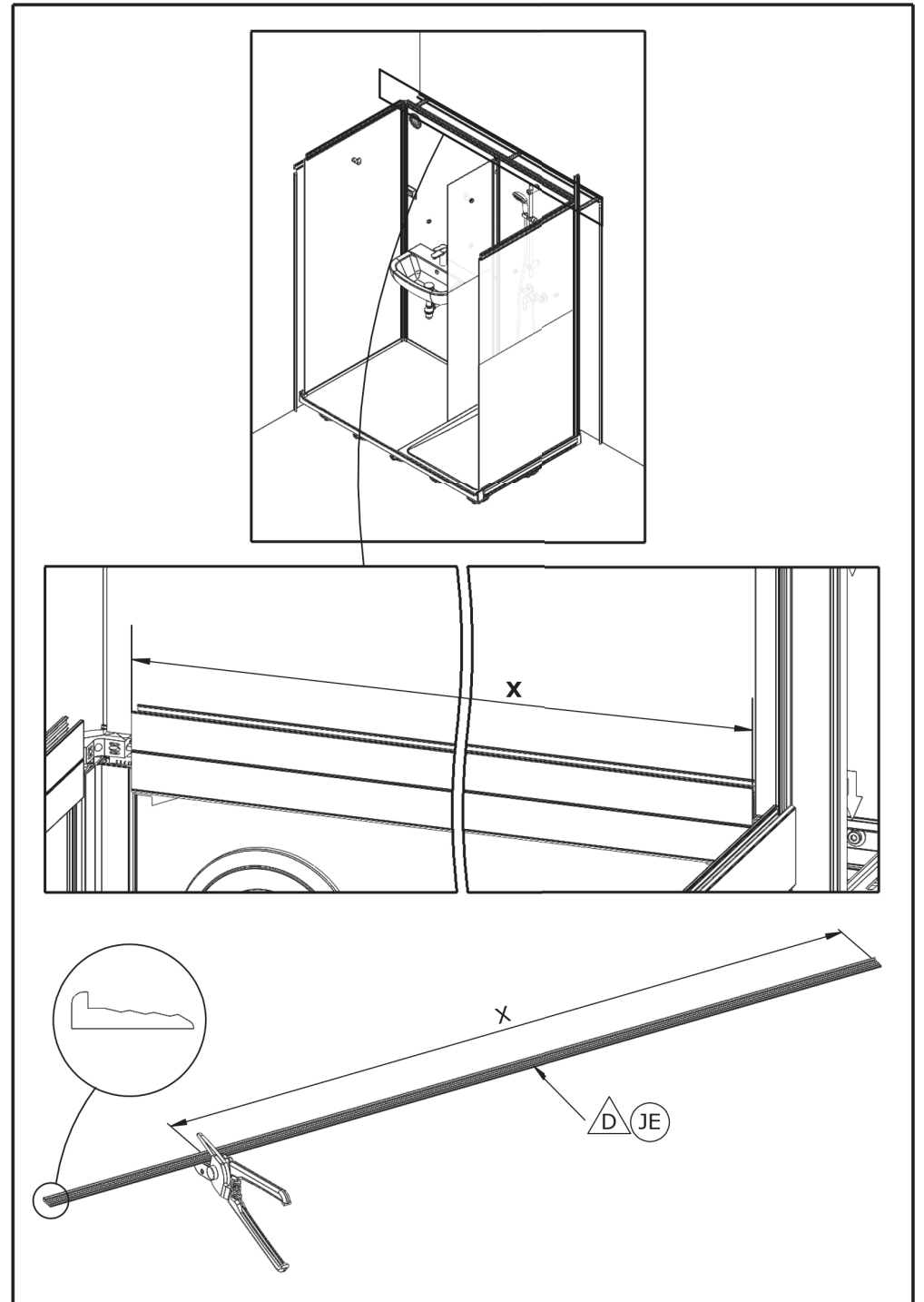
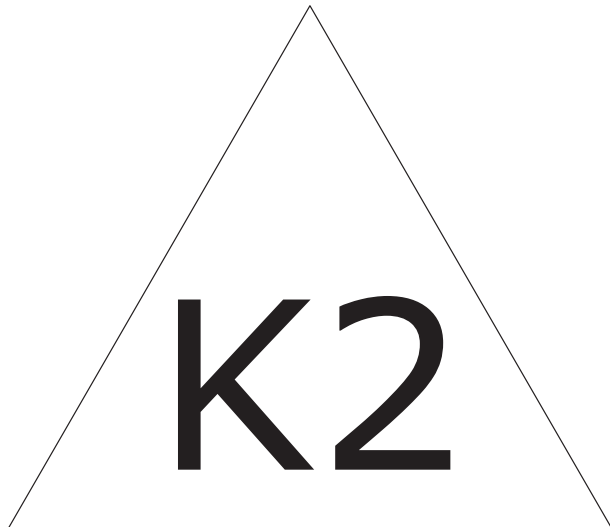

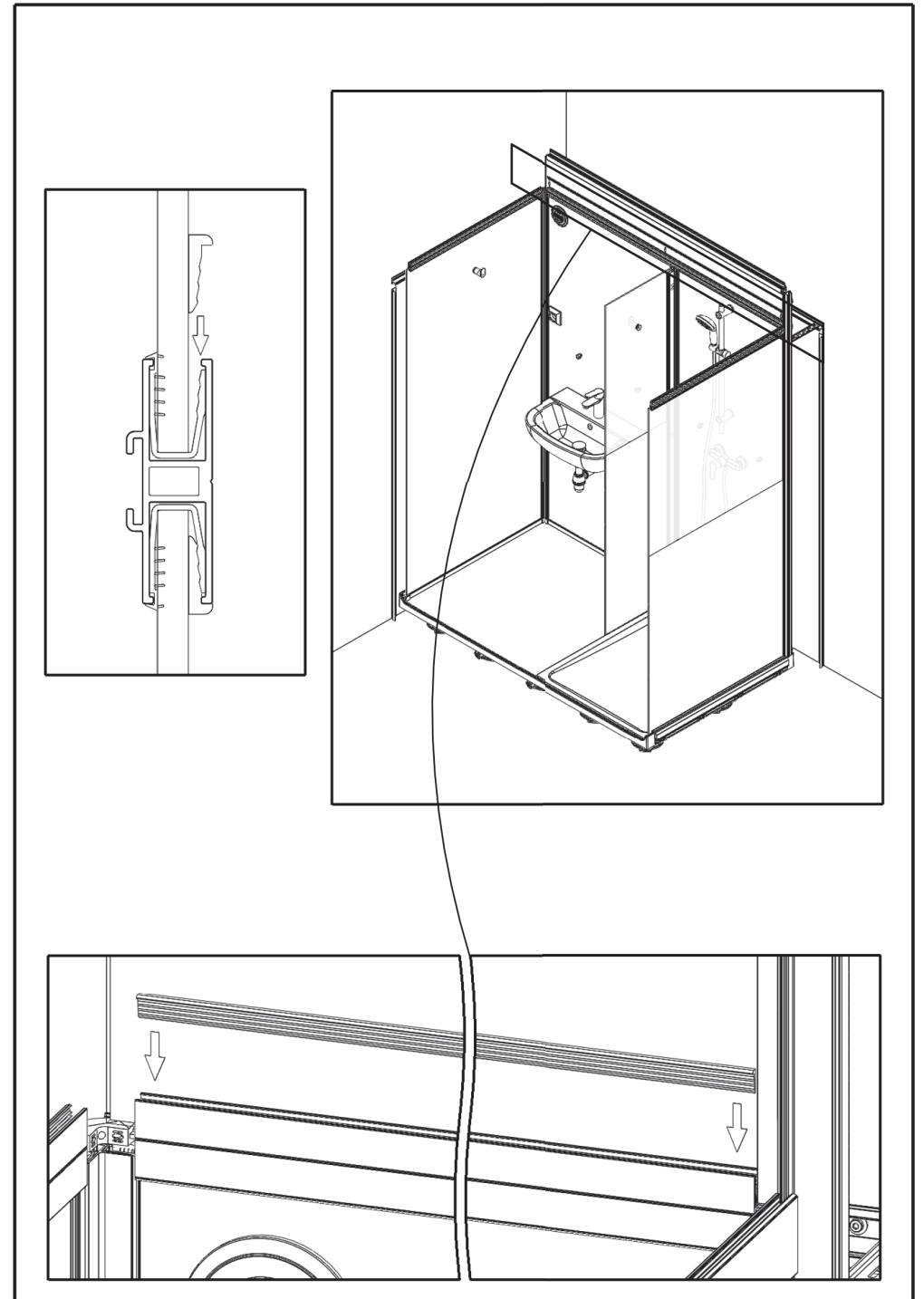
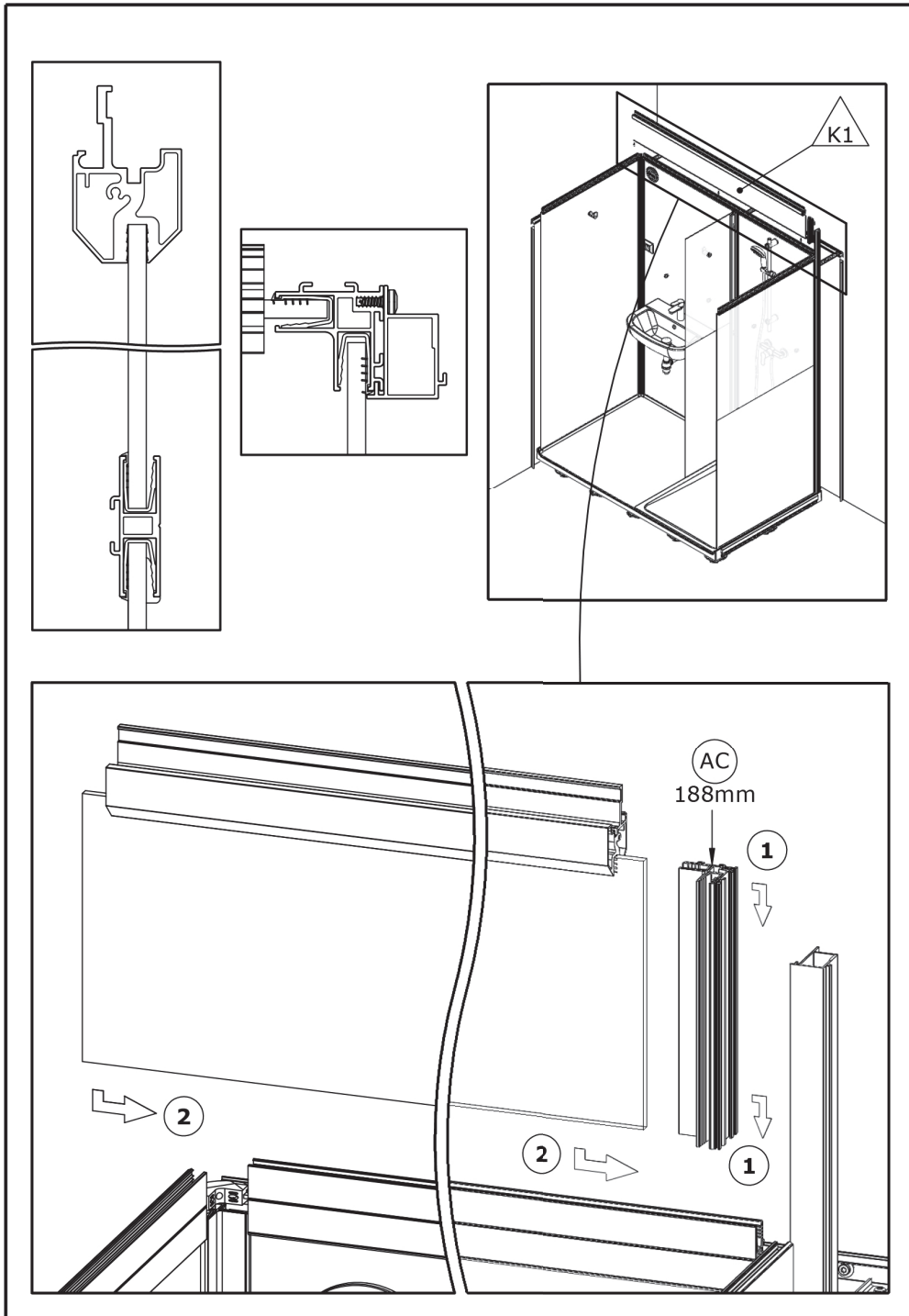

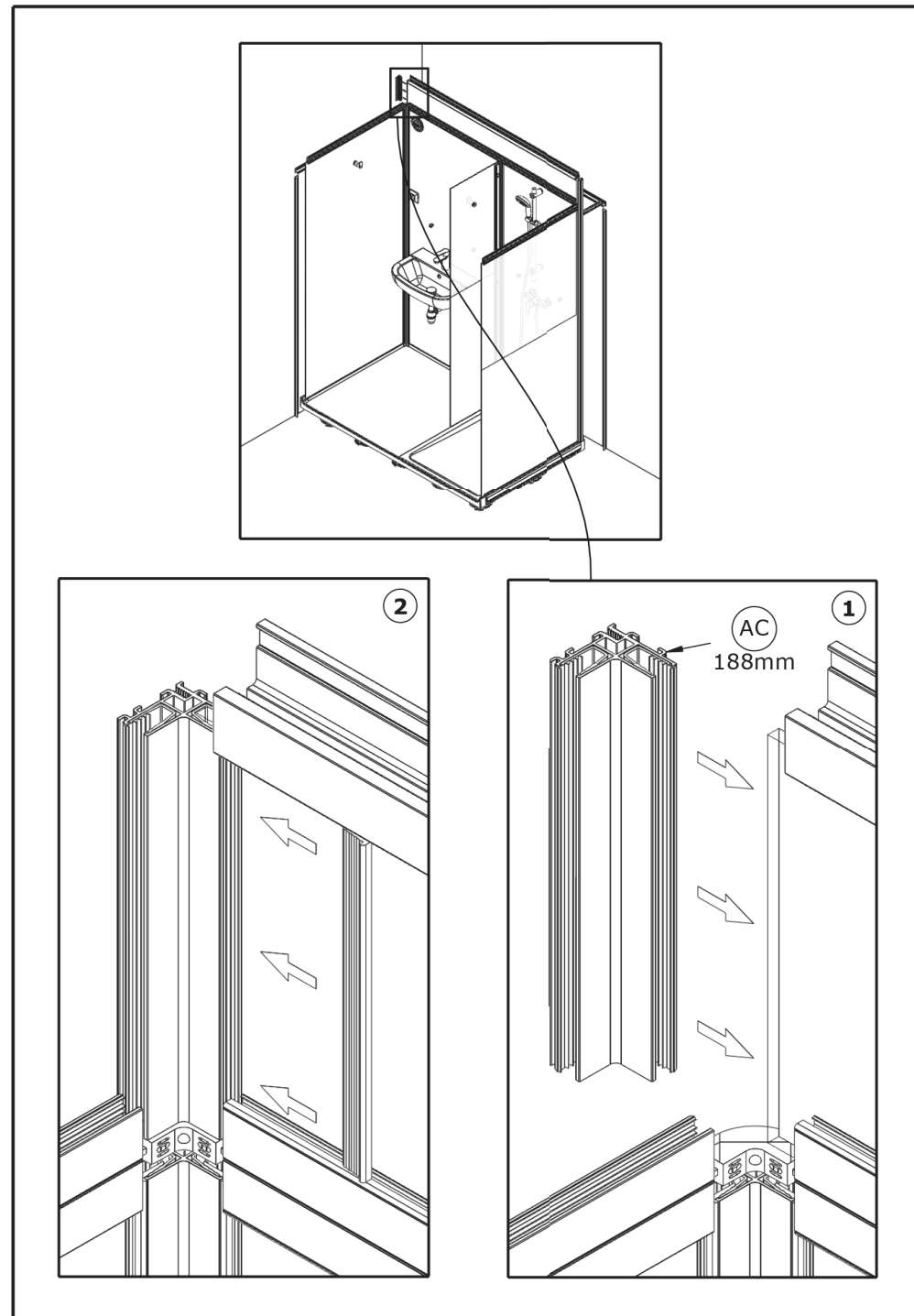
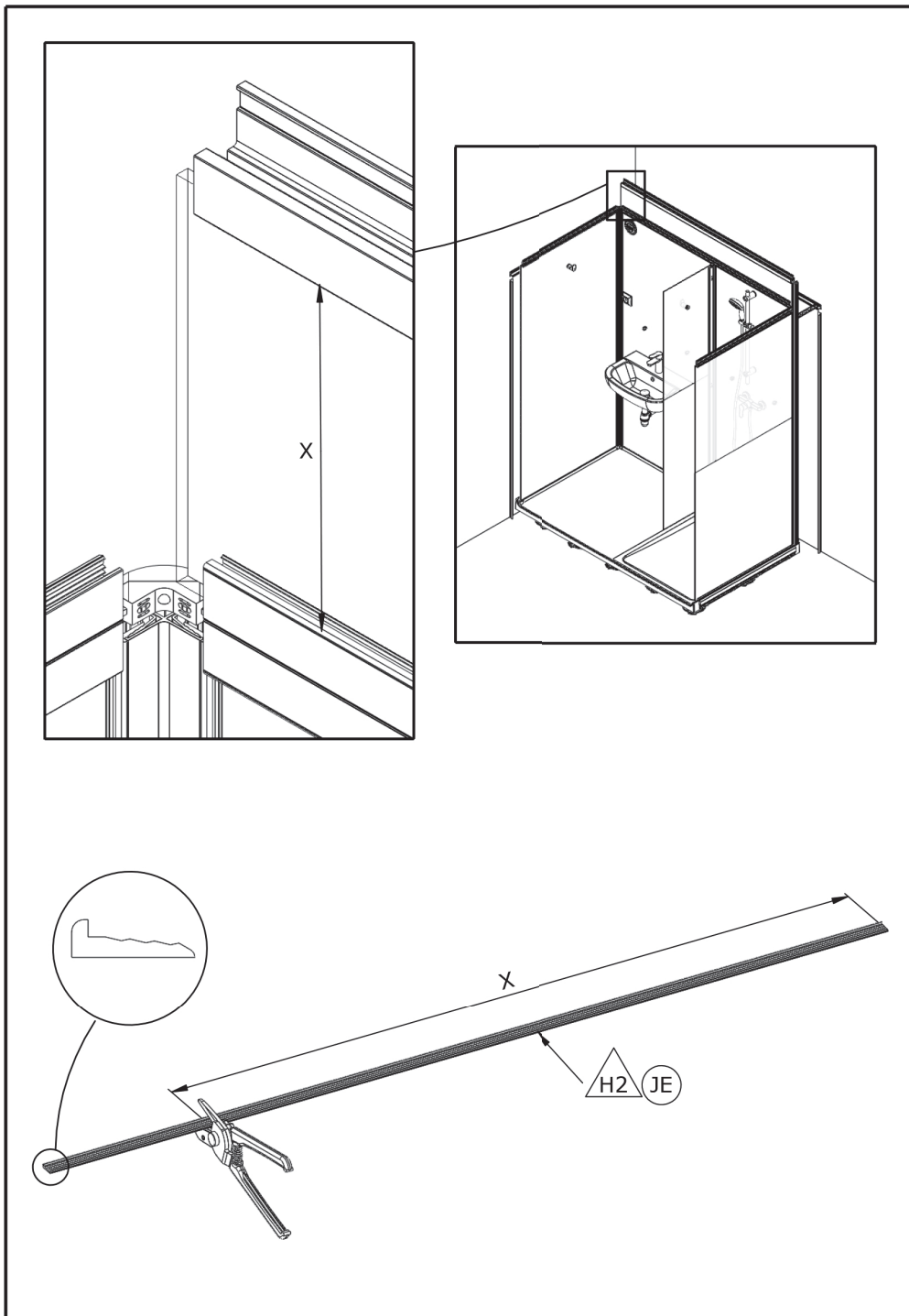

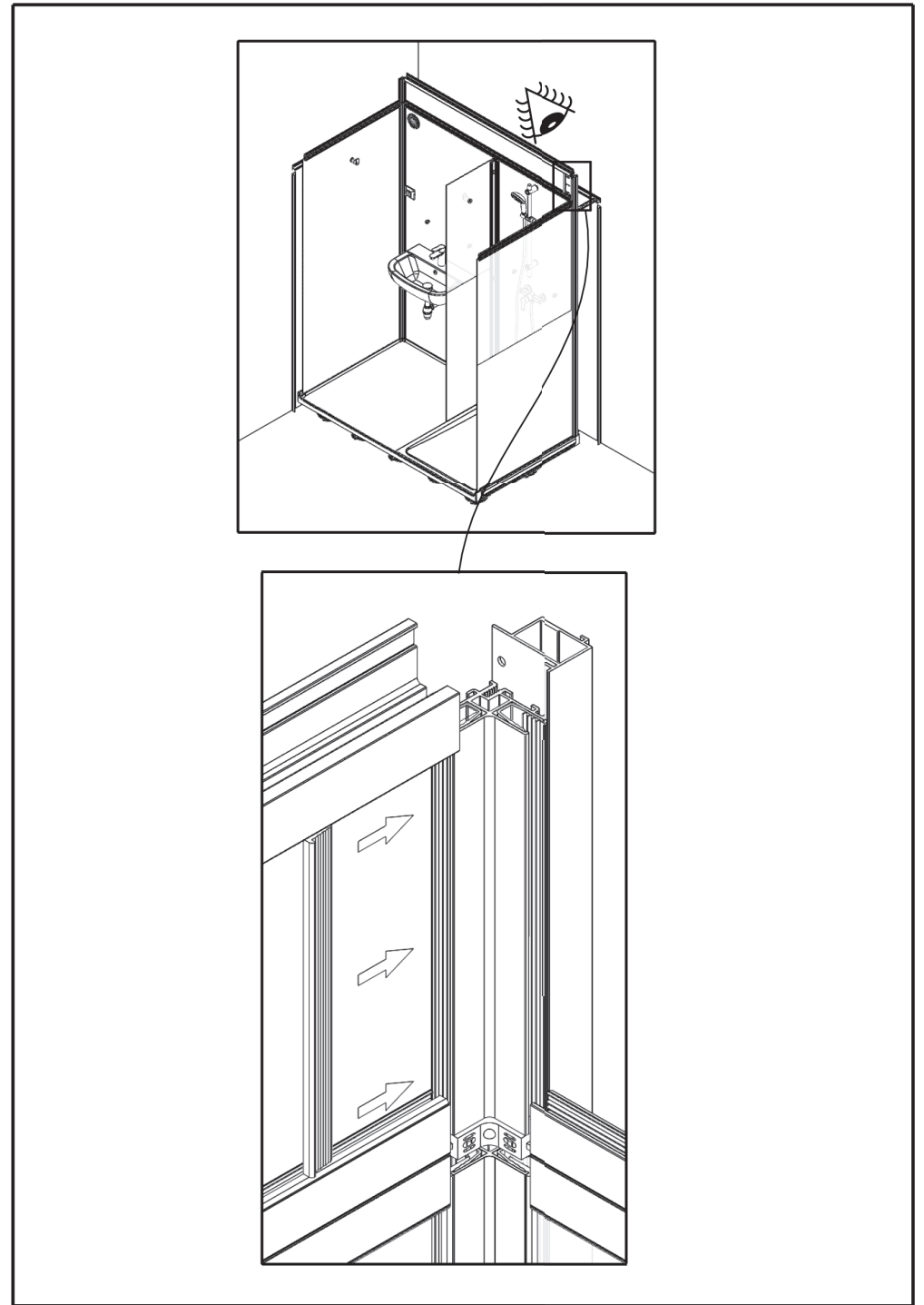
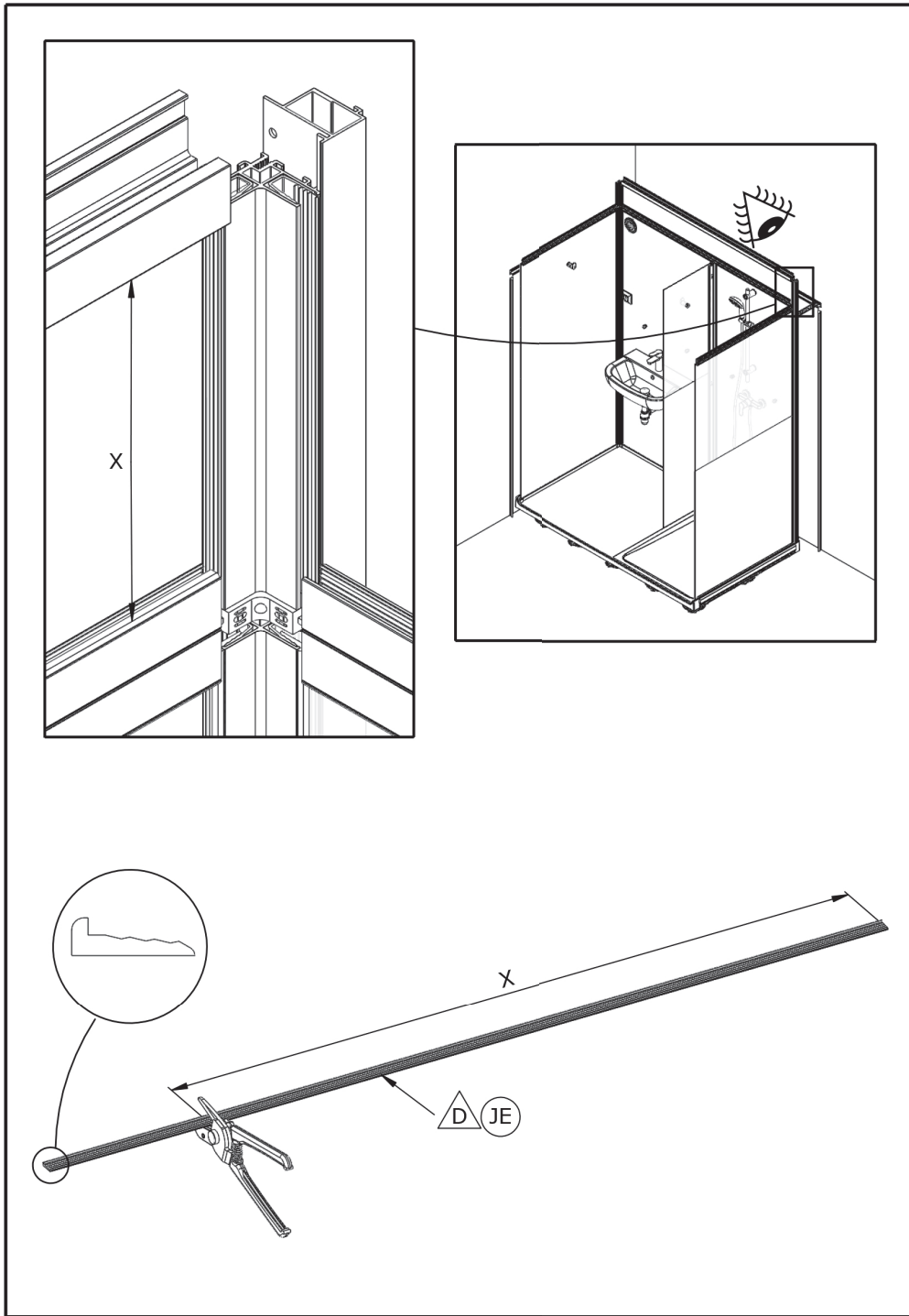

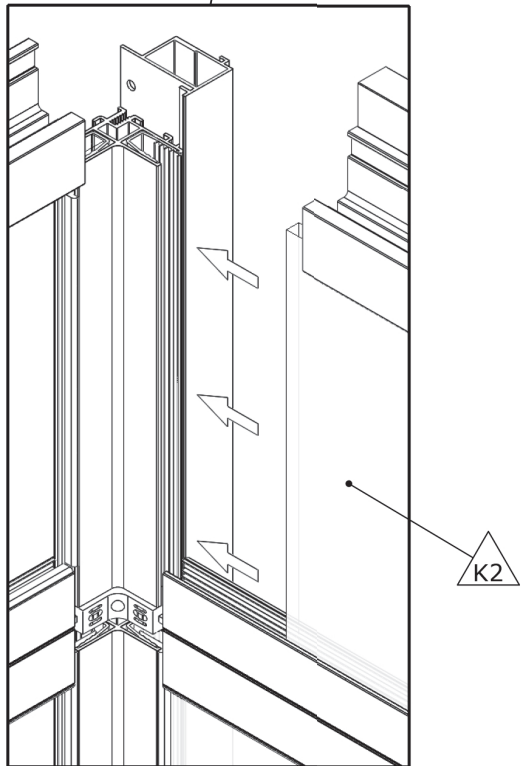
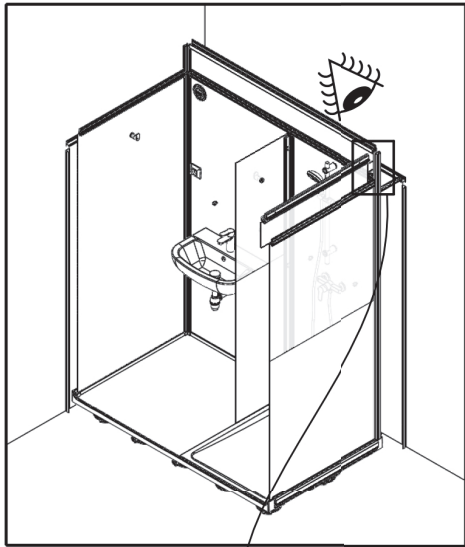

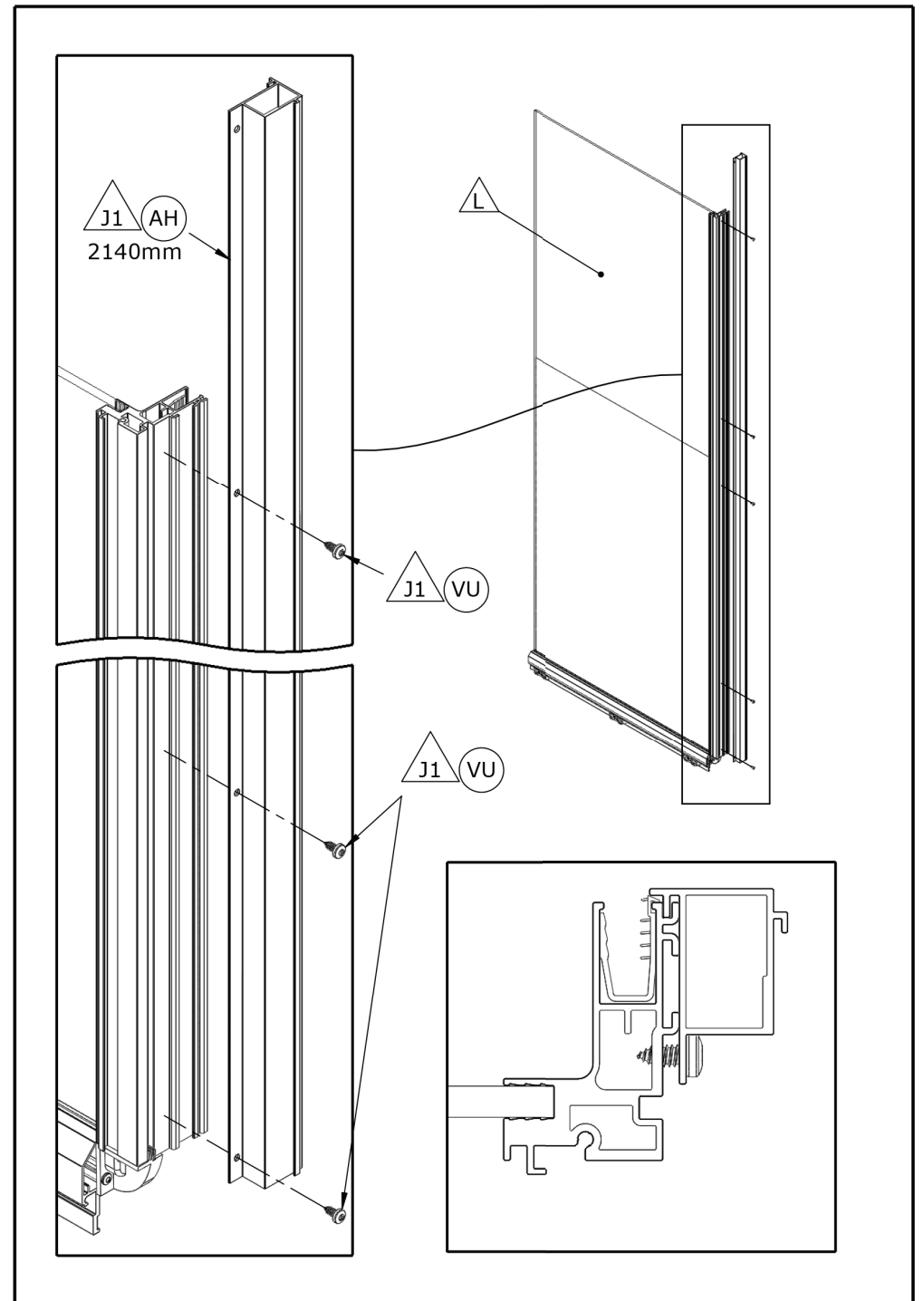
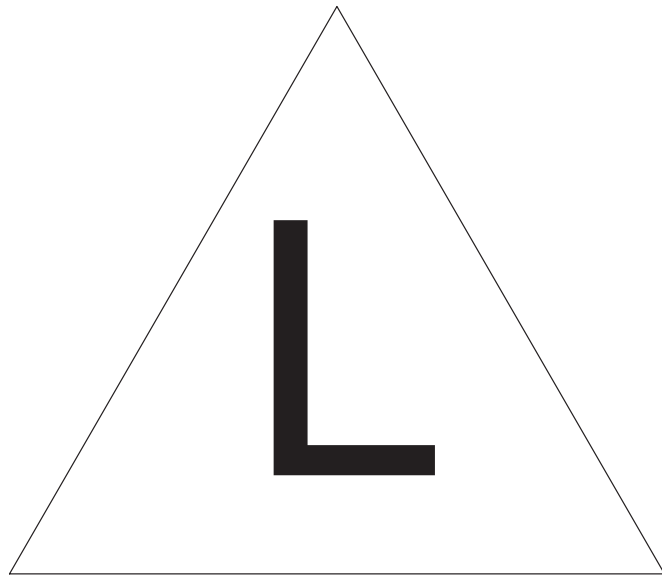

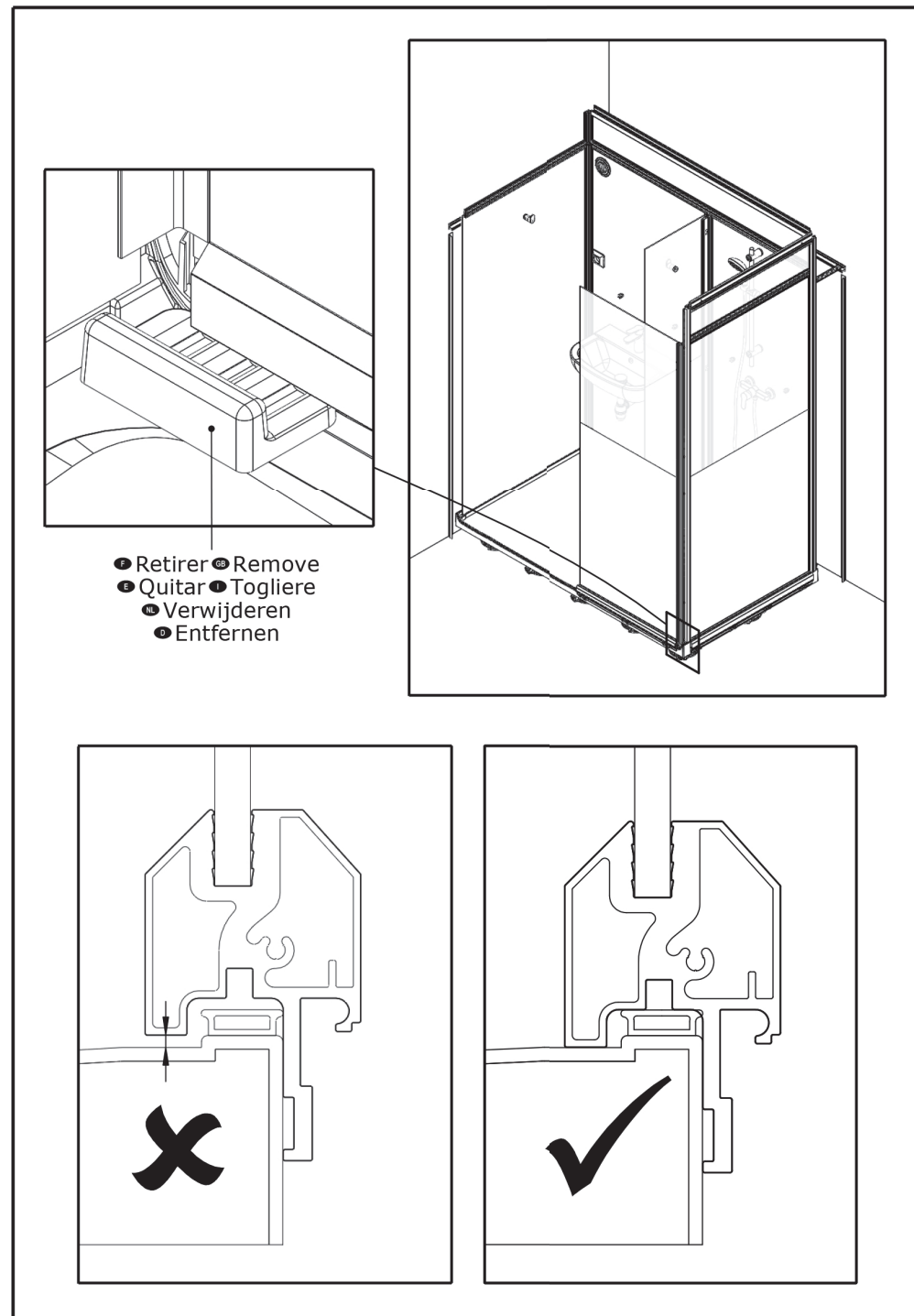
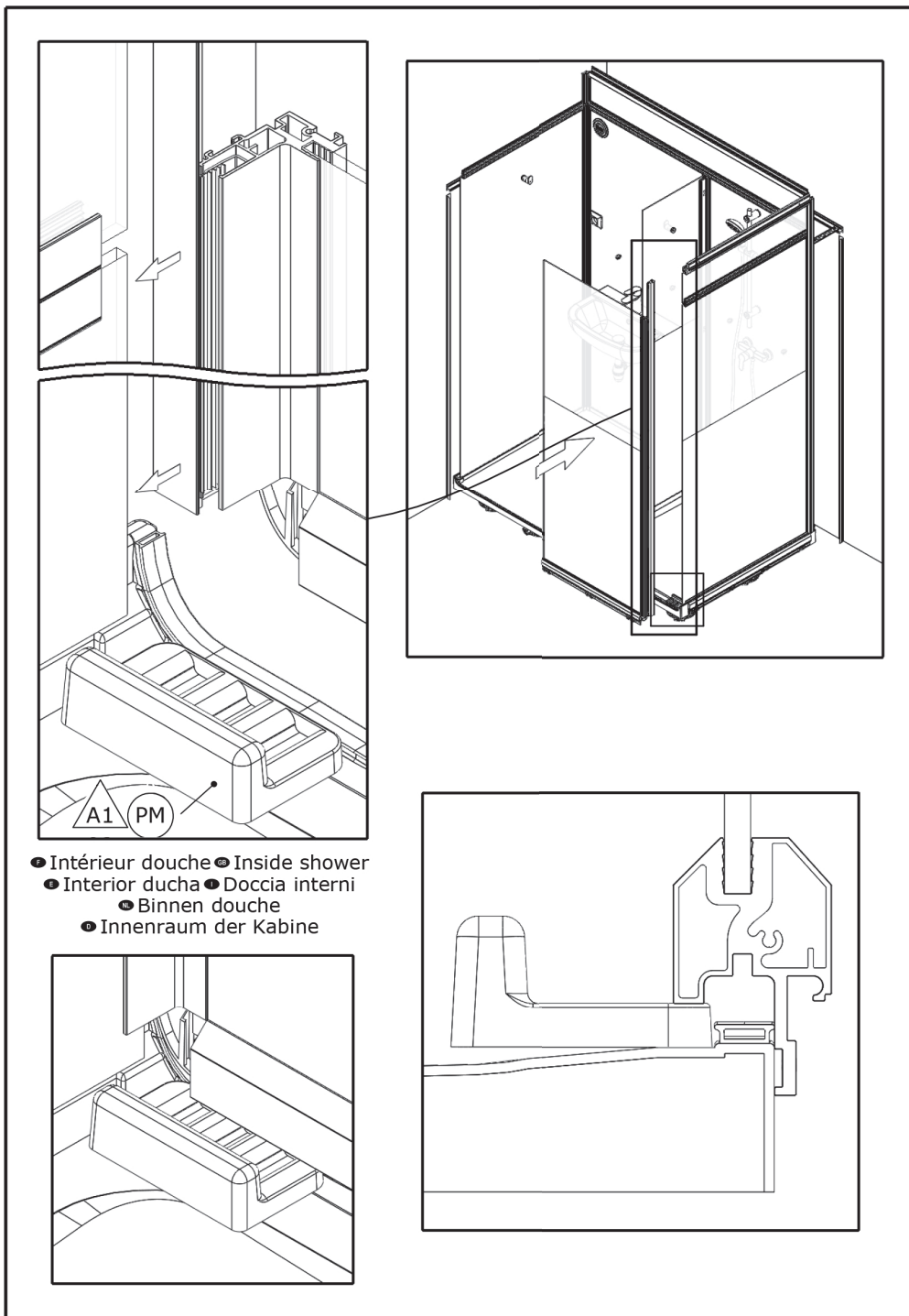

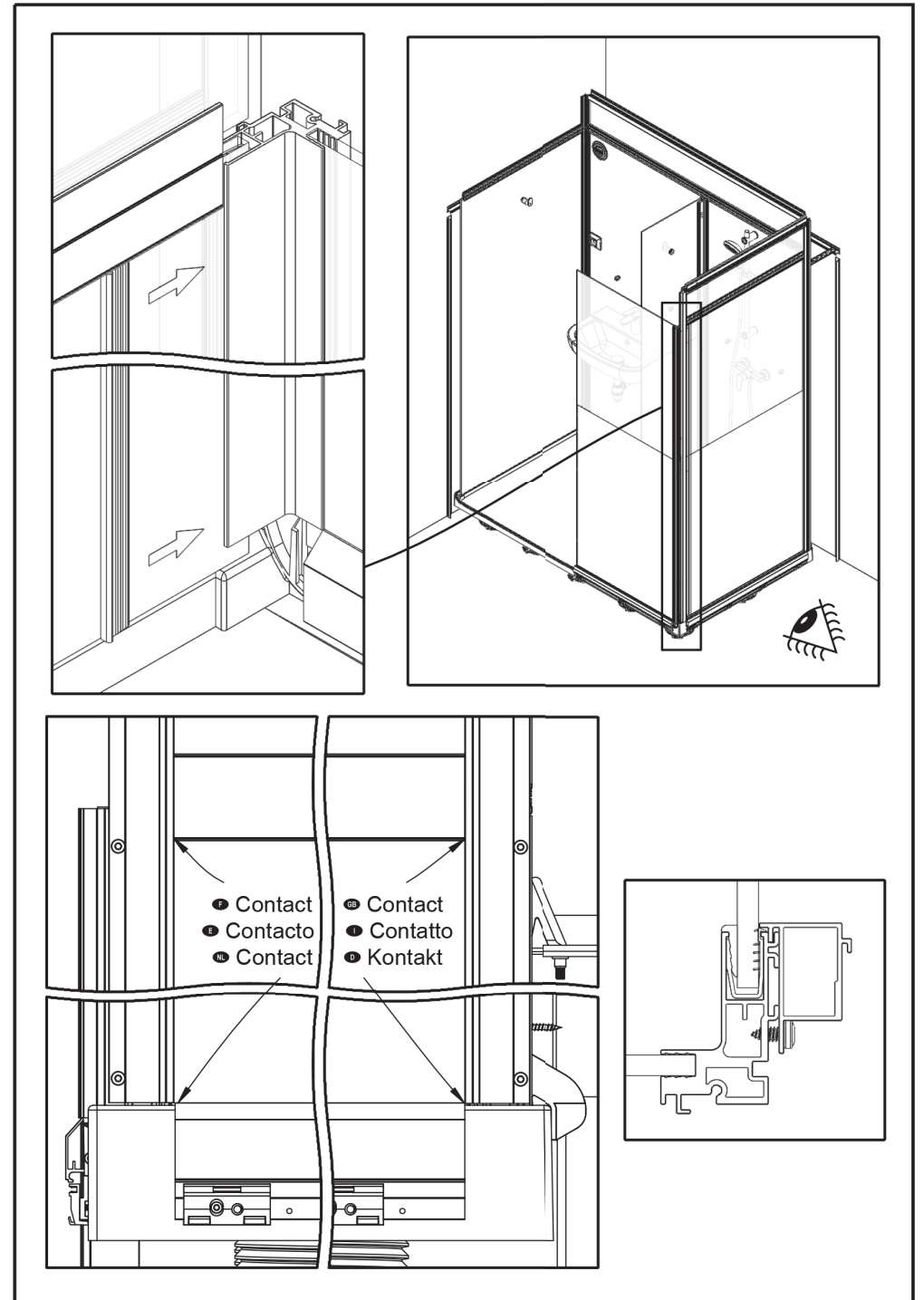
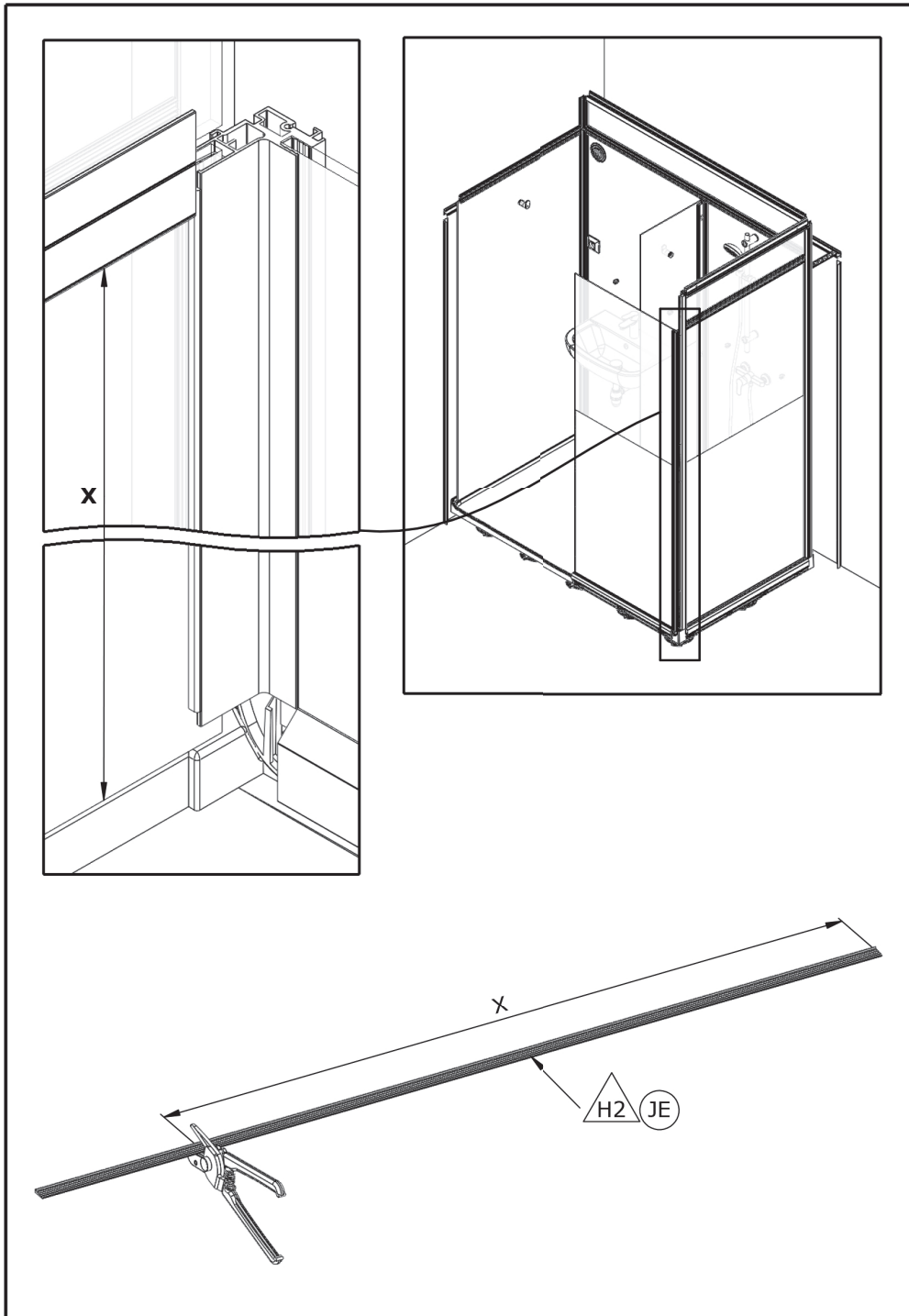

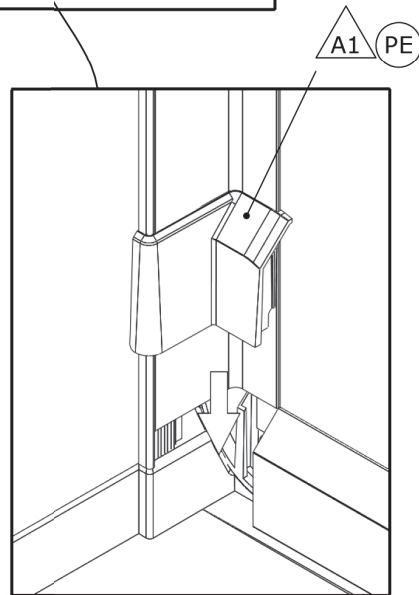
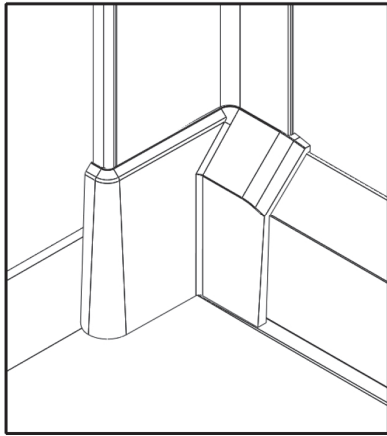
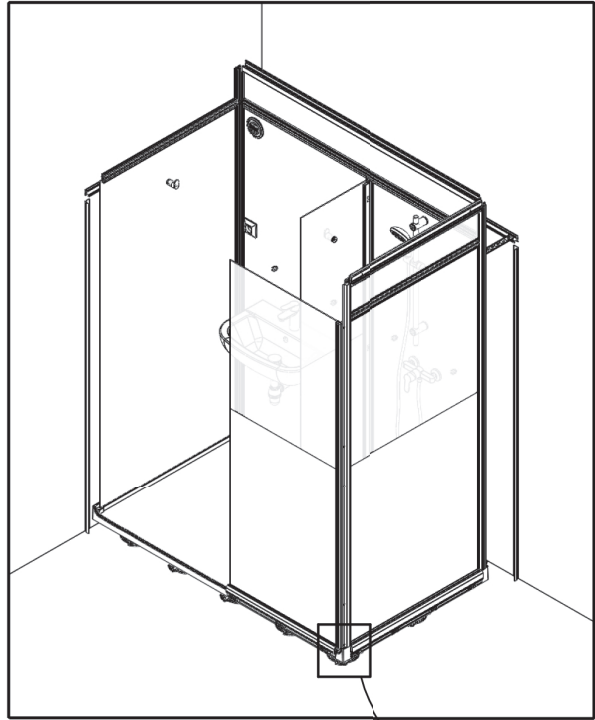

- Intérieur douche ● Inside shower
- Interior ducha ● Doccia interni
- Binnen douche ● Innenraum der Kabine



SAV
SERVICE HELPLINES
ASSISTENZA POST-VENDITA
SERVICIO POSTVENTA

FRANCE 02 40 21 29 45	SCHWEIZ (01) 748 17 44
UK 020 8842 0033	ESPAÑA 93 544 60 76
IRELAND 04697 33102	NEDERLAND +31 475 487 100
DEUTSCHLAND +49 (0) 6074 / 30928 0	BELGIË +31 475 487 100
ITALIA (0382) 6181	BELGIQUE +31 475 487 100
ÖSTEREICH +43 1 710 60 70	РОССИЯ 963 19 40, 773 67 22