

Notre service technique est à votre écoute aux numéros qui sont au dos de cette notice d'installation

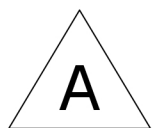



NE BRANCHER L'APPAREIL ÉLECTRIQUEMENT QU'APRÈS SON INSTALLATION COMPLÈTE



L'installation doit être réalisée par une personne qualifiée et l'installation doit se conformer aux normes en vigueur dans le pays d'utilisation (NF C15-100 pour la France)

- Si un câble est endommagé, il doit être remplacé par le fabricant ou son Service Après-Vente afin d'éviter un danger.
- Les appareils de Classe I doivent obligatoirement être raccordés à une prise 2 pôles + terre.
- Tous les circuits électriques de ce produit doivent être raccordés à un dispositif différentiel 30 mA.
- Avant toute intervention sur l'installation électrique, s'assurer que cette dernière n'est pas sous tension.
- Réaliser une liaison équipotentielle conformément à la norme en vigueur dans le pays :
 - tuyaux métalliques (NF C15-100 pour la France)
 - fixation murale si cette dernière se retrouve en contact avec les éléments métalliques de construction (tels qu'armatures du béton) (NF C15-100 pour la France)

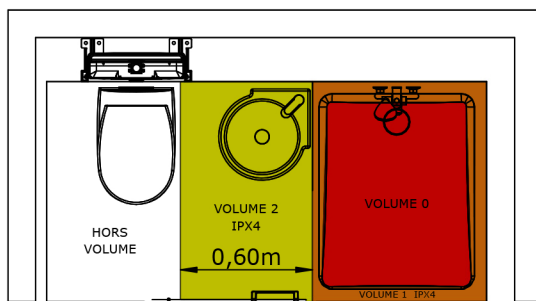
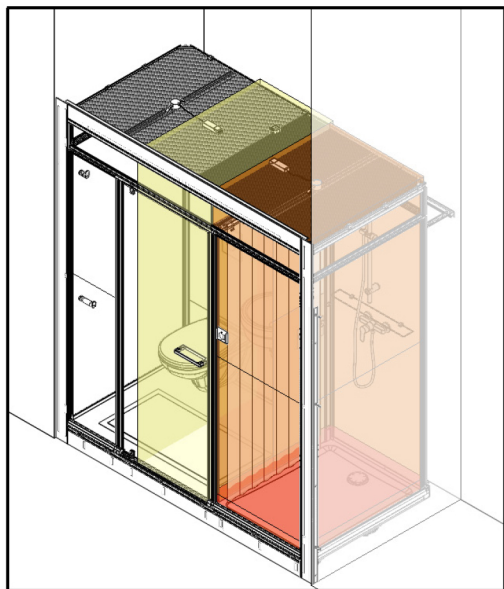

① Position de la cabine ② Position of the shower cubicle
 ③ Posición de la cabina de ducha ④ Posizione della cabina doccia
 ⑤ Positie van de douchecabine ⑥ Position der Duschkabine

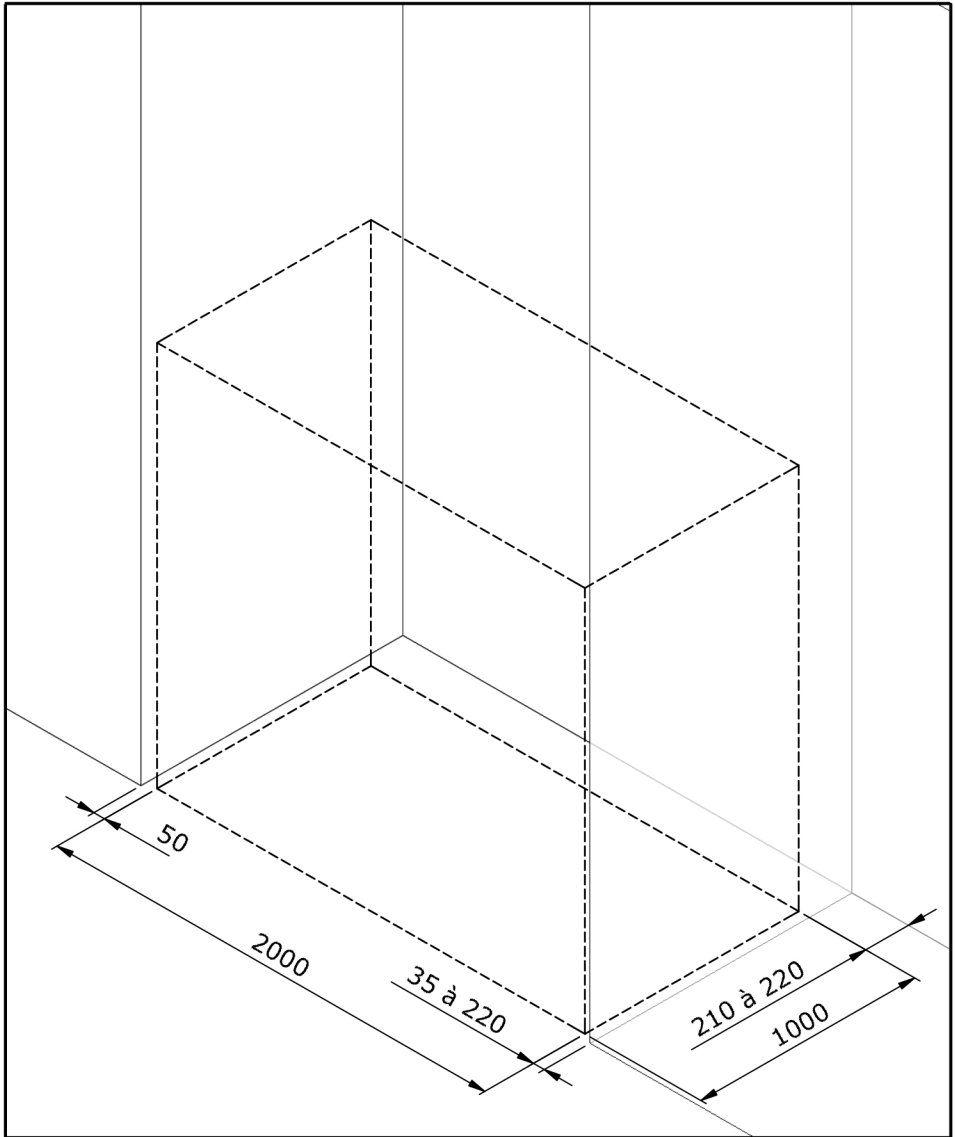

⑦ Cotes en mm ⑧ Dimensions in mm ⑨ Cotas en mm
 ⑩ Quote in mm ⑪ Afmetingen in mm ⑫ Maße sind in mm angegeben

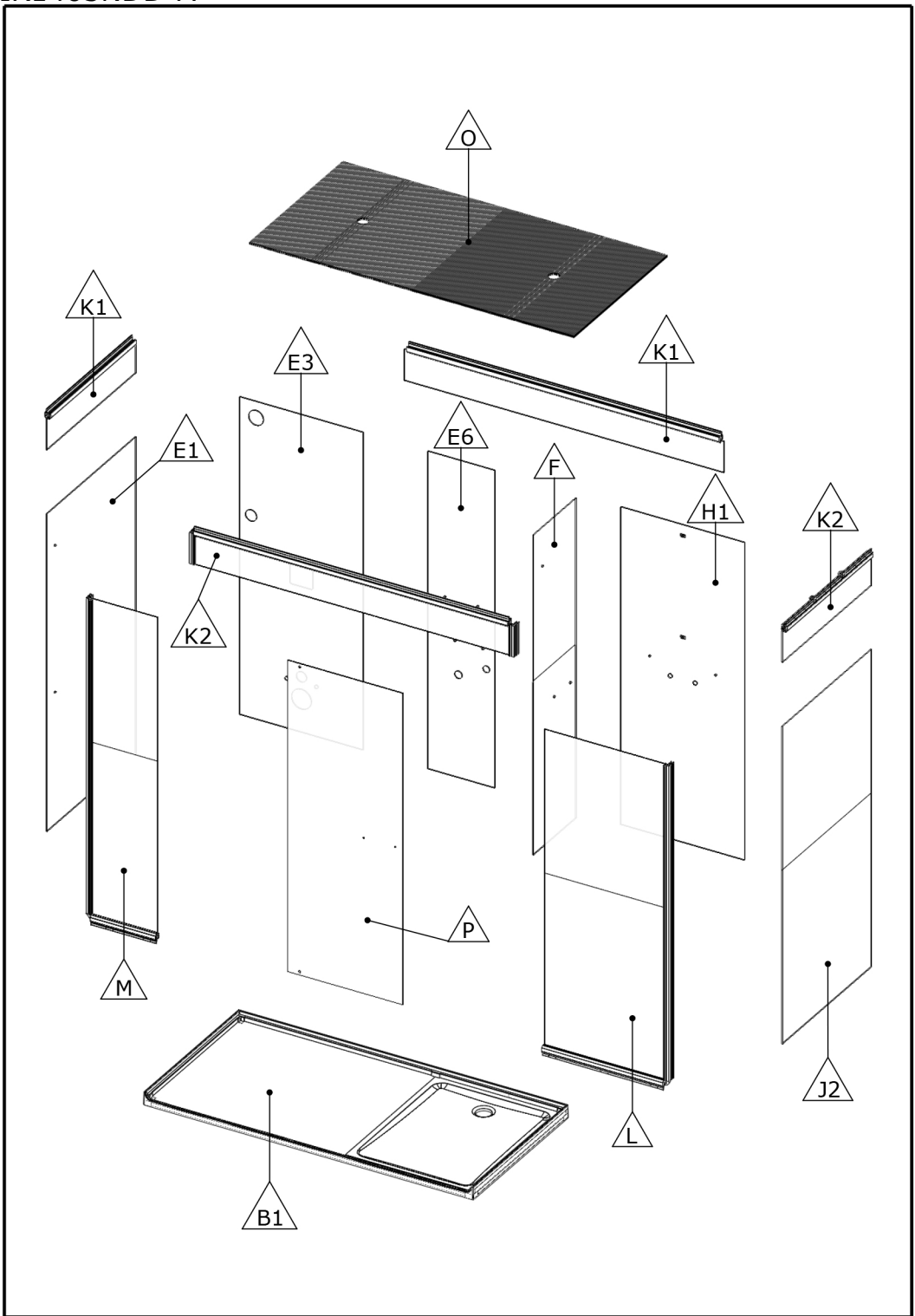

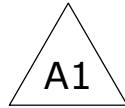

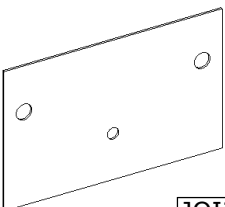
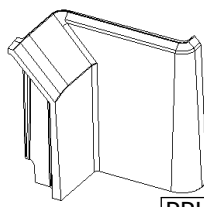
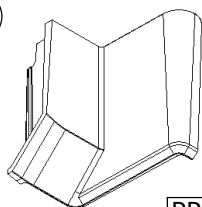
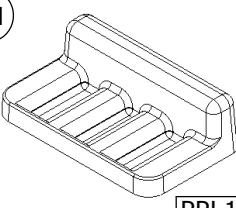
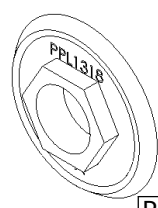
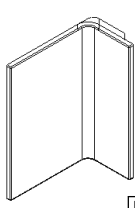
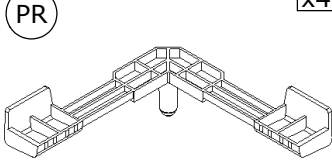
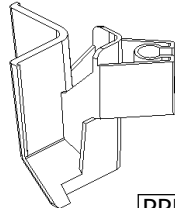
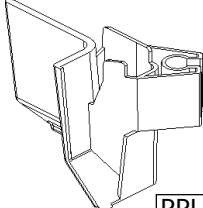
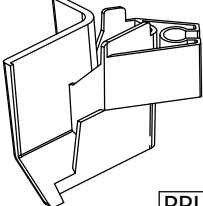
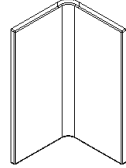
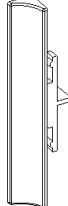
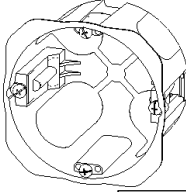
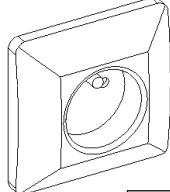
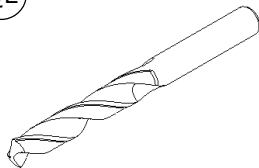
<p>(JC)  x2</p> <p>JOI335</p>	<p>(PE)  x1</p> <p>PPL1102</p>	<p>(PF)  x1</p> <p>PPL1103</p>
<p>(PM)  x1</p> <p>PPL1141</p>	<p>(PO)  x4</p> <p>PPL1318</p>	<p>(PQ)  x2</p> <p>PPL1417</p>
<p>(PR)  x4</p> <p>PPL1418</p>	<p>(PS)  x2</p> <p>PPL1419</p>	<p>(PT)  x1</p> <p>PPL1420</p>
<p>(PU)  x1</p> <p>PPL1421</p>	<p>(PV)  x2</p> <p>PPL1422</p>	<p>(PW)  x2</p> <p>PPL1424</p>
<p>(QC)  x1</p> <p>BOITIER08</p>	<p>(QJ)  x1</p> <p>FICHE102</p>	<p>(QL)  x1</p> <p>Ø3mm FORET01</p>

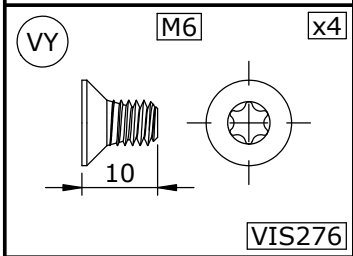
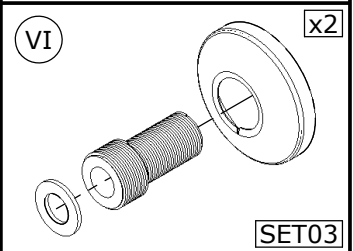
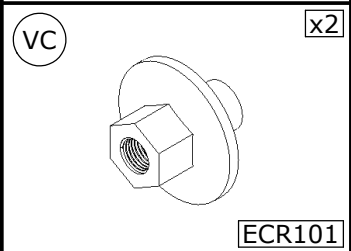
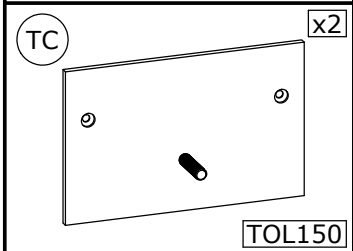
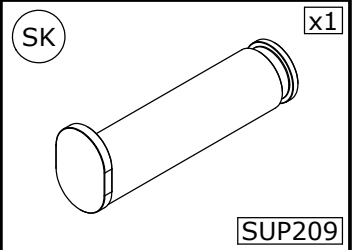
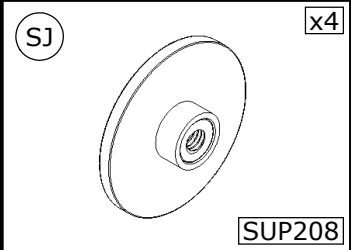
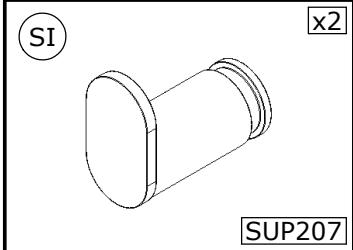
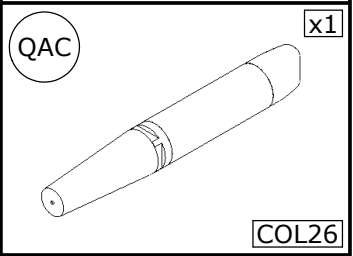
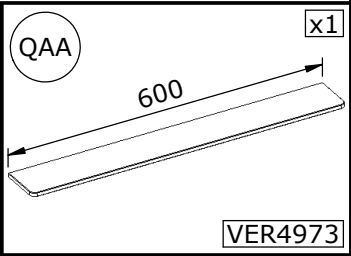
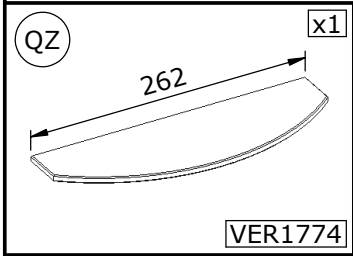
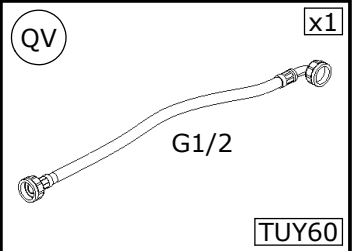
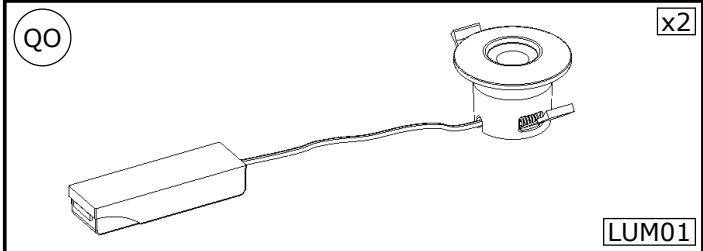
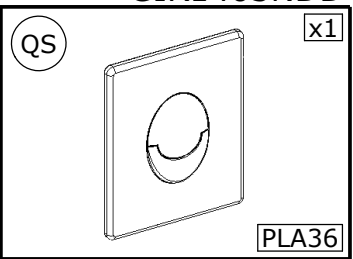
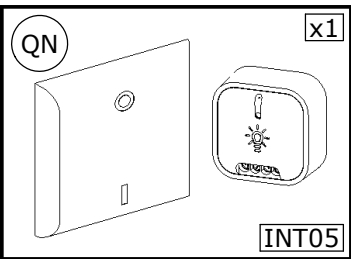
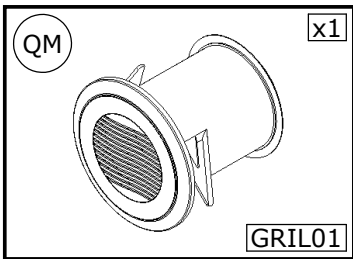

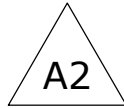

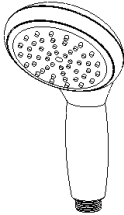
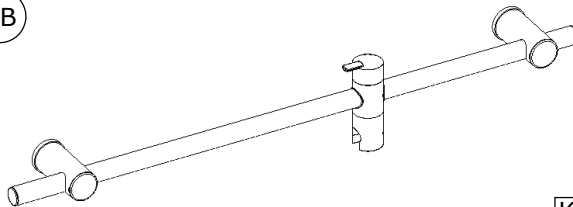
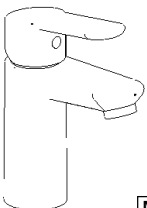
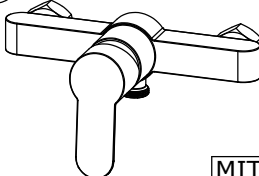
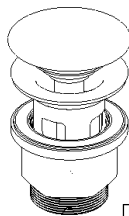
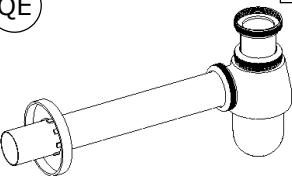
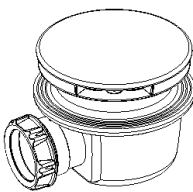
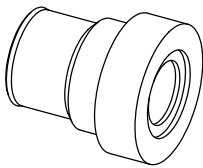
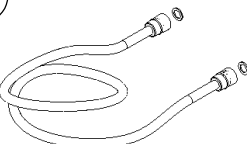
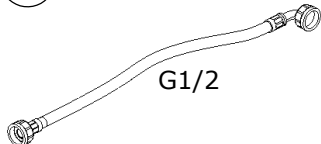
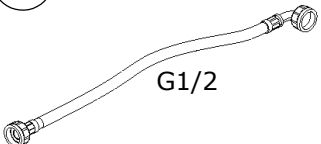
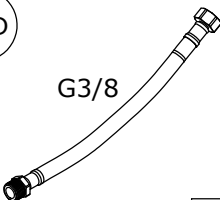

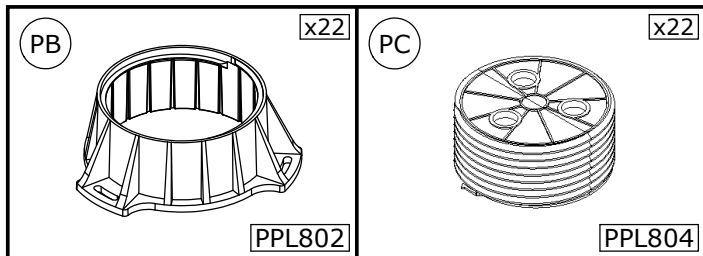
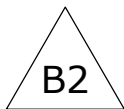
<p>KA</p>  <p>x1</p> <p>KIT173</p>	<p>KB</p>  <p>x1</p> <p>KIT178</p>	
<p>MA</p>  <p>x1</p> <p>MIT93</p>	<p>MB</p>  <p>x1</p> <p>MIT94</p>	<p>QD</p>  <p>x1</p> <p>BOND35</p>
<p>QE</p>  <p>x1</p> <p>BOND36</p>	<p>QF</p>  <p>x1</p> <p>BOND37</p>	<p>QH</p>  <p>x1</p> <p>MANCHON02</p>
<p>QK</p>  <p>x1</p> <p>FLEX05</p>	<p>QV</p>  <p>x1</p> <p>G1/2</p> <p>TUY60</p>	<p>QW</p>  <p>x1</p> <p>G1/2</p> <p>TUY61</p>
<p>QAD</p>  <p>x2</p> <p>G3/8</p> <p>TUY73</p>		

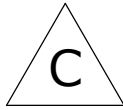

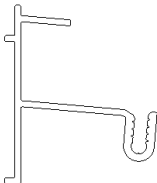
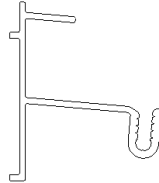
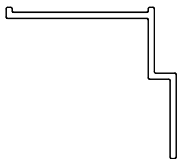
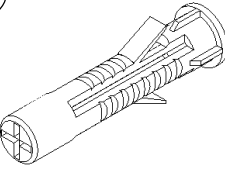
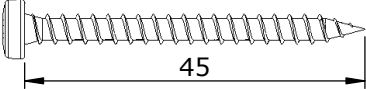
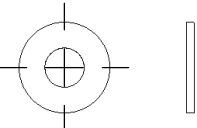

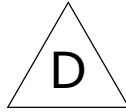
<p>(AJ)  x1</p> <p>Lg=1000mm 6209</p>	<p>(AJ)  x1</p> <p>Lg=2000mm 6209</p>	<p>(AK)  x2</p> <p>Lg=1940mm 6210</p>
<p>(VA)  x11</p> <p>CHE02</p>	<p>(VS)  x11</p> <p>VIS231</p>	
<p>(VG)  x11</p> <p>RON34</p>		

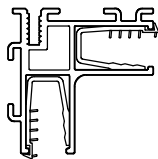
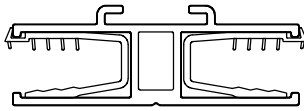

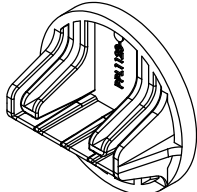
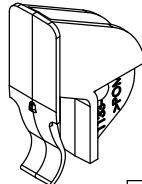
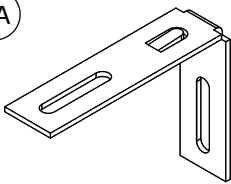
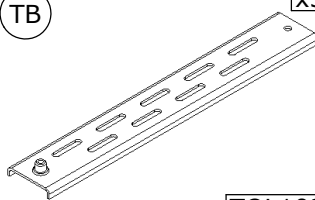
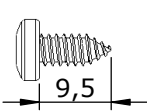
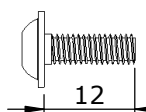
<p>(AC) x1</p>  <p>Lg=1926mm 6189</p>	<p>(AQ) x1</p>  <p>Lg=1907mm 6362</p>	<p>(JE) x10</p>  <p>Lg=2030mm PFL77</p>
<p>(PI) x1</p>  <p>PPL1128</p>	<p>(PL) x4</p>  <p>PPL1133</p>	<p>(TA) x4</p>  <p>TOL102</p>
<p>(TB) x3</p>  <p>TOL103</p>	<p>(VT) Ø4.2 x4</p>  <p>VIS238</p>	<p>(VU) M4 x4</p>  <p>VIS239</p>

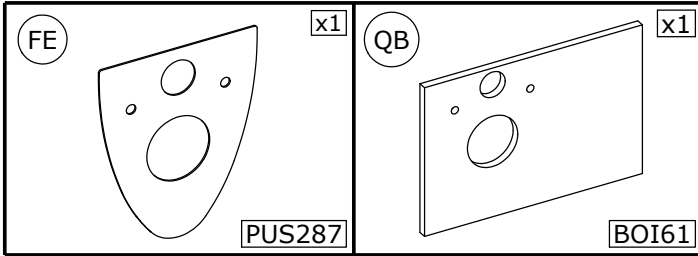

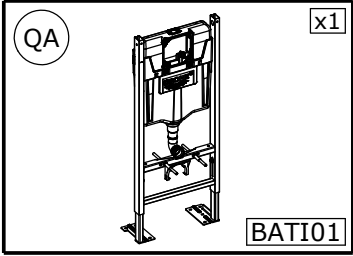

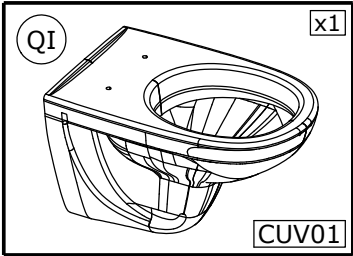
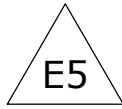

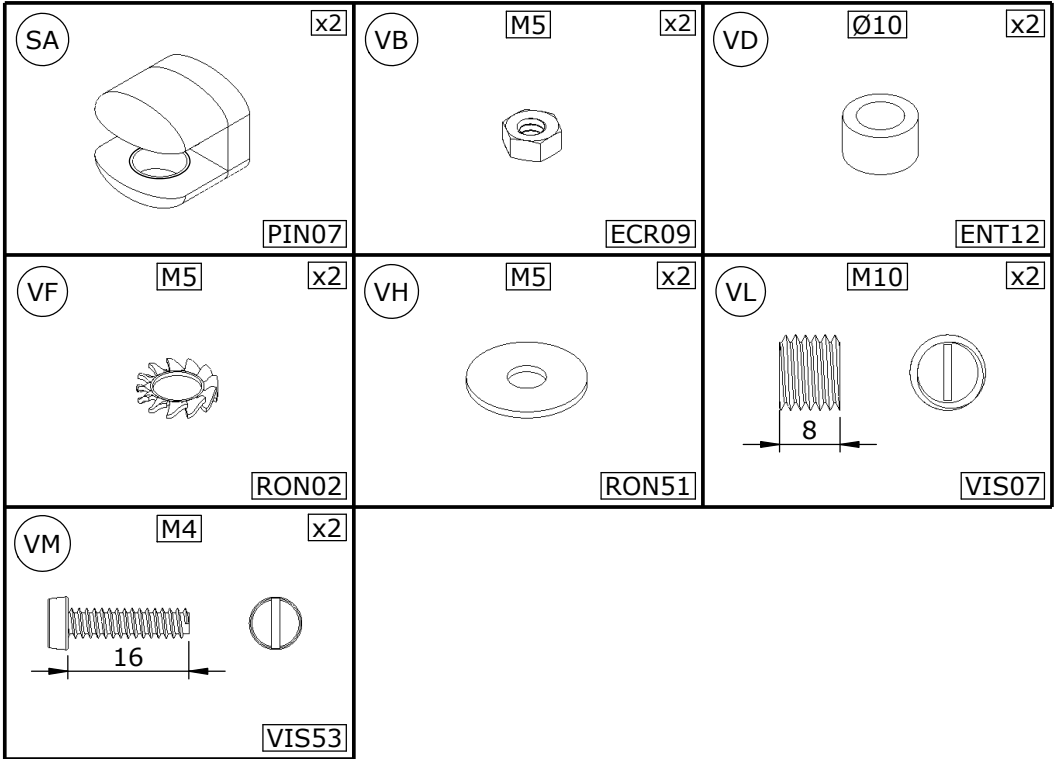
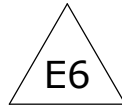



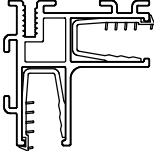
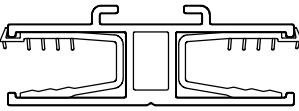

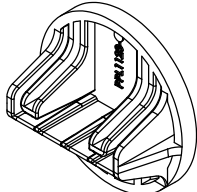
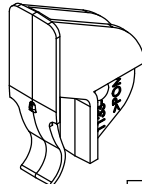
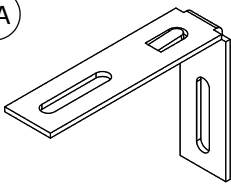
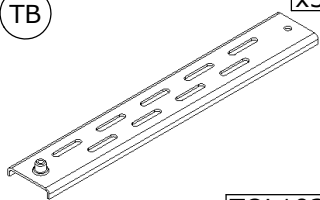
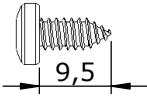
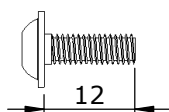

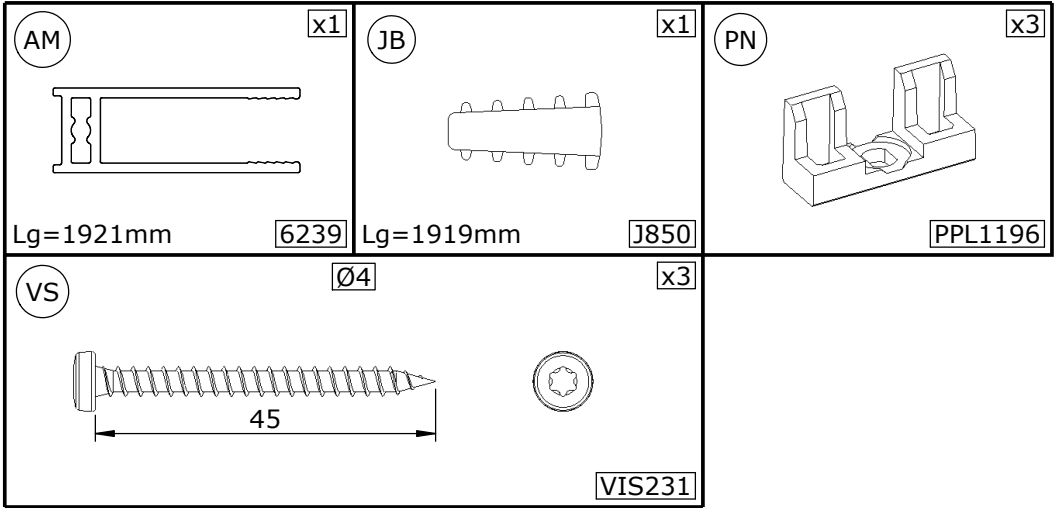
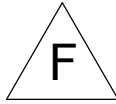

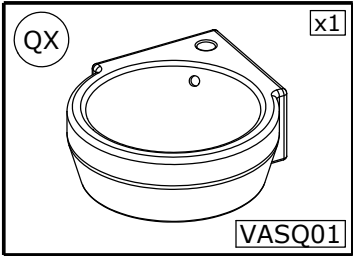
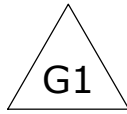
<p>(AC) x1</p>  <p>Lg=1926mm 6189</p>	<p>(AQ) x1</p>  <p>Lg=1907mm 6362</p>	<p>(JE) x10</p>  <p>Lg=2030mm PFL77</p>
<p>(PI) x1</p>  <p>PPL1128</p>	<p>(PL) x4</p>  <p>PPL1133</p>	<p>(TA) x4</p>  <p>TOL102</p>
<p>(TB) x3</p>  <p>TOL103</p>	<p>(VT) Ø4.2 x4</p>  <p>VIS238</p>	<p>(VU) M4 x4</p>  <p>VIS239</p>

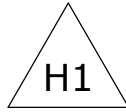

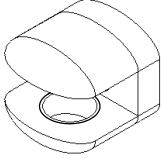

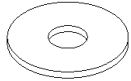
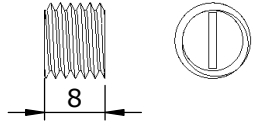
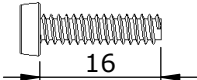
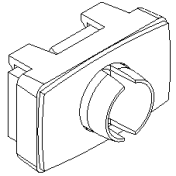

<p>SA x2</p>  <p style="text-align: right;">PIN07</p>	<p>VB x2</p> <p style="text-align: center;">M5</p>  <p style="text-align: right;">ECR09</p>	<p>VD x2</p> <p style="text-align: center;">Ø10</p>  <p style="text-align: right;">ENT12</p>
<p>VF x2</p> <p style="text-align: center;">M5</p>  <p style="text-align: right;">RON02</p>	<p>VH x2</p> <p style="text-align: center;">M5</p>  <p style="text-align: right;">RON51</p>	<p>VL x2</p> <p style="text-align: center;">M10</p>  <p style="text-align: right;">VIS07</p>
<p>VM x2</p> <p style="text-align: center;">M4</p>  <p style="text-align: right;">VIS53</p>	<p>VZ x2</p>  <p style="text-align: right;">SET202</p>	

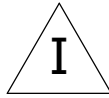

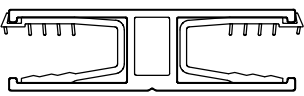
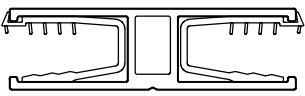
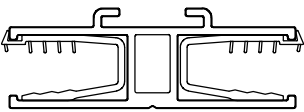
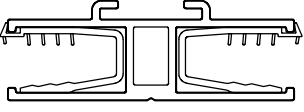
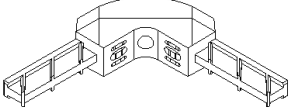
<p>AP x1</p>  <p>Lg=903mm 6361</p>	<p>AP x1</p>  <p>Lg=1908mm 6361</p>	<p>AQ x1</p>  <p>Lg=903mm 6362</p>
<p>AQ x1</p>  <p>Lg=1900mm 6362</p>	<p>PP x4</p>  <p style="text-align: right;">PPL1416</p>	

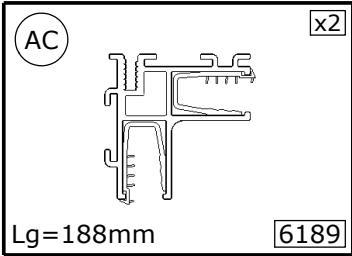
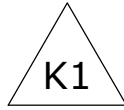

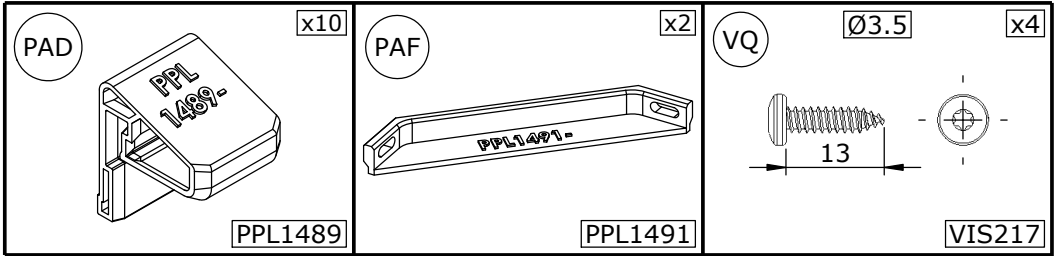
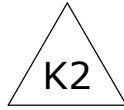

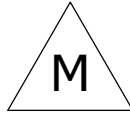



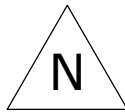

<p>(AD) x1</p> <p>Lg=765mm 6194</p>	<p>(AI) x2</p> <p>Lg=300mm 6206</p>	<p>(PD) x4</p> <p style="text-align: right;">PPL1099</p>
<p>(PG) x1</p> <p style="text-align: right;">PPL1126</p>	<p>(PH) x1</p> <p style="text-align: right;">PPL1127</p>	<p>(SE) x1</p> <p style="text-align: right;">SET185</p>
<p>(SH) x1</p> <p style="text-align: right;">SUP203</p>	<p>(VO) Ø3.5 x1</p> <p style="text-align: right;">VIS214</p>	<p>(VQ) Ø3.5 x2</p> <p style="text-align: right;">VIS217</p>
<p>(VW) Ø3.5 x4</p> <p style="text-align: right;">VIS253</p>		

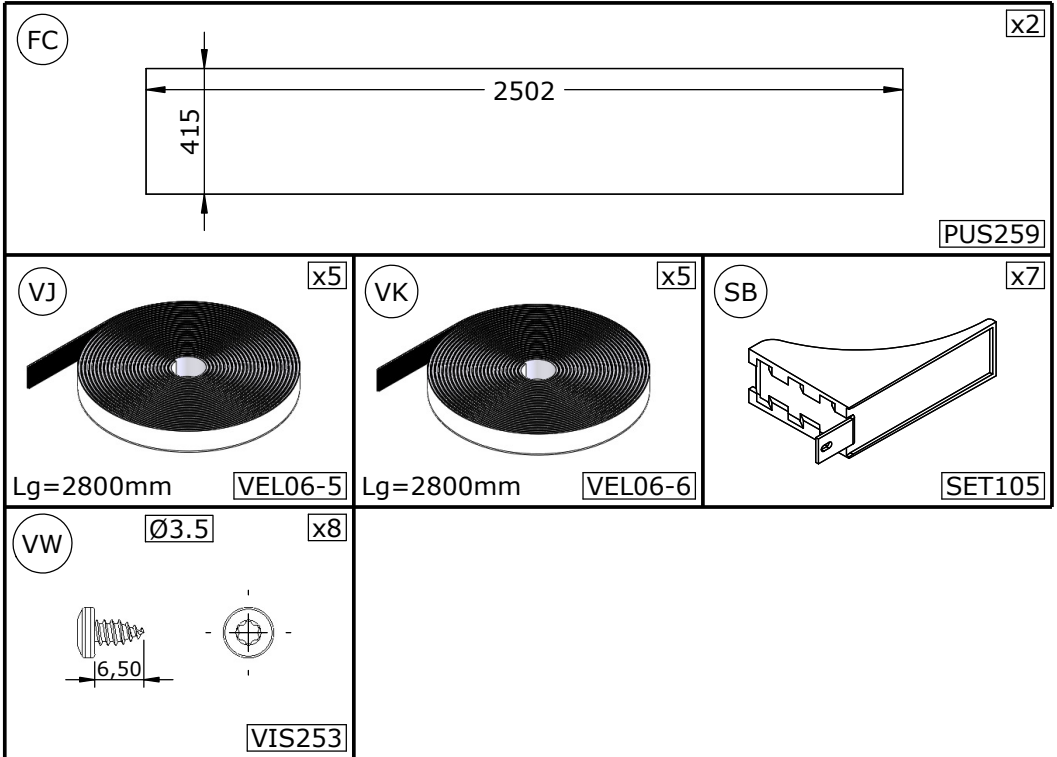
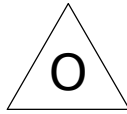

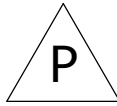
<p>(AL) x1</p> <p>Lg=937mm 6233</p>	<p>(AP) x1</p> <p>Lg=1891mm 6361</p>	<p>(AP) x1</p> <p>Lg=1891mm 6361</p>
<p>(AS) x1</p> <p>Lg=1937mm 6364</p>	<p>(PA) x3</p> <p>CAP04</p>	<p>(PX) x1</p> <p>PPL1425</p>
<p>(PY) x1</p> <p>PPL1426</p>	<p>(VP) Ø3.5 x2</p> <p style="text-align: center;">19</p> <p>VIS215</p>	<p>(VQ) Ø3.5 x4</p> <p style="text-align: center;">13</p> <p>VIS217</p>
<p>(VX) Ø3.5 x1</p> <p style="text-align: center;">32</p> <p>VIS255</p>		

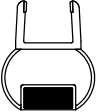
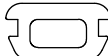

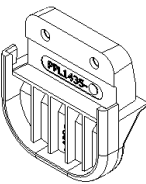
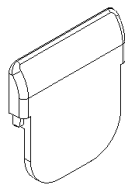
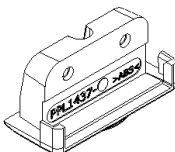
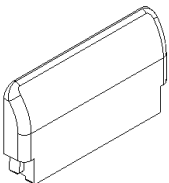
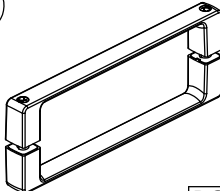
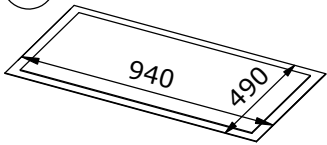

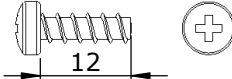
<p>(JA) x1</p>  <p>Lg=1884mm AI185</p>	<p>(JF) x1</p>  <p>Lg=2000mm PFL87</p>	<p>(JH) x1</p>  <p>Lg=1877mm J828</p>
<p>(PZ) x1</p>  <p>PPL1435</p>	<p>(PAA) x1</p>  <p>PPL1436</p>	<p>(PAB) x1</p>  <p>PPL1437</p>
<p>(PAC) x1</p>  <p>PPL1438</p>	<p>(QR) x1</p>  <p>PGN49</p>	<p>(QT) x1</p>  <p>TAPIS02</p>
<p>(VE) M4 x4</p>  <p>RON01</p>	<p>(VN) Ø4 x4</p>  <p>VIS124</p>	

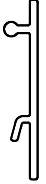
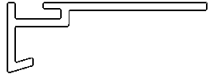
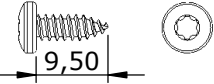

<p>AB</p>  <p>Lg=1975mm</p> <p>5526</p>	<p>AE</p>  <p>Lg=1920mm</p> <p>6195</p>	<p>AF</p>  <p>Lg=2500mm</p> <p>6197</p>
<p>VT</p> <p>Ø3.5</p>  <p>9,50</p> <p>VIS237</p>		

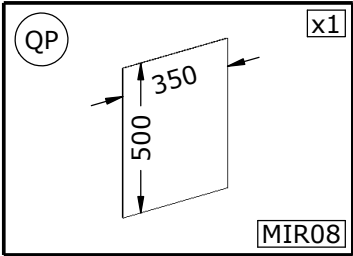
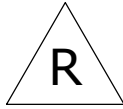

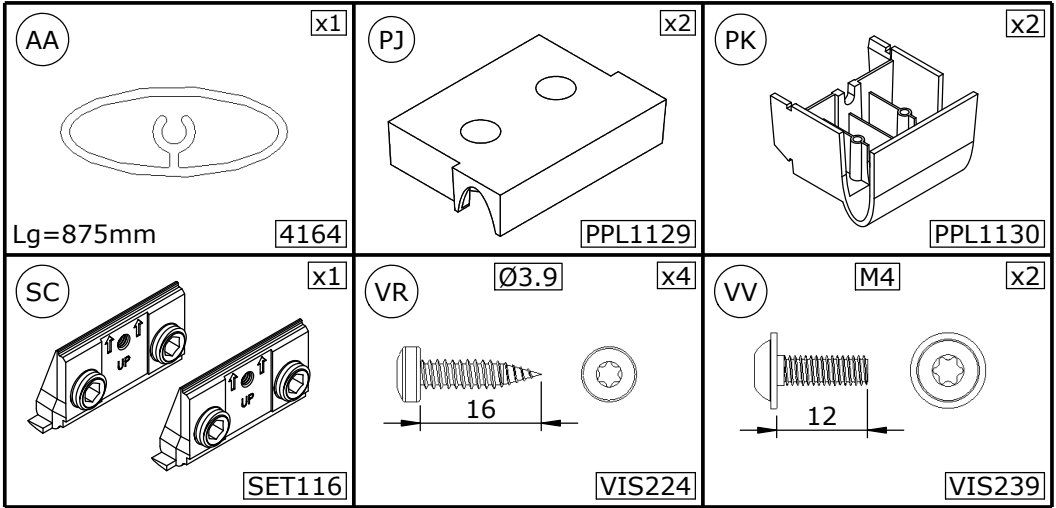
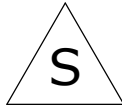

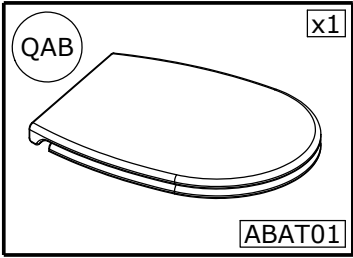
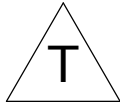

●Outils nécessaires ●Tools required ●Equipamiento necesario
●Attrezzatura necessaria ●Benodigde gereedschap ●Werkzeuge erforderlich

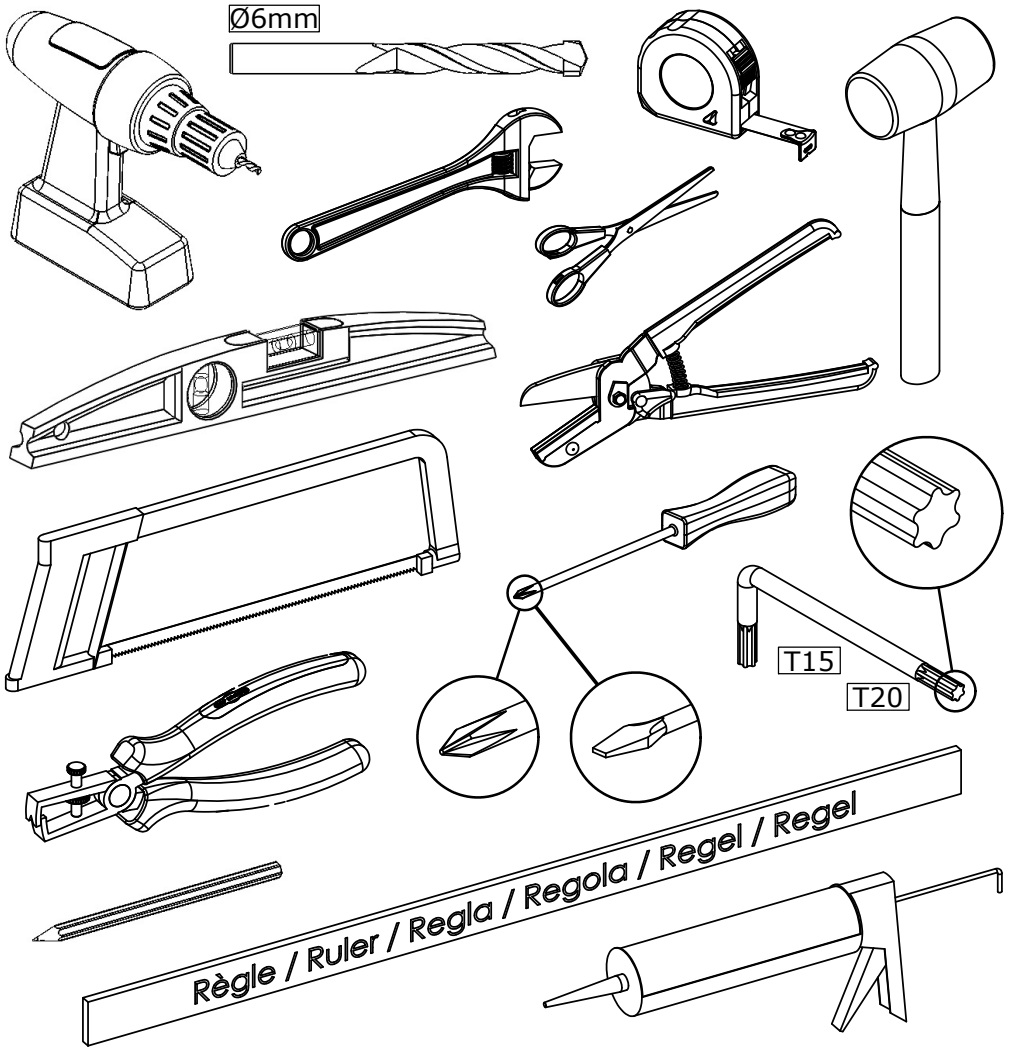

- Utiliser un silicone adapté au matériau de chaque support (faïence, acrylique, etc.)
- Use a silicone sealant that is intended for the surrounding materials (ceramic, acrylic, etc.)
- Usar una silicona adecuada para cada tipo de material (loza, acrílico, etc.)
- Utilizzare un silicone adatto a qualsiasi materiale (ceramica, acrilico, ecc.)
- Gebruik siliconenkit die geschikt is voor iedere ondergrond (tegelwerk, acryl, etc.)
- Für das jeweilige Trägermaterial (Stein, Acryl usw.) geeignetes Silikon verwenden.



- Zone de décaissement pour un montage de receveur sans pieds
- Ⓞ Area required for the installation of the tray without feet
- Zona rebajada para la instalación del plato sin pies
- Zone necessarie per un montaggio del piatto senza piedi
- Afloopgebied voor de montage van een douchebak zonder poten
- Freier Raum für Montage der Duschwanne ohne FüÙe

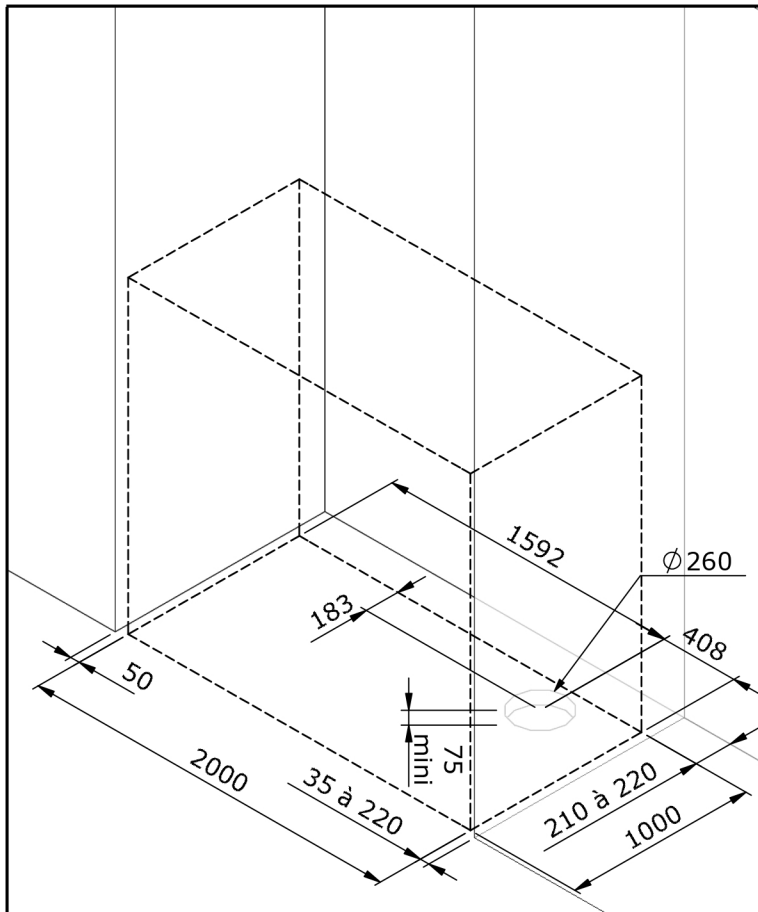

- Cotes en mm Ⓞ Dimensions in mm ● Cotas en mm
- Quote in mm ● Afmetingen in mm ● Maße sind in mm angegeben

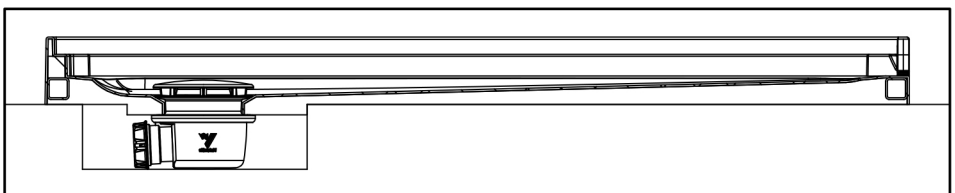



SERVICE APRÈS-VENTE AFTER-SALES SERVICE

FRANCE

+33 (0)2 40 21 29 45

UK

+44 (0)20 8842 0033

IRELAND

+353 04697 33102

DEUTSCHLAND

+49 (0) 6074 / 30928 0

ITALIA

+39 02 30559420

ÖSTEREICH

+43 1 710 60 70

SUISSE/SCHWEIZ

+41 (0)32 631 04 74

ESPAÑA

+34 93 544 60 76

NEDERLAND

+31 475 487 100

BELGIQUE/BELGIË

+31 475 487 100

РОССИЯ

+7 495 258-29-51

PORTUGAL

+351 219 112 785