

- F Notice de montage
- GB Installation instructions
- E Manual de instalación
- I Istruzioni di montaggio
- NL Montage-instructies
- D Montageanleitung

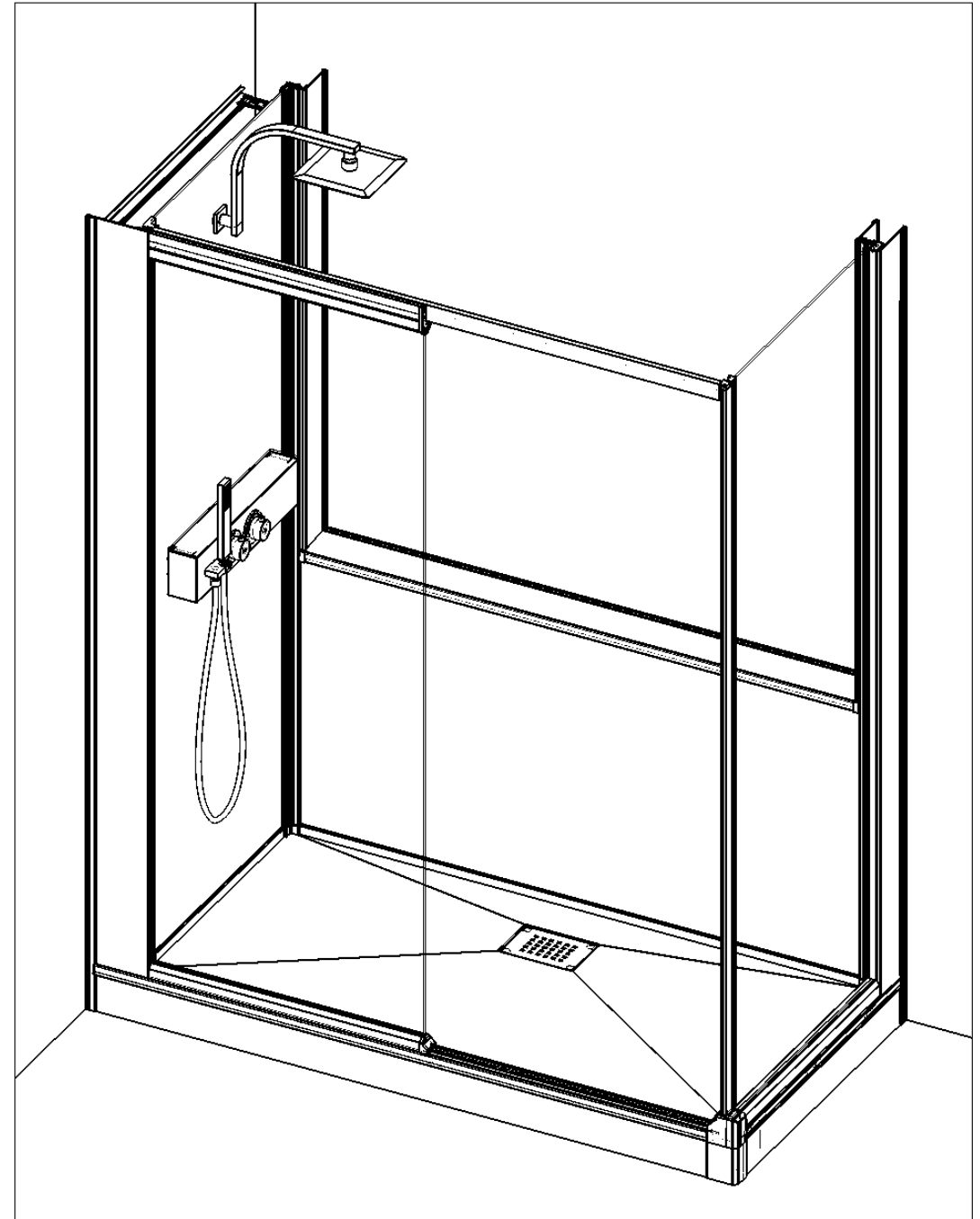

- Attention aux étapes :
- Check installation steps :
- Atención a los pasos :
- Attenzione ai passi :
- Aandacht voor de stappen :
- Achtung vor den Schritten :

P. 2

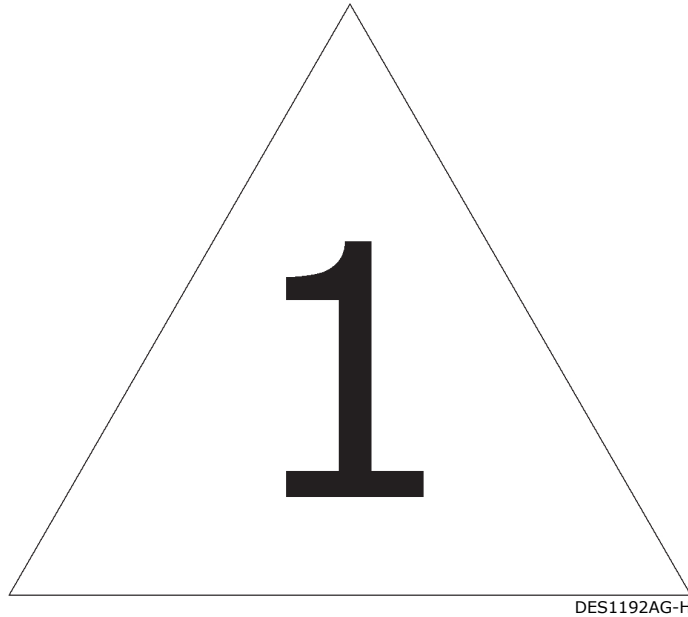

● **NOUVEAUTÉ** : Le joint d'étanchéité est désormais pré-positionné en usine. Collez-le sur toute sa longueur avant montage.

● **NEW** : The seal is now pre-positioned at the factory. Paste it along its entire length before mounting.

● **NUEVO** : El sello ahora está preposicionada en la fábrica. Pégallo en toda su longitud antes del montaje.

● **NUOVO** : Il sigillo è ora pre-posizionato in fabbrica. Incollalo per tutta la sua lunghezza prima di montarlo.

● **NIEUW** : De afdichting is nu vooraf ge-positioneerd in de fabriek. Plak het over de gehele lengte voordat u het monteert.

● **NEU** : Die Dichtung ist jetzt werkseitig vorpositioniert. Fügen Sie es vor der Montage über die gesamte Länge ein.

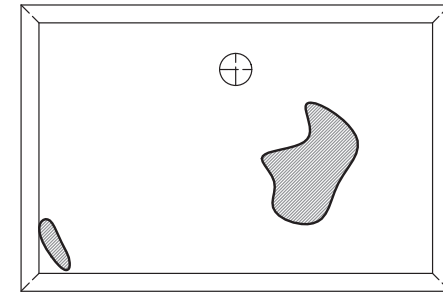

● D'éventuelles irrégularités de surface sur le dessous de votre receveur n'empêchent pas une installation conforme aux préconisations de pose. La colle (polyuréthane ou MS polymère) comblera facilement ces manques lors du collage.

● Any surface irregularities on the underside of the shower tray have no influence on the installation according to the installation recommendations. The adhesive (polyurethane or MS polymer) compensates for these unevenness when bonding the feet off without any problems.

● Posibles irregularidades de la superficie en la parte inferior del receptor no impida la instalación de acuerdo con las recomendaciones de instalación. El adhesivo (poliuretano o polímero MS) rellenará fácilmente estos huecos al pegar los pies.

● Eventuali irregolarità della superficie nella parte sotto della doccia non impediscono l'installazione in base alle raccomandazioni di montaggio. La colla (poliuretano o MS polimero) riempirà facilmente queste lacuna quando si incollano i piedini.

● Eventuele onregelmatigheden in de vlakke onderzijde van uw douchebak vormen geen belemmering voor een installatie conform aan de gestelde richtlijnen. De lijm (polyurethaan of MS-polymeer) vult eventuele openingen makkelijk op tijdens het lijmen.

● Eventuelle Unregelmäßigkeiten der Oberfläche an der Unterseite Ihrer Duschwanne haben keinen Einfluss auf die Installation gemäß den Einbauempfehlungen. Der Klebstoff (Polyurethan oder MS-Polymer) gleicht diese Unebenheiten beim Verkleben problemlos aus.



● Aspirer le dessous de votre receveur avant la pose

● Vacuum the bottom of the shower tray before installation

● Aspirar la parte inferior de su plato de ducha antes de instalarlo

● Aspirare la parte sottostante del piatto doccia prima dell'installazione

● Stofzuig de bodem van de douchebak voor de installatie

● Saugen Sie den Boden der Duschwanne vor der Installation ab



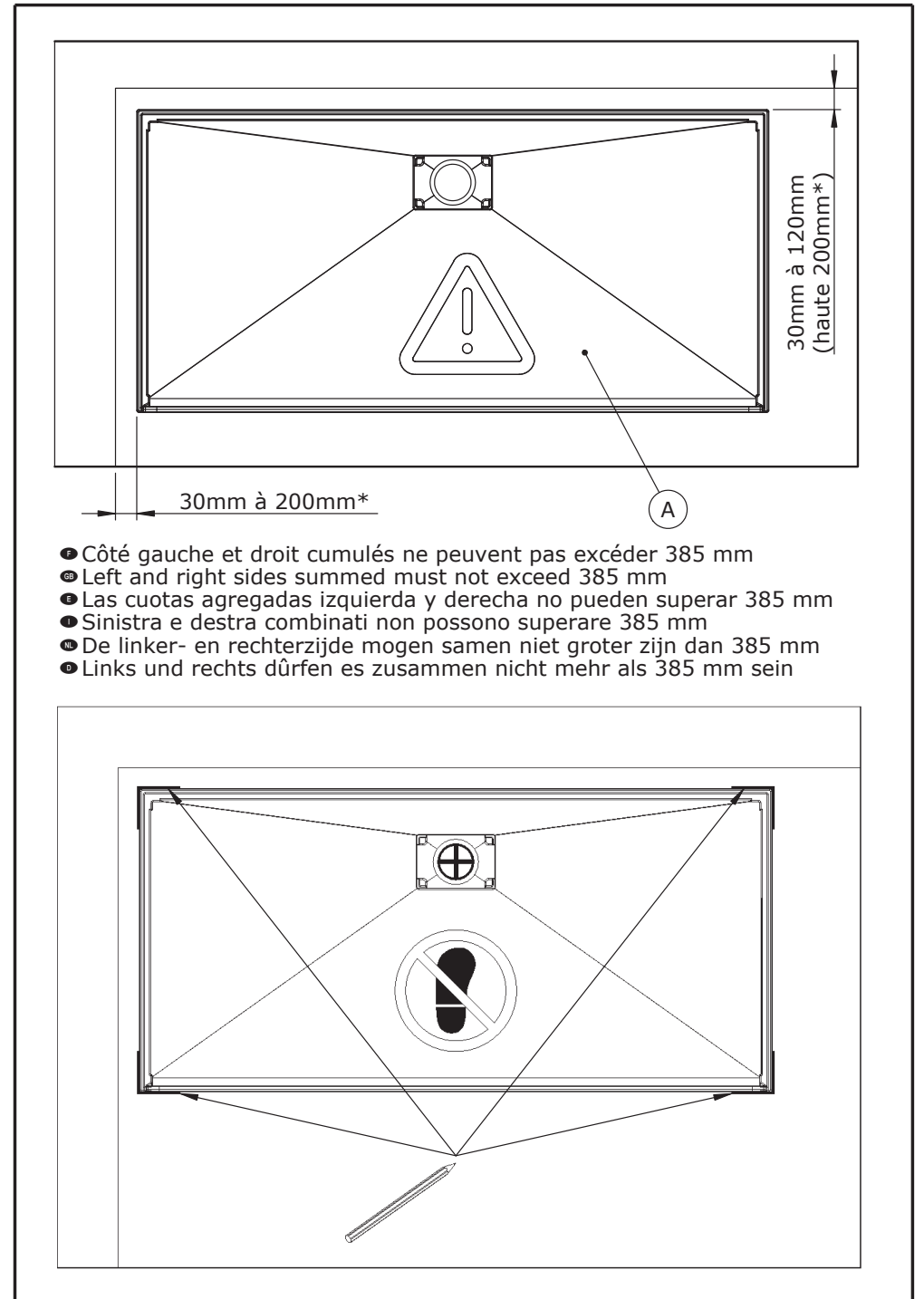
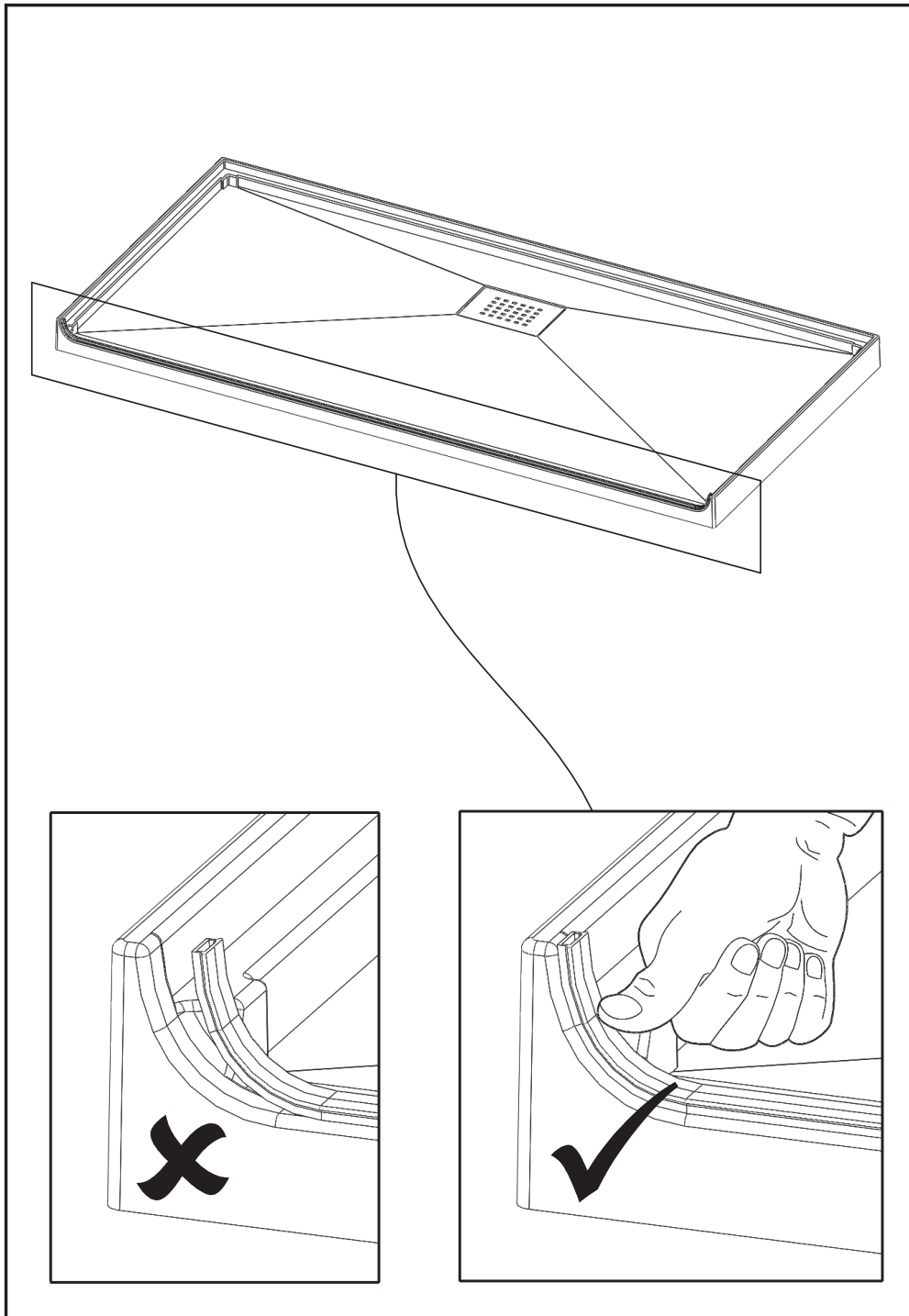

100

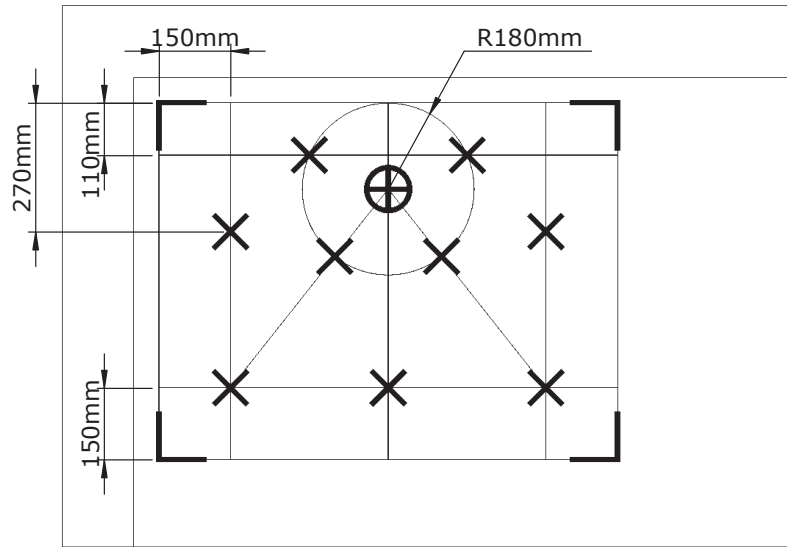

120 / 140 / 160 / 170

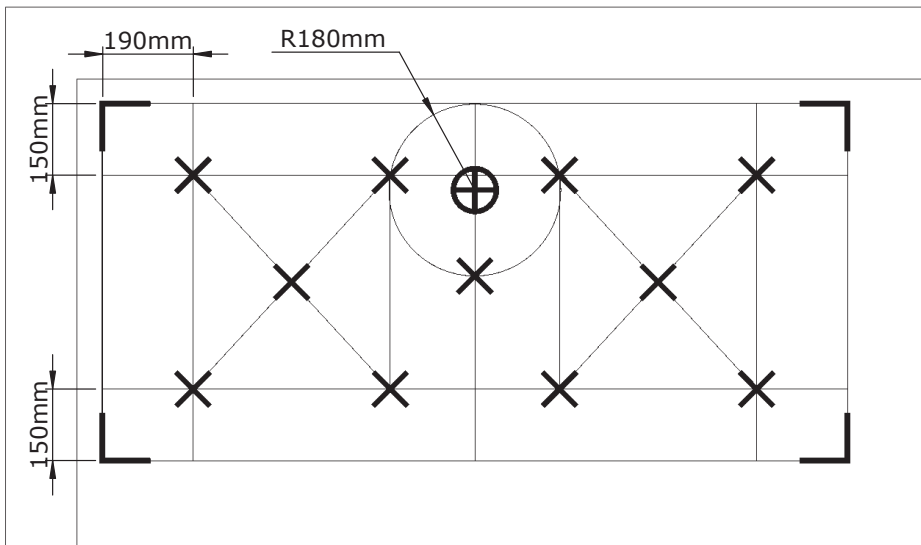

- Pose de receveur avec pieds ● Laying the tray with adjustable feet
- Instalación del plato con pies ● Posa del piatto con piedi
- Montage van douchebak op poten ● Installation der duschwanne mit Füßen

- Colle polyuréthane
- Polyurethane adhesive
- Pegamento de poliuretano
- Adesivo poliuretánico
- Polyurethaan kit
- Polyurethan-klebstoff

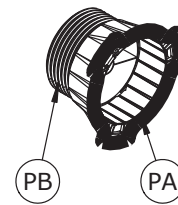
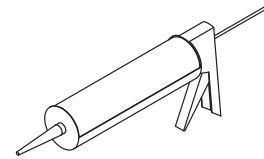

60mm à 110mm

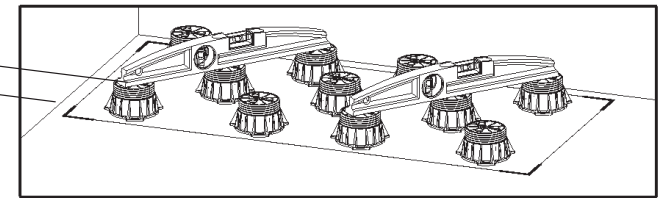
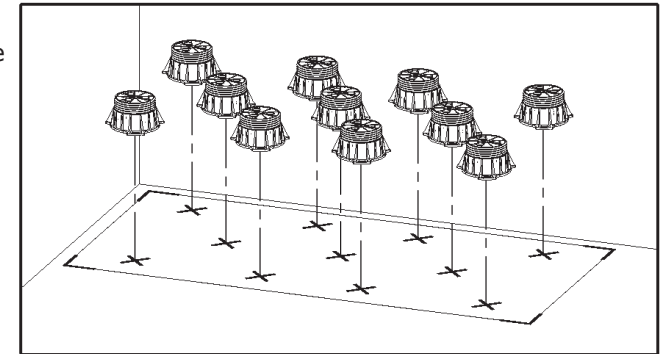

- Pose de receveur sans pieds ● Laying the tray without feet
- Instalación del plato sin pies ● Posa del piatto senza piedi
- Montage van douchebak zonder poten ● Installation der duschwanne ohne Füßen

- Colle polyuréthane
- Polyurethane adhesive
- Pegamento de poliuretano
- Adesivo poliuretánico
- Polyurethaan kit
- Polyurethan-klebstoff

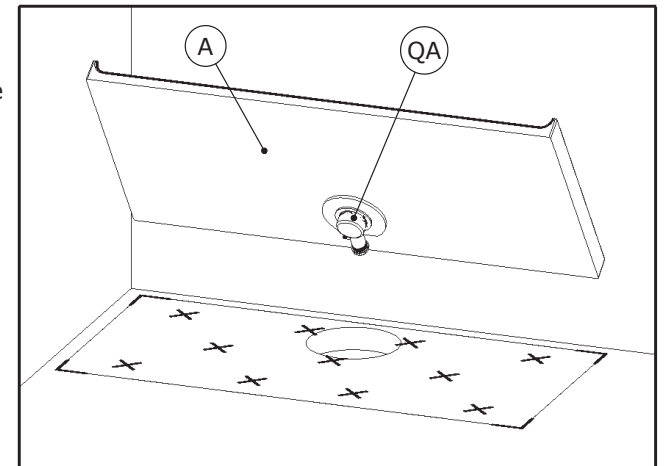
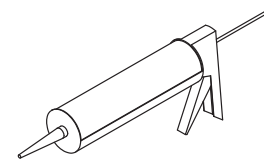



- Vérifier que tous les pieds soient bien en contact avec le receveur
- Check that all feet are in contact with the shower tray
- Compruebe que todos los pies están en contacto con el plato de ducha
- Controllare che tutti i piedi sono in contatto con il piatto doccia
- Controleer of alle voeten in contact staan met de douchebak
- Prüfen, ob alle Füße sind in Kontakt mit der Duschwanne

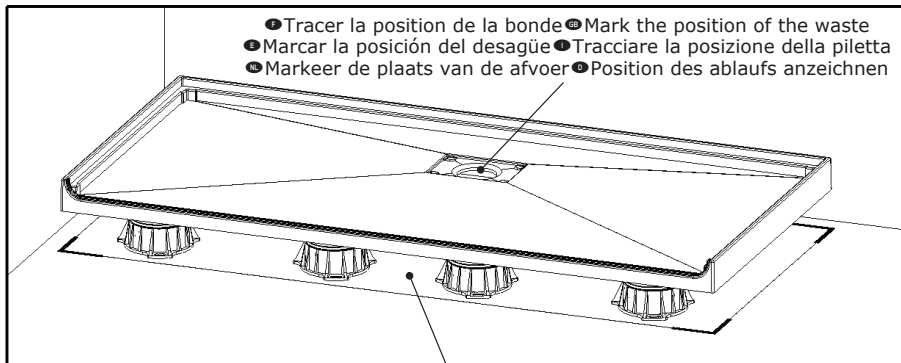

- Tracer la position de la bonde
- Mark the position of the waste
- Marcar la posición del desagüe
- Tracciare la posizione della piletta
- Markeer de plaats van de afvoer
- Position des ablaufs anzeichnen

- Sol rigide et non-humide indispensable
- Ensure a solid dry surface
- Suelo rígido y sin humedad imprescindible
- Il suolo deve essere ben asciutto e non umido
- De ondergrond moet volkomen vlak en droog zijn
- Untergrund muss fest und darf nicht feucht sein

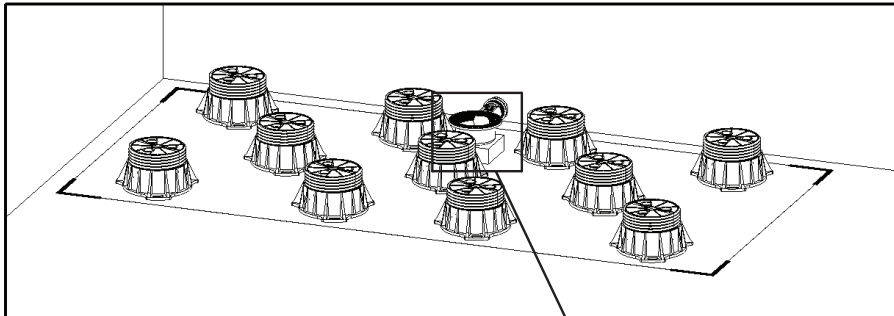

- Raccorder votre évacuation à la bonde
- Connect the waste pipe
- Conectar el tubo de evacuación al sumidero
- Collegare il tubo di evacuazione alla piletta
- Sluit de afvoer aan op het afvoerputje
- Das abflussrohr an den ablauf anschließen

QA

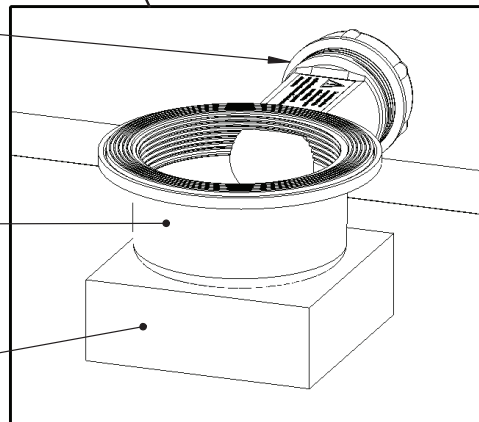

- Cale en bois si nécessaire
- Provide support if necessary
- Soporte de madera en caso necesario
- Supporto in legno, se necessario
- Gebruik eventueel een houten blokje
- Ggf. holzklötzchen vorsehen

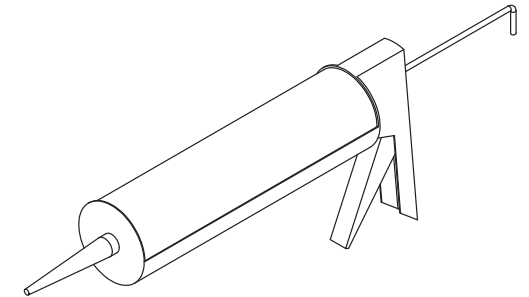

- Colle polyuréthane
- Polyurethane adhesive
- Pegamento de poliuretano
- Adesivo poliuretano
- Polyurethaan kit
- Polyurethan-klebstoff

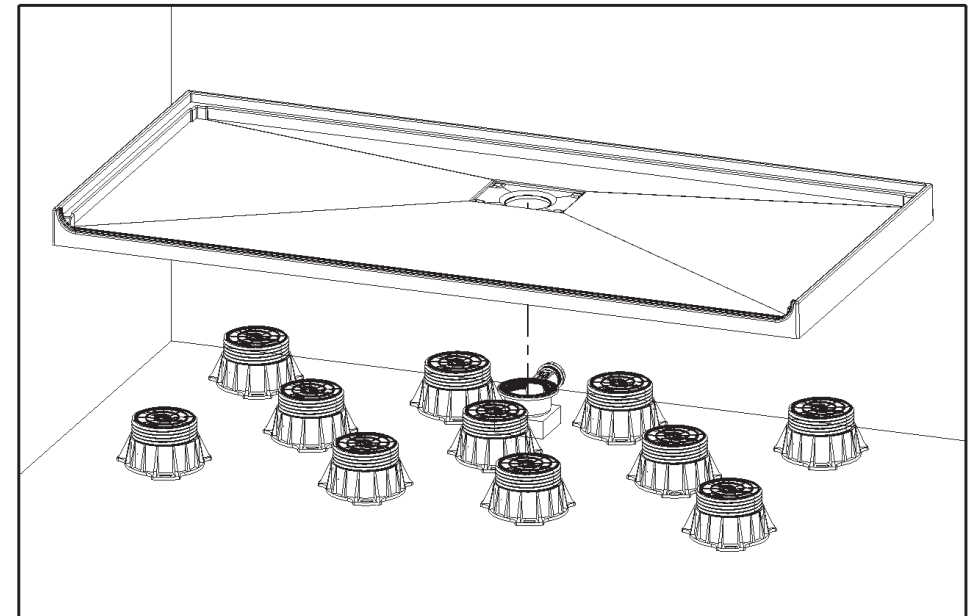
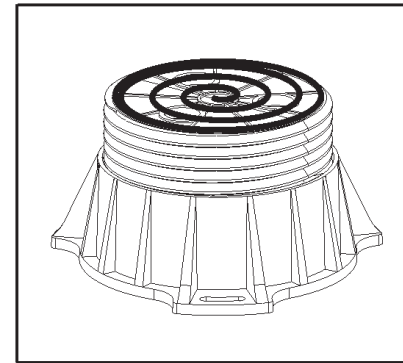

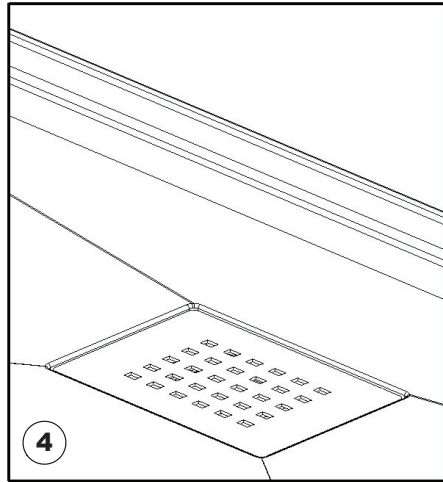
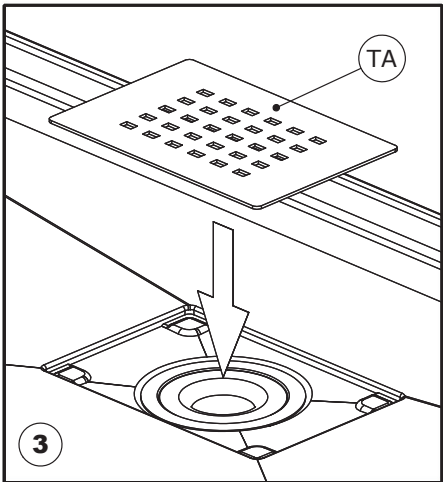
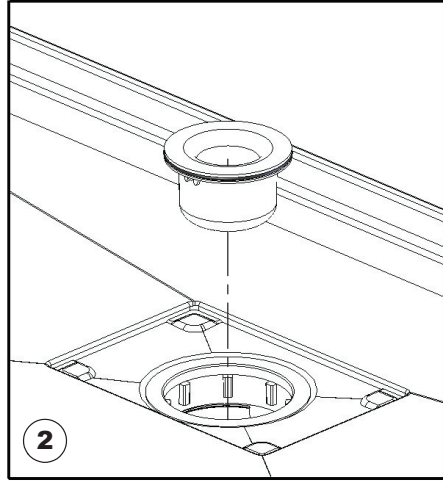
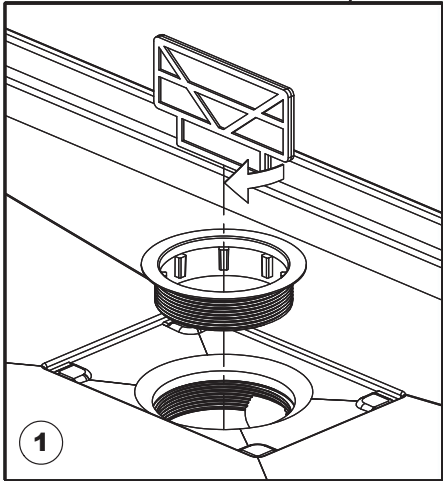
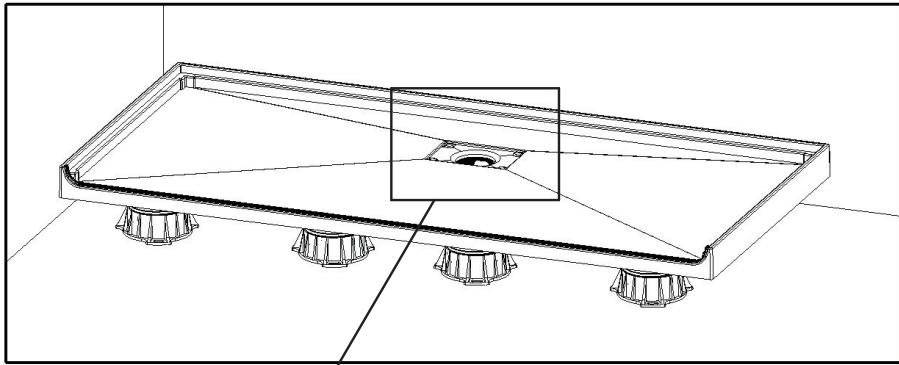

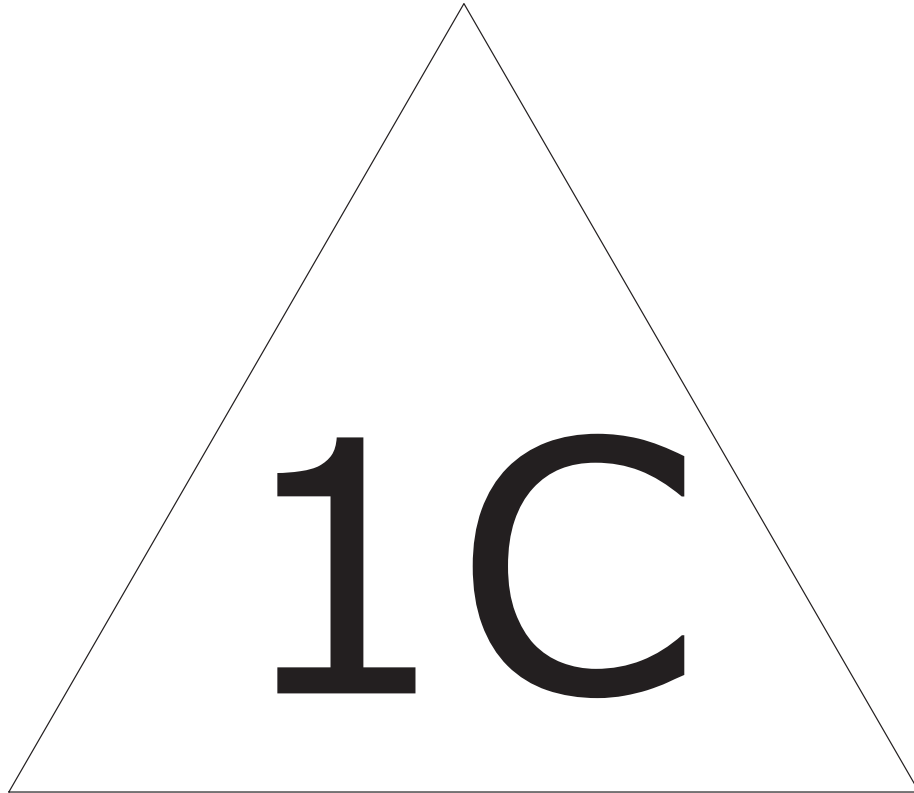

DES1229AG-B

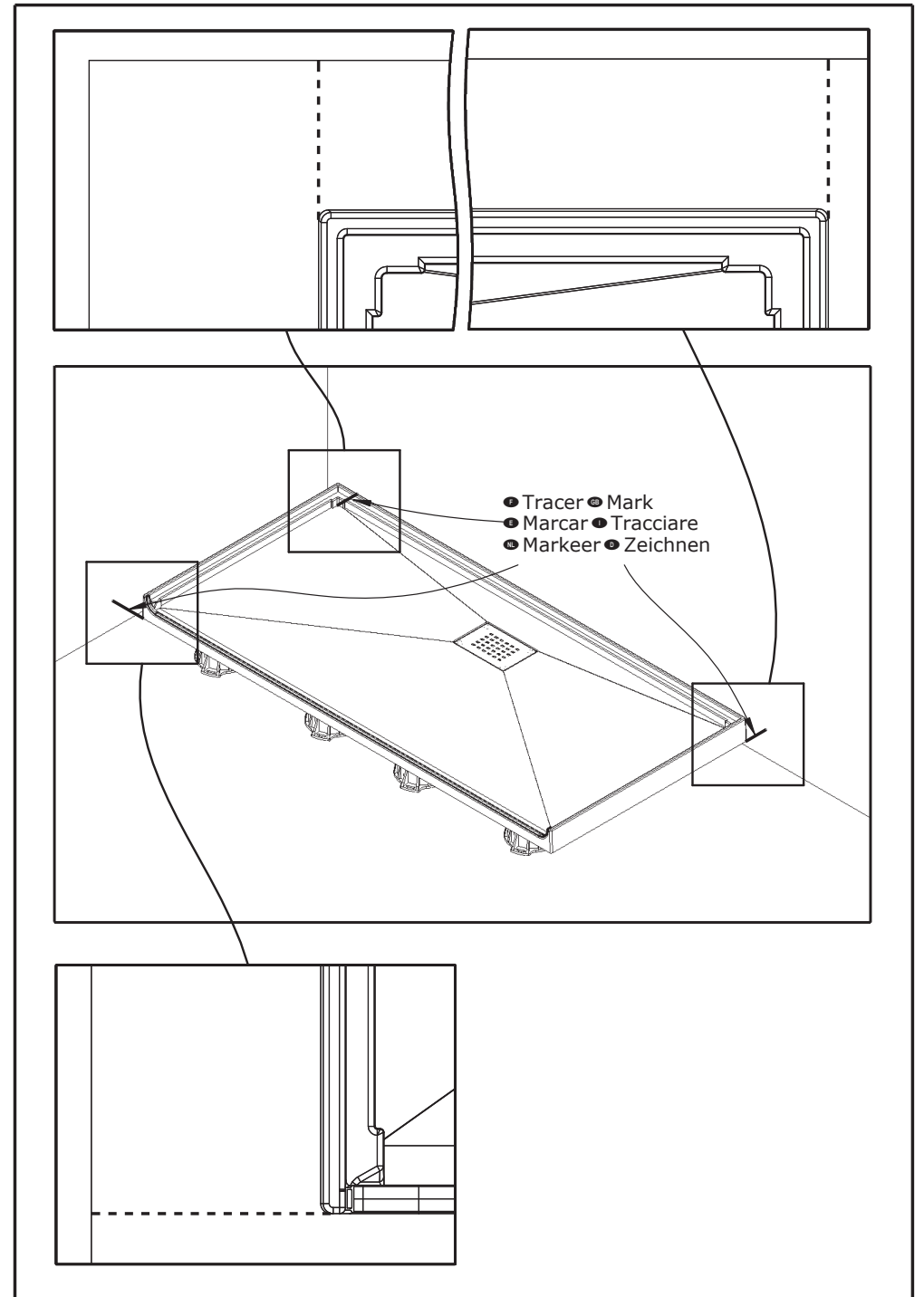

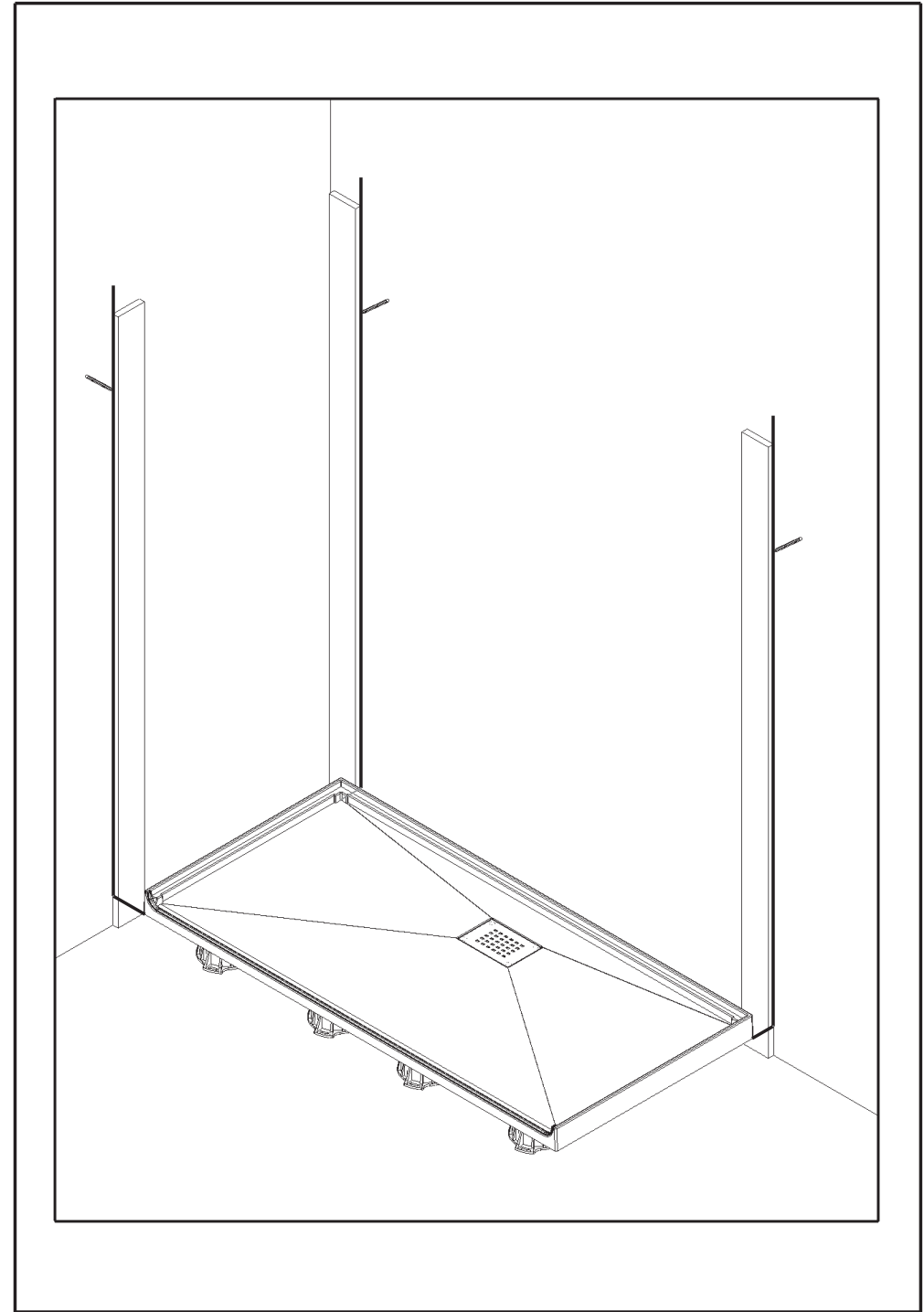
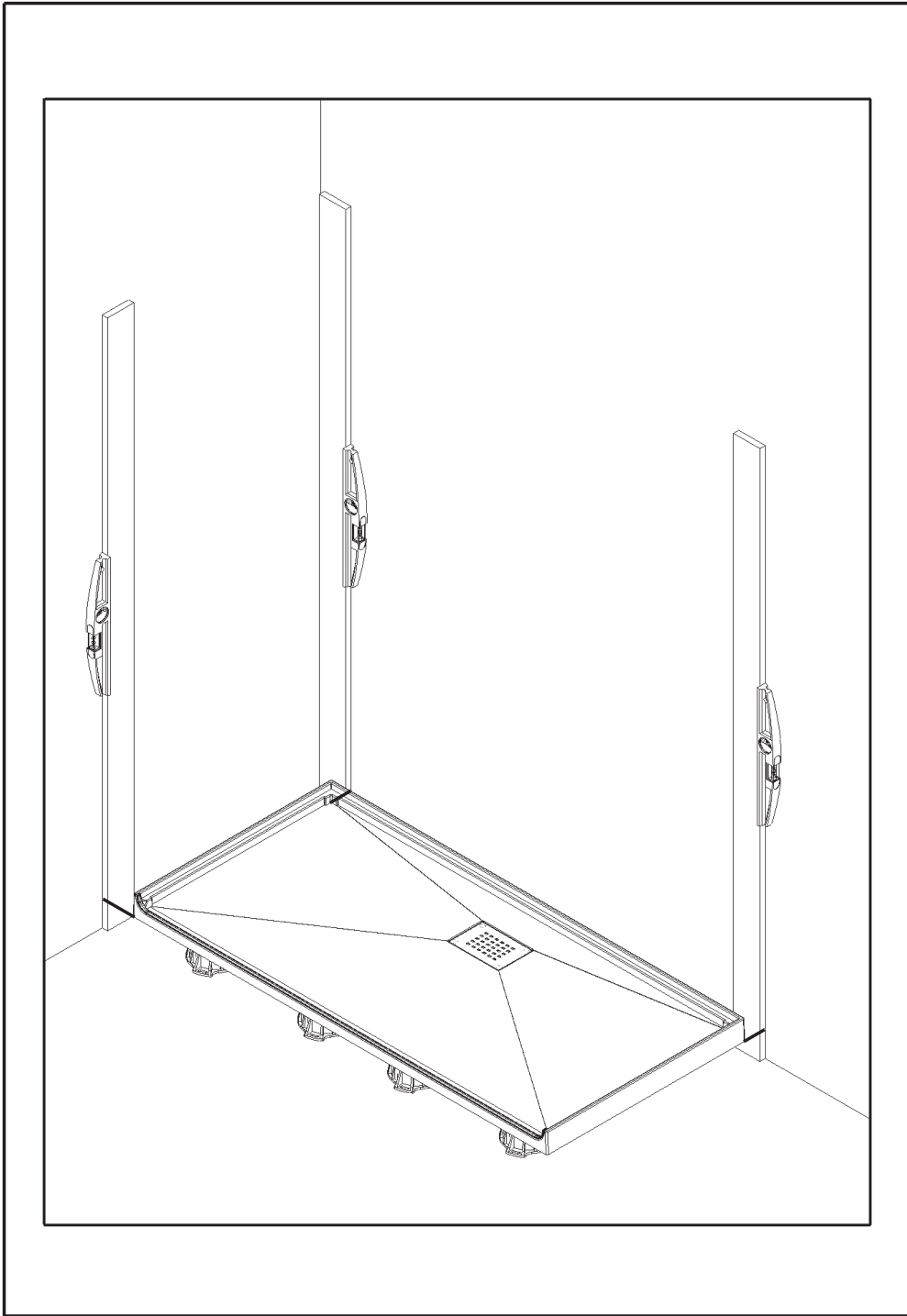

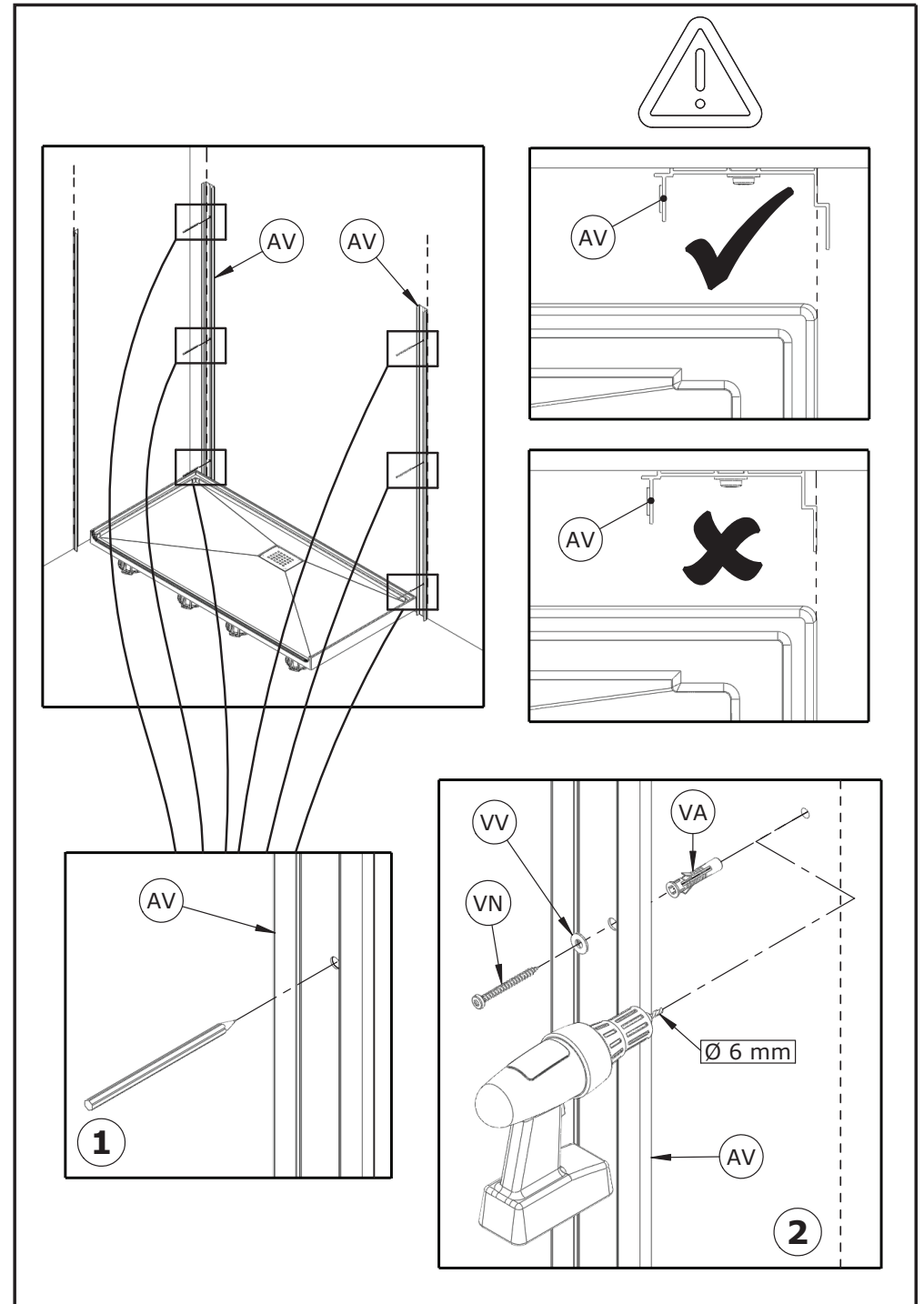
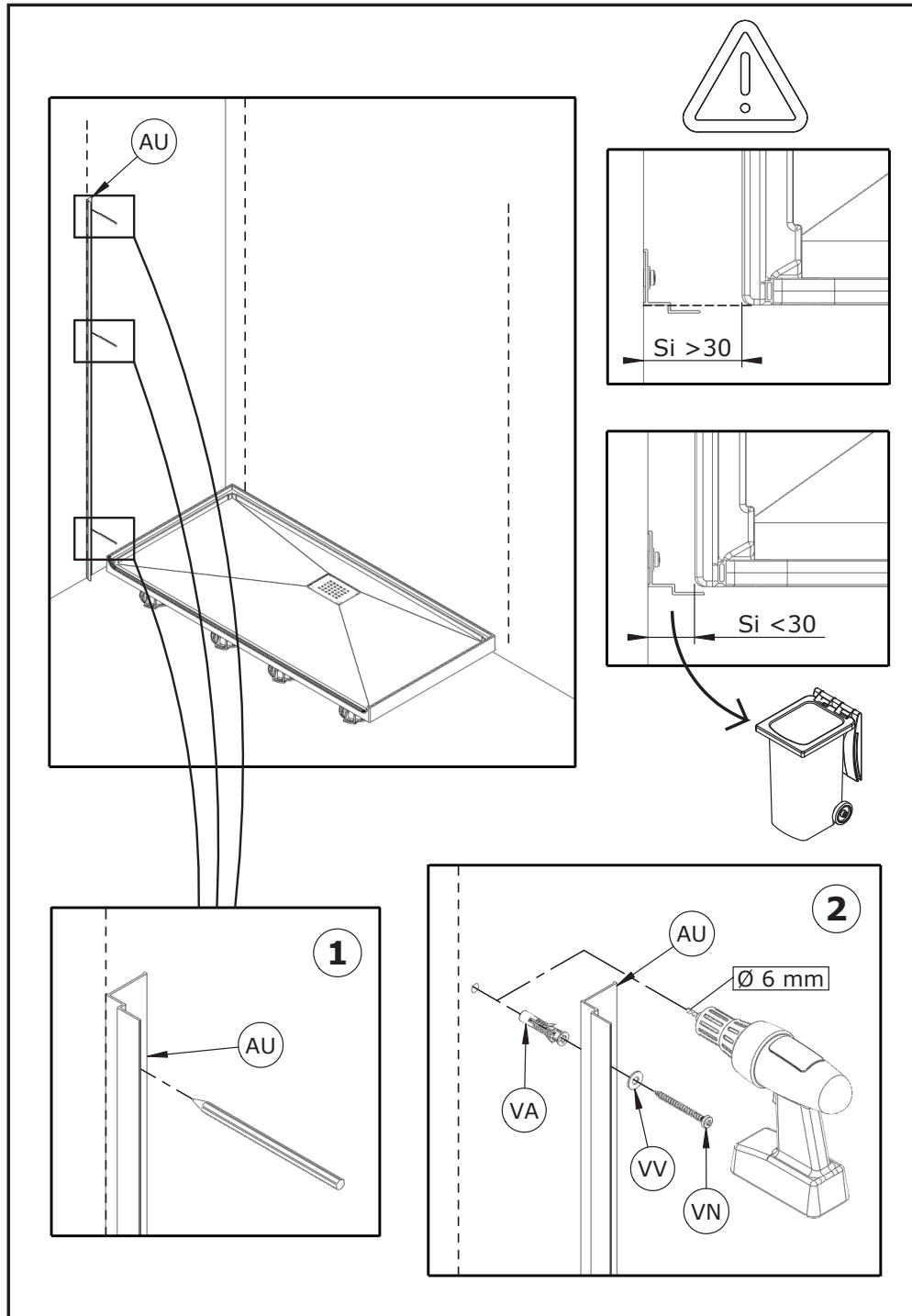

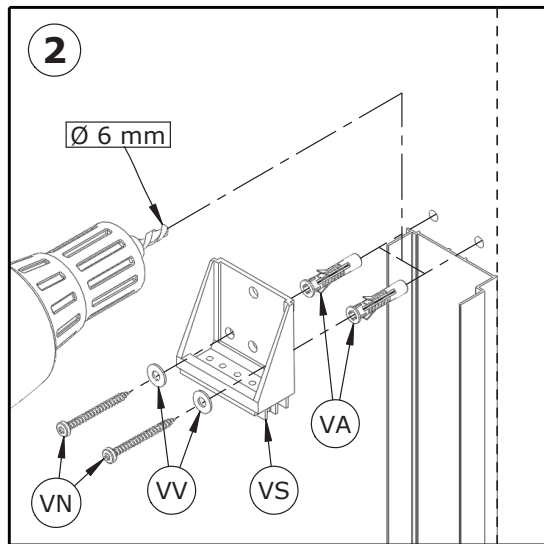
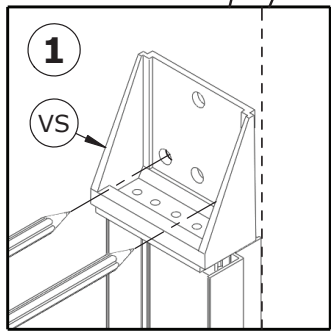
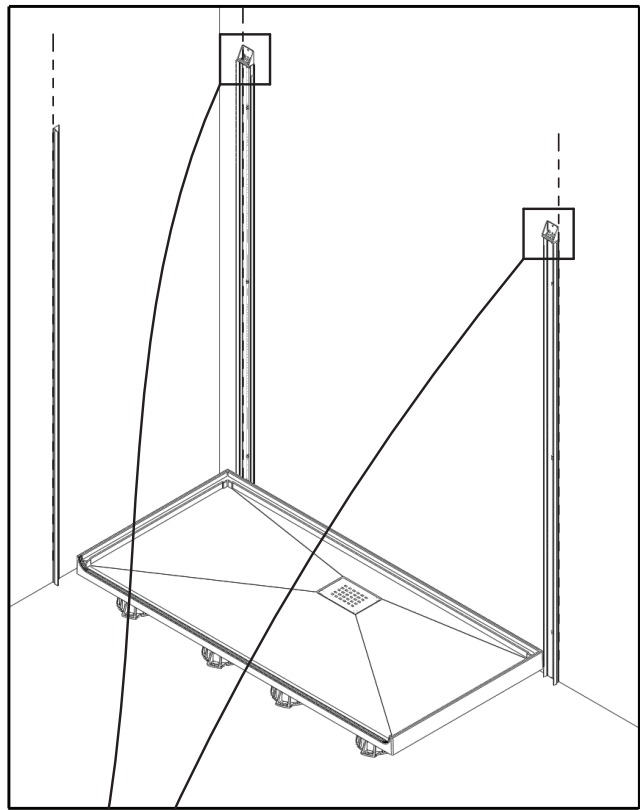

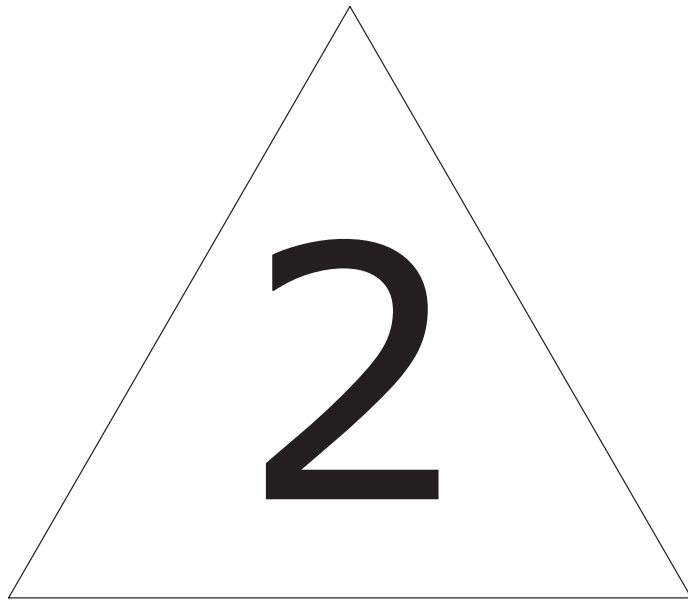

DES1214AG-D

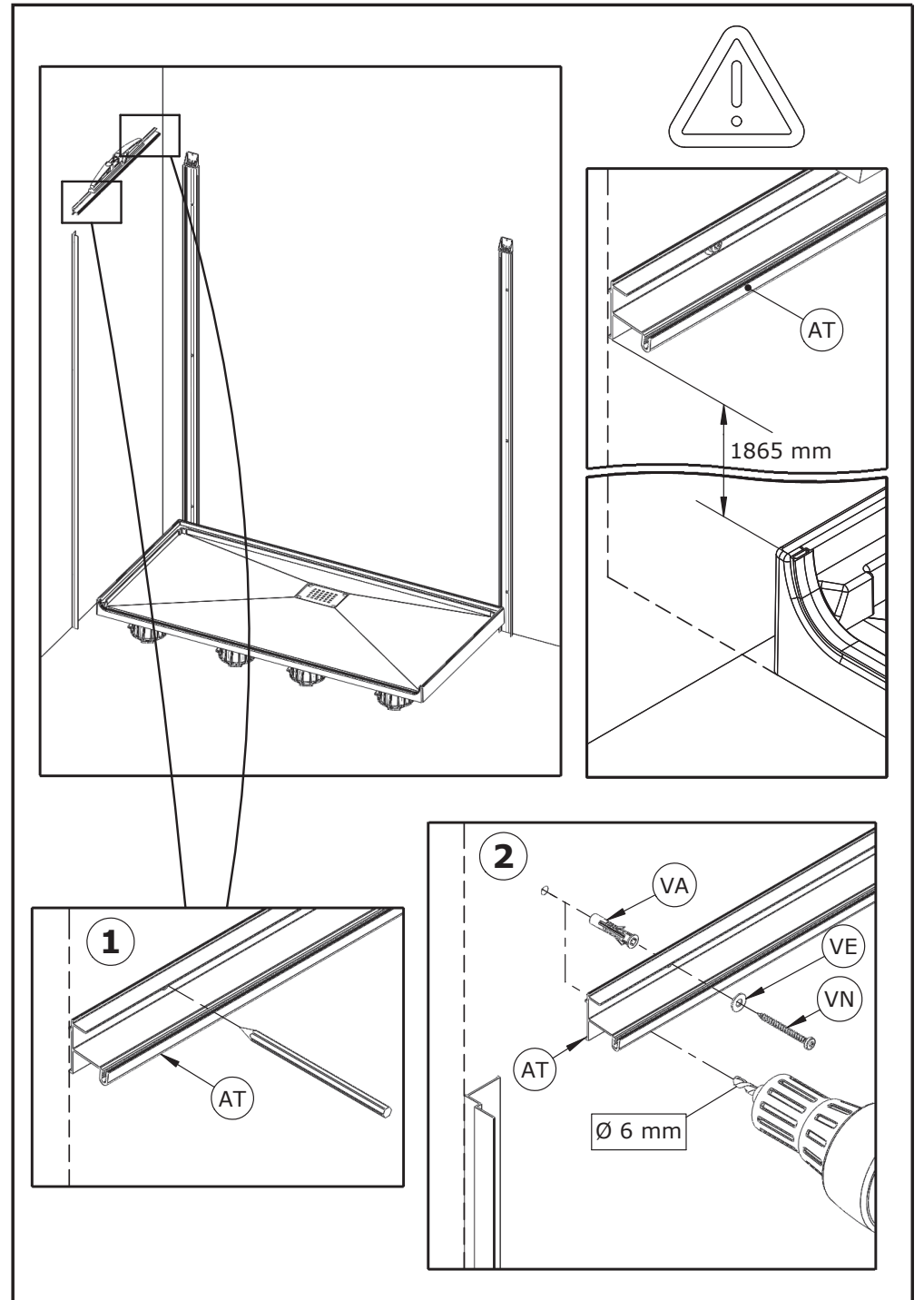

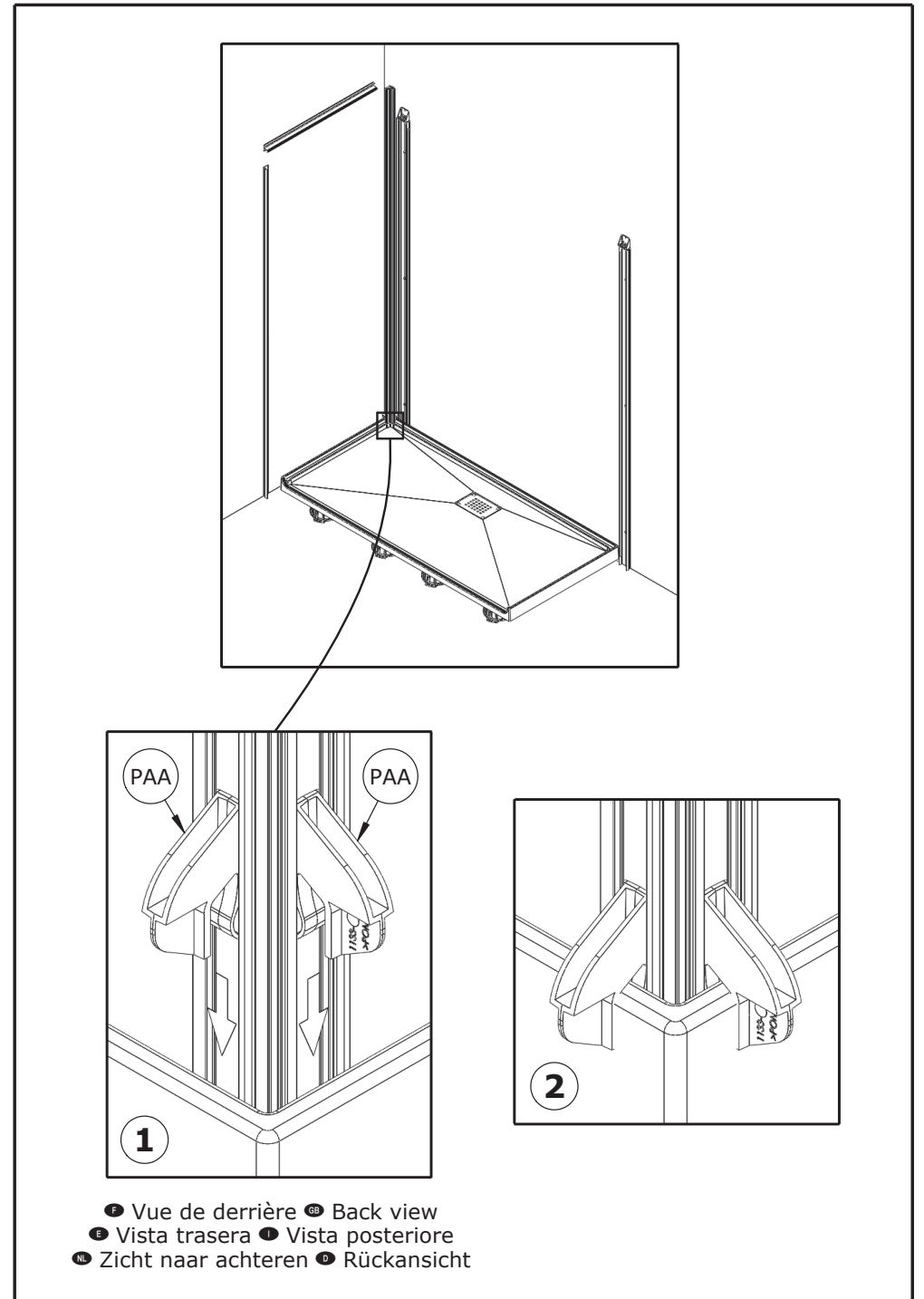
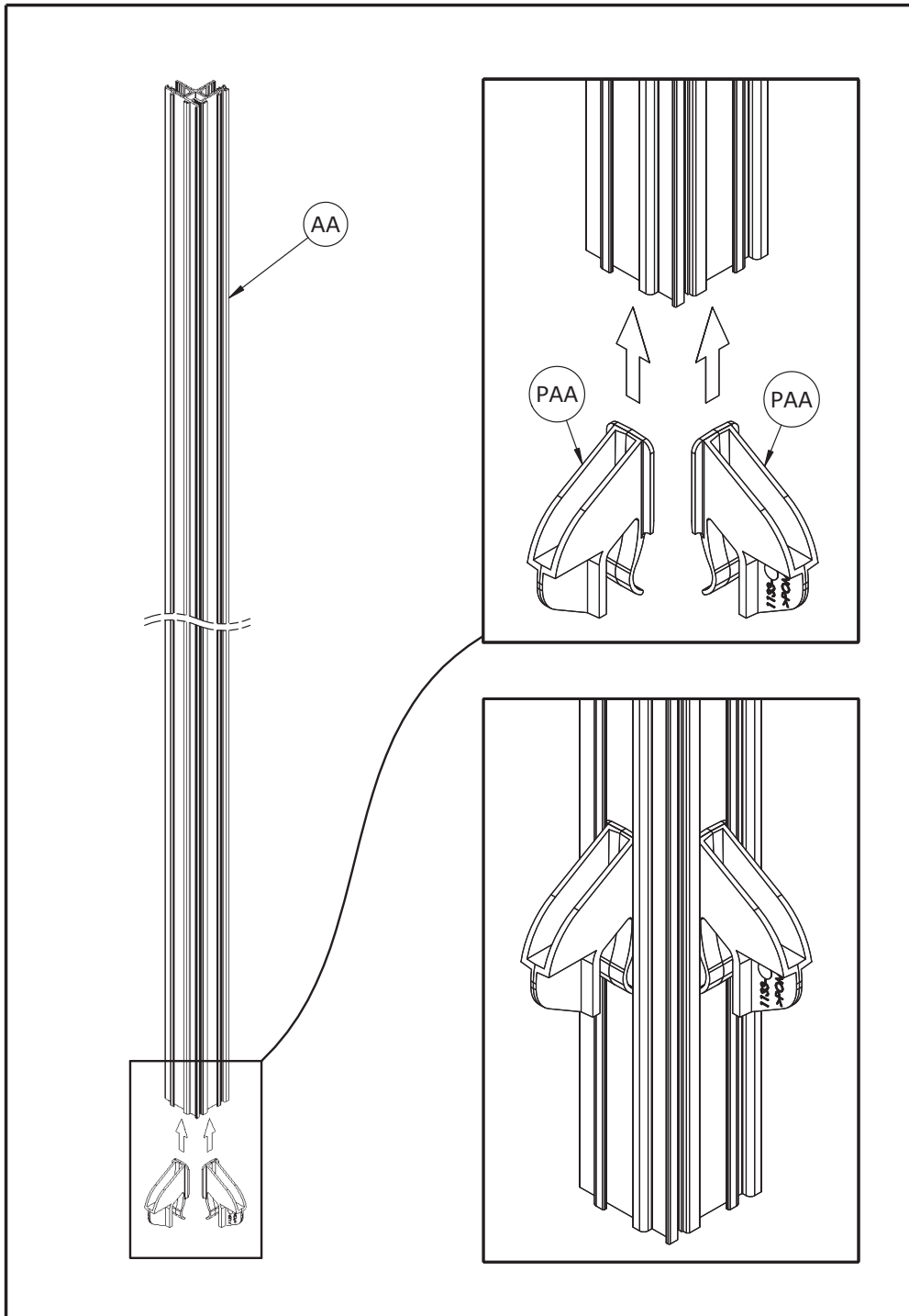

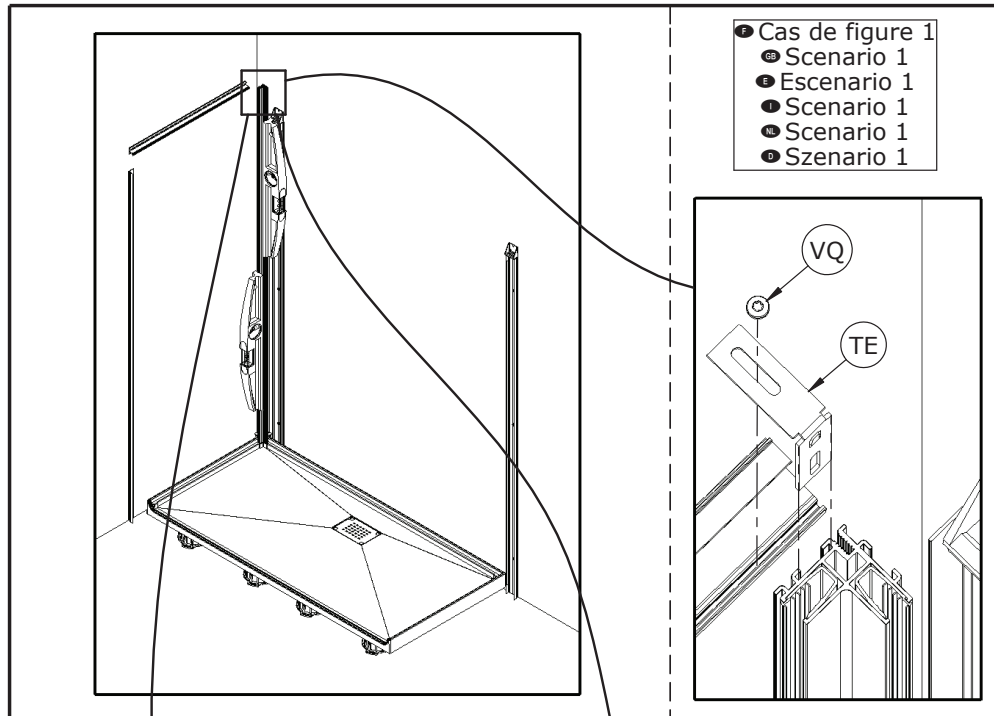

- Cas de figure 1
- Scenario 1
- Escenario 1
- Scenario 1
- Scenario 1
- Szenario 1

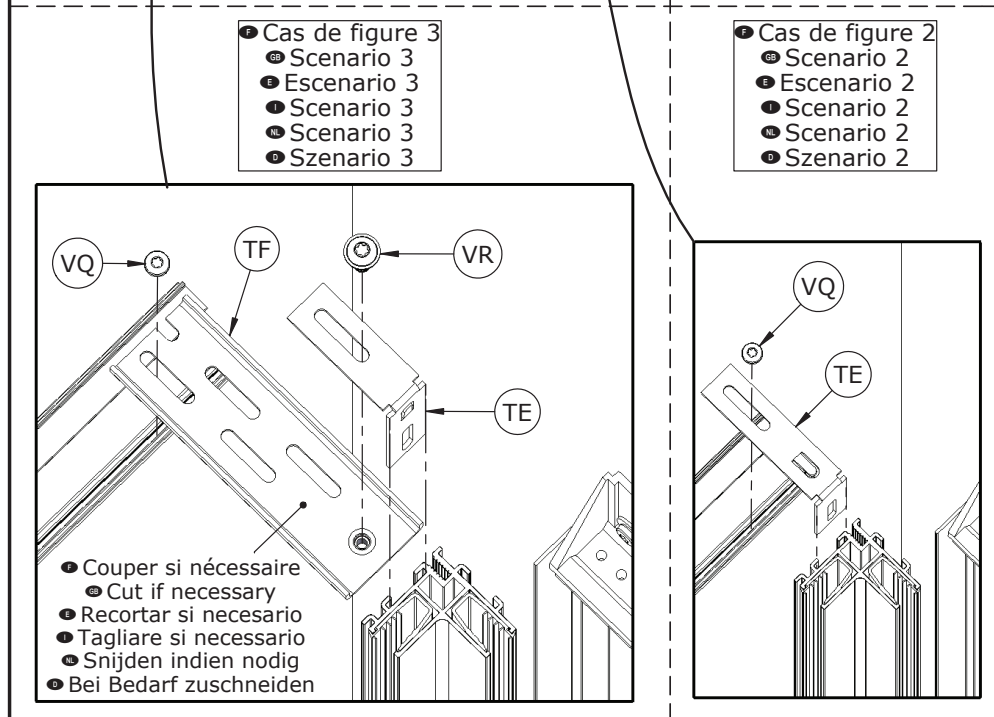

- Cas de figure 3
- Scenario 3
- Escenario 3
- Scenario 3
- Scenario 3
- Szenario 3

- Cas de figure 2
- Scenario 2
- Escenario 2
- Scenario 2
- Scenario 2
- Szenario 2

- Couper si nécessaire
- Cut if necessary
- Recortar si necesario
- Tagliare si necessario
- Snijden indien nodig
- Bei Bedarf zuschneiden

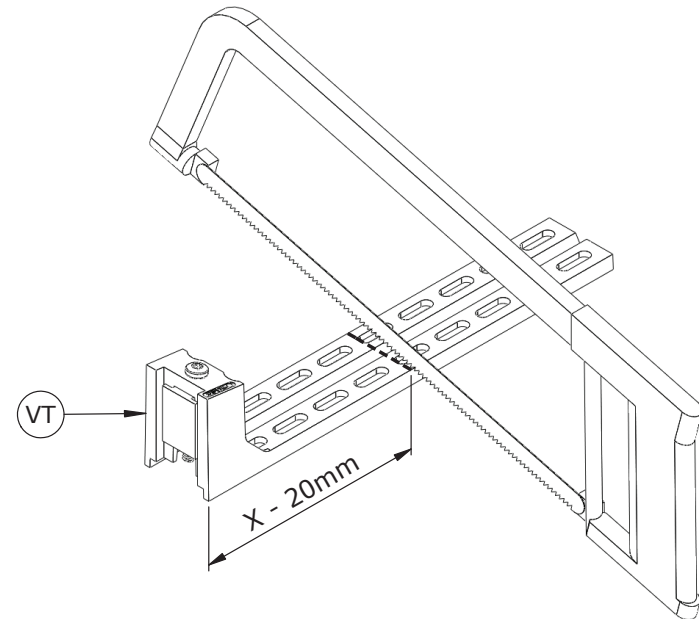
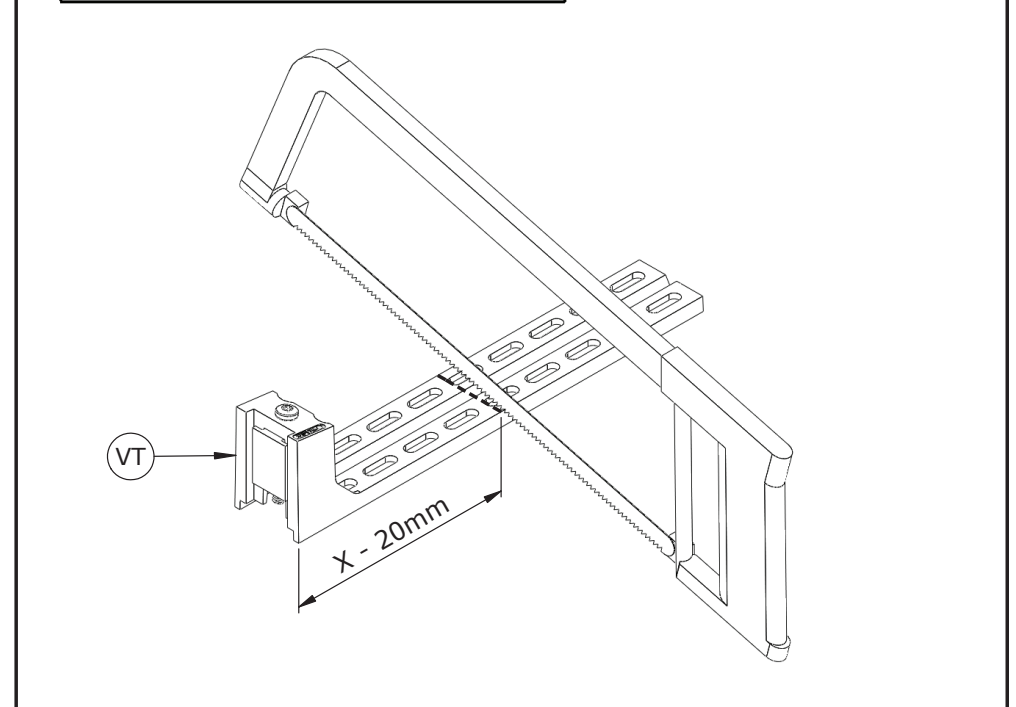
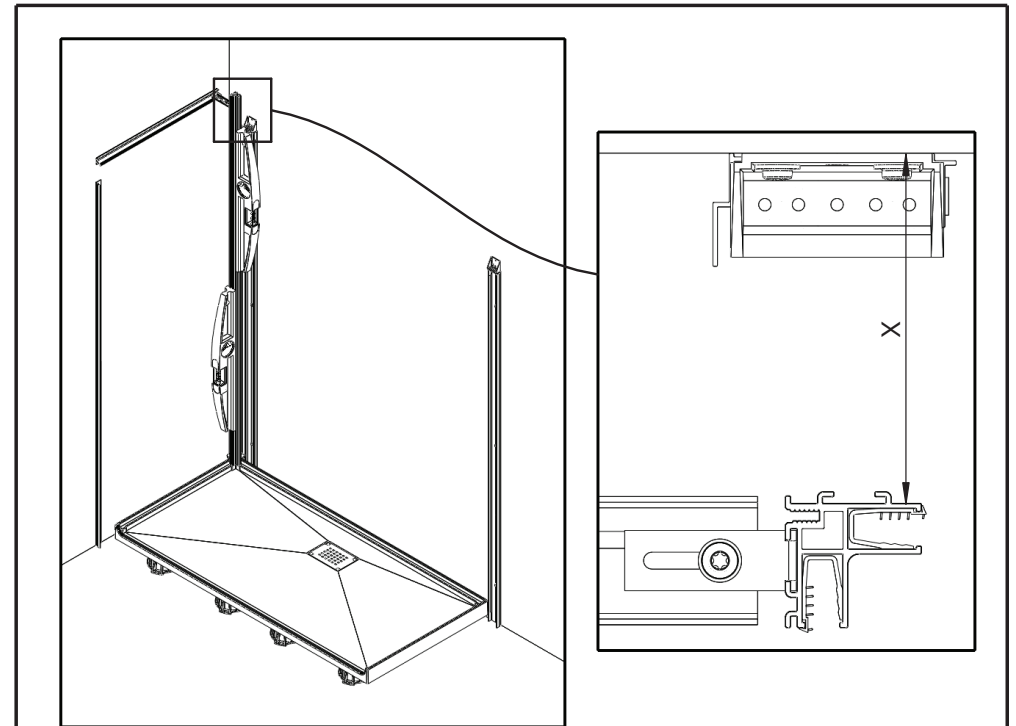

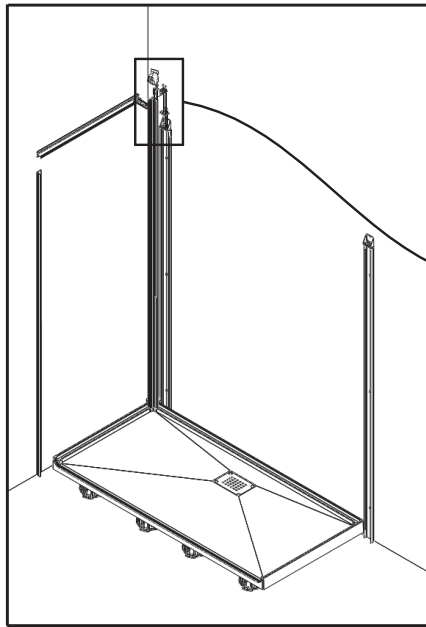

- Ⓐ Serrer Ⓜ Tighten
- Ⓑ Apriete Ⓝ Serrare
- Ⓒ Festziehen Ⓟ Aandraaien

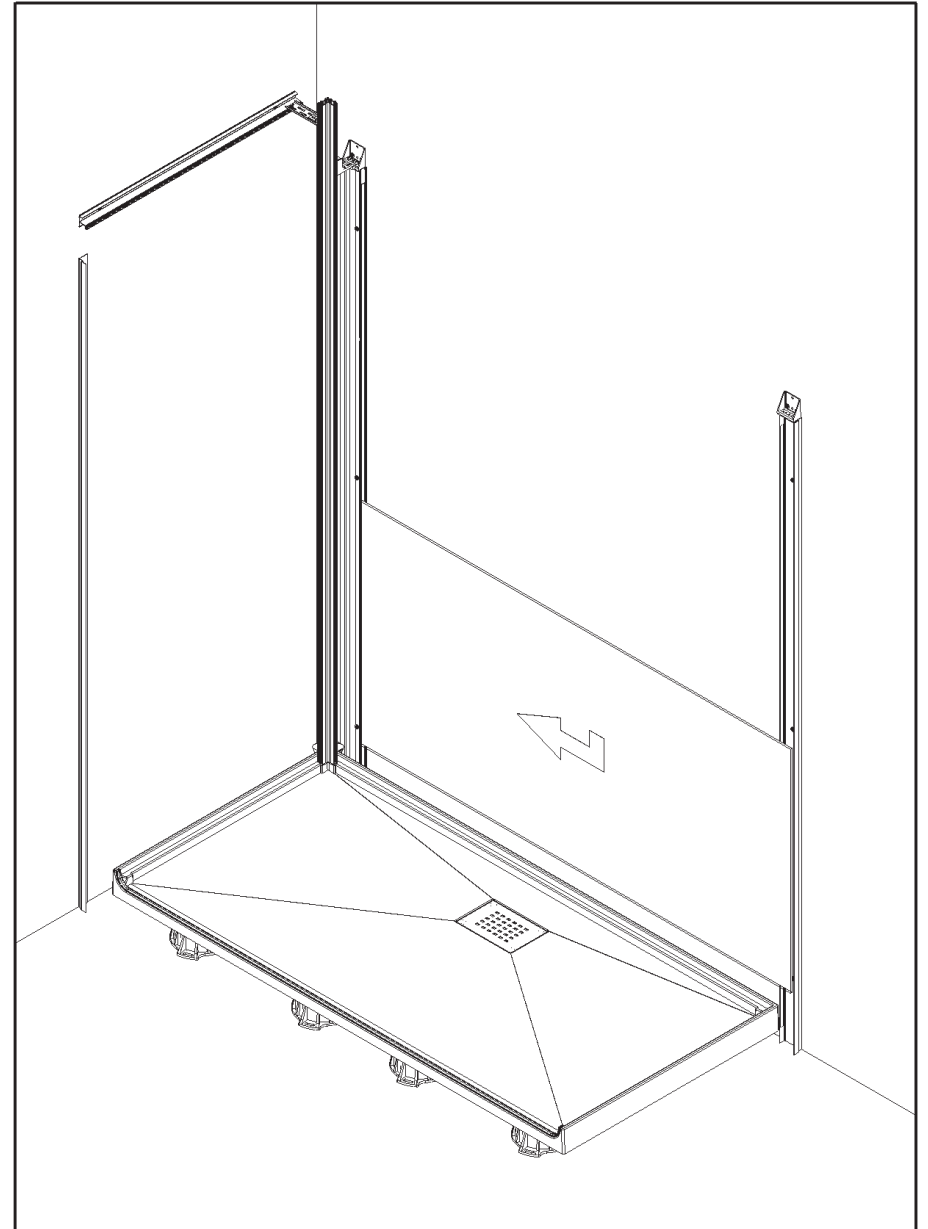
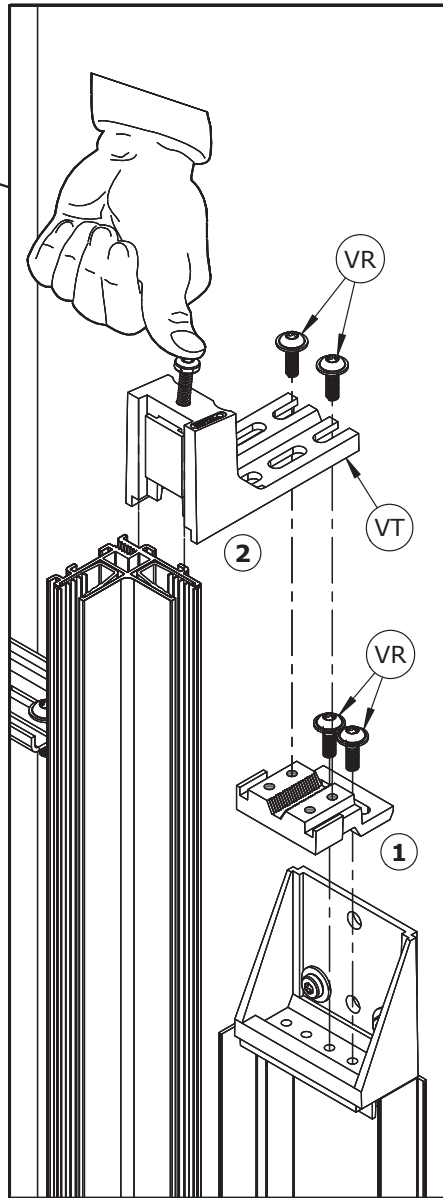
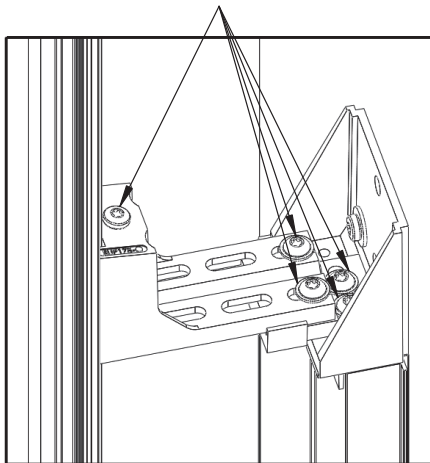

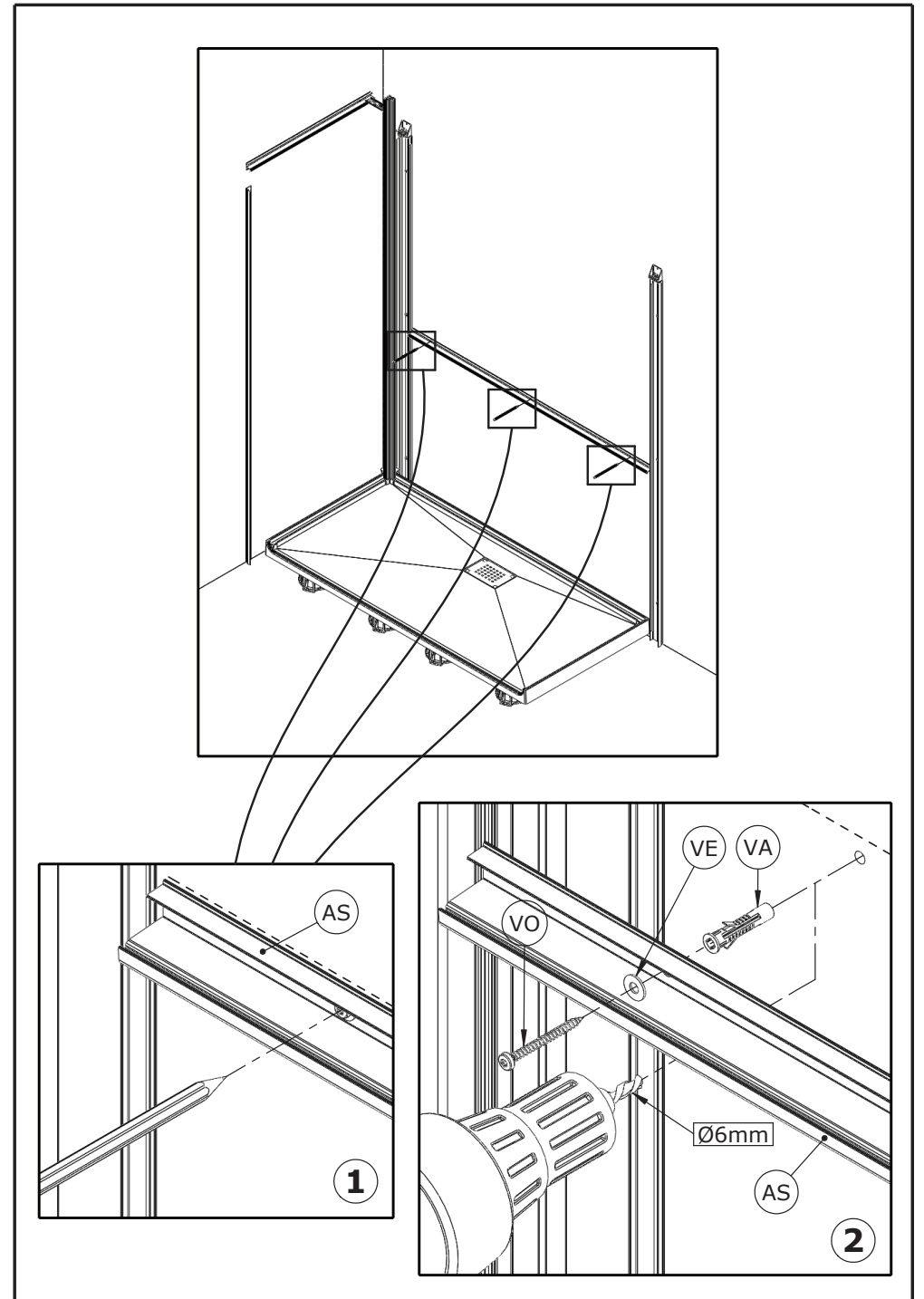
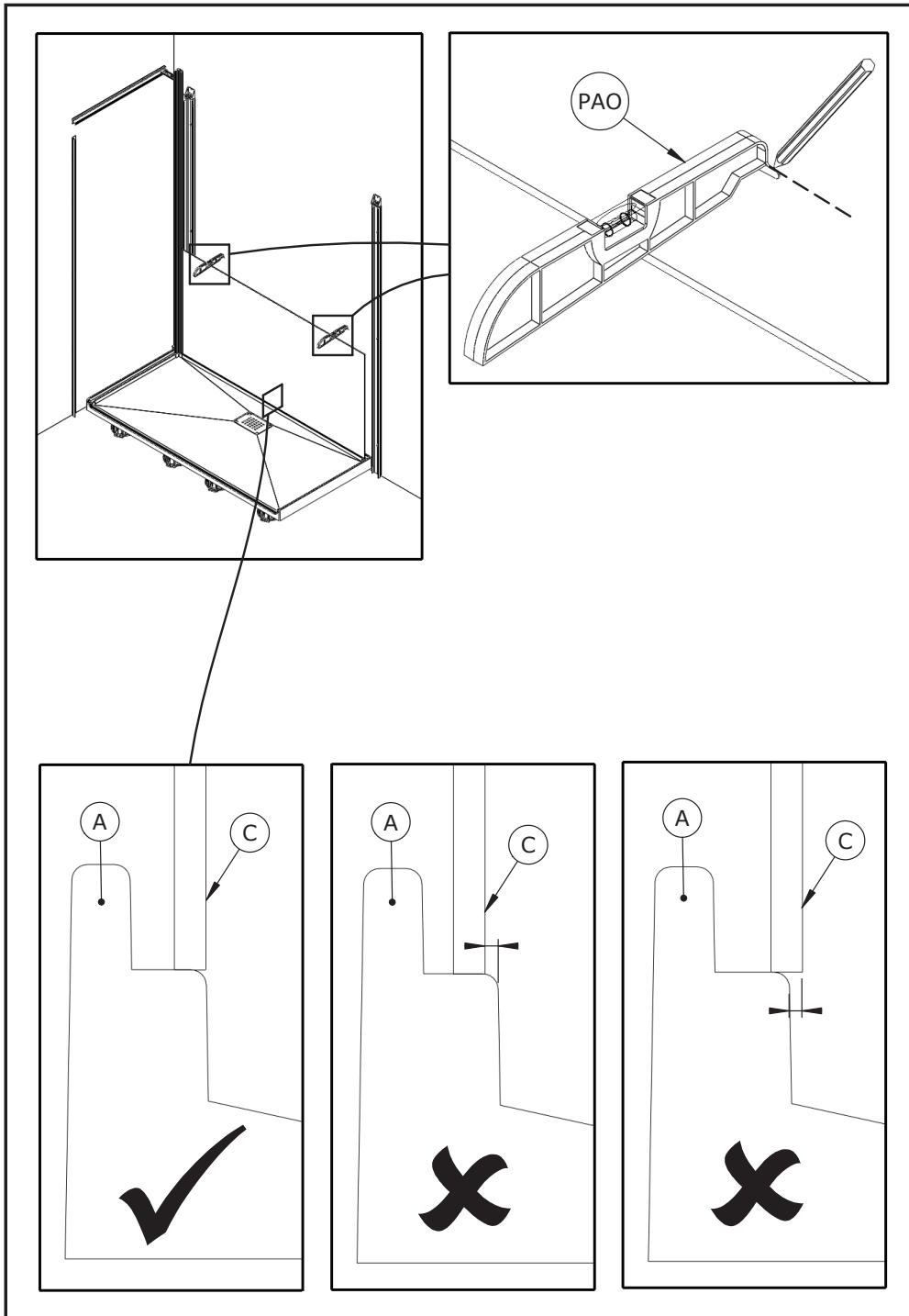

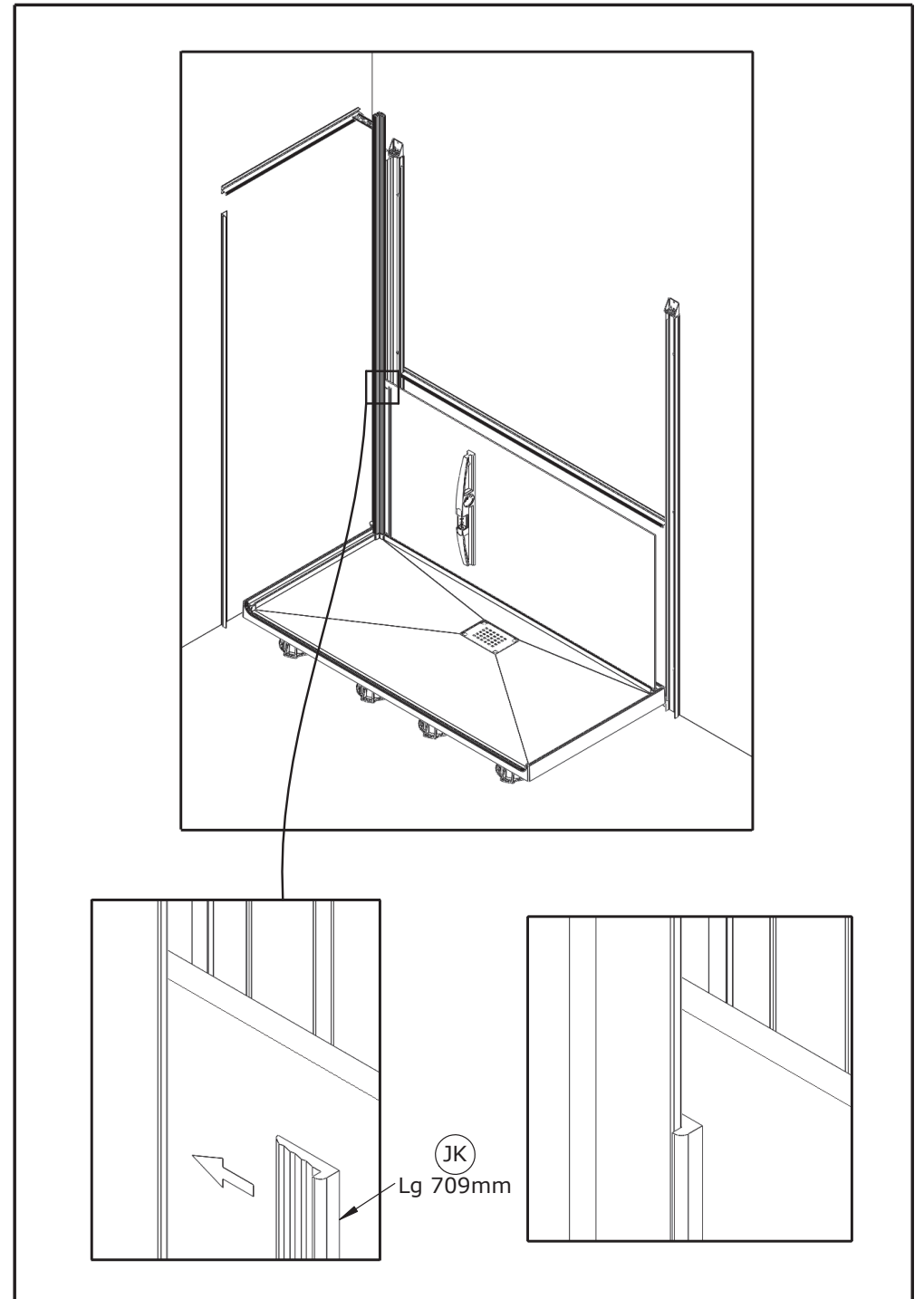
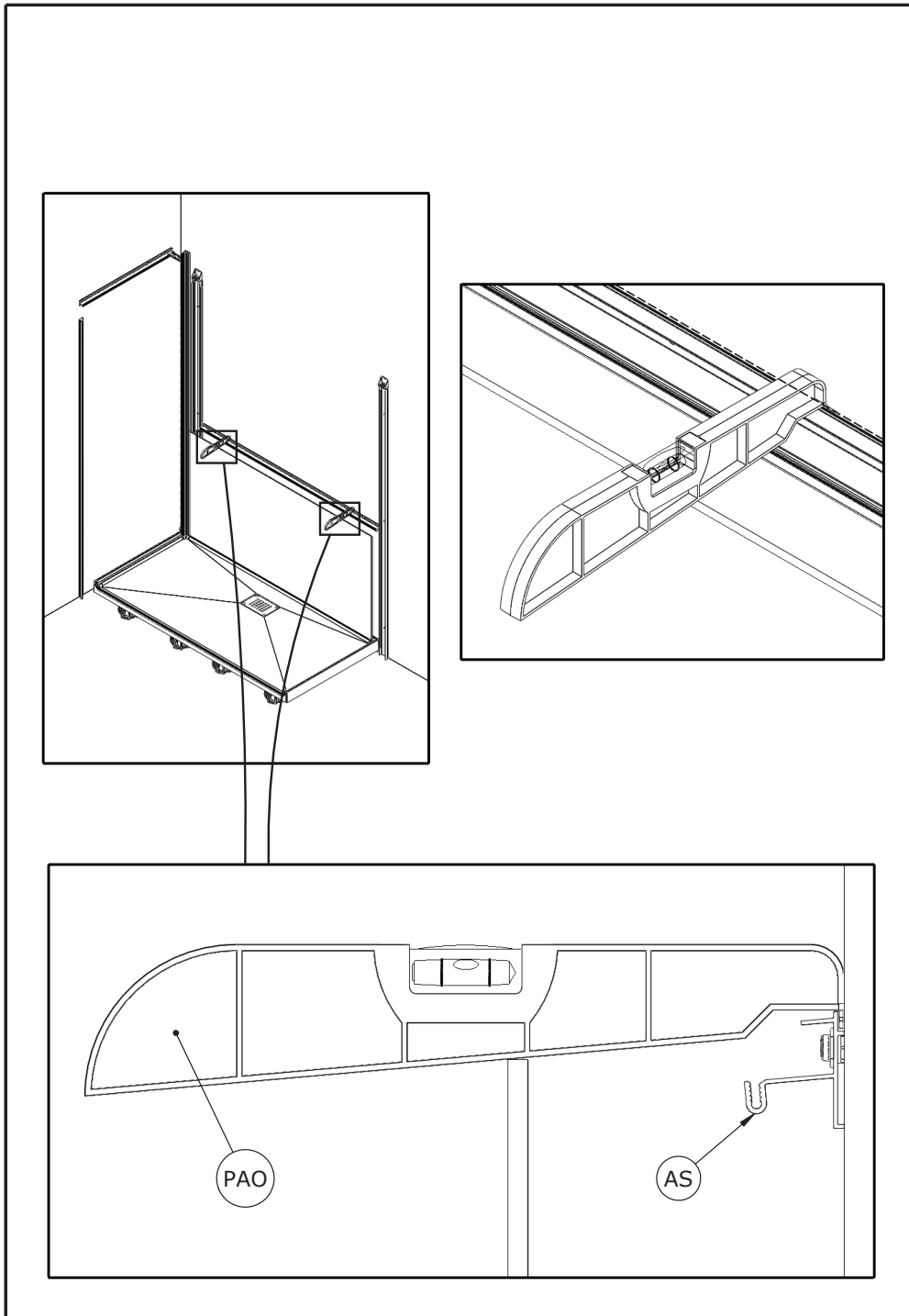

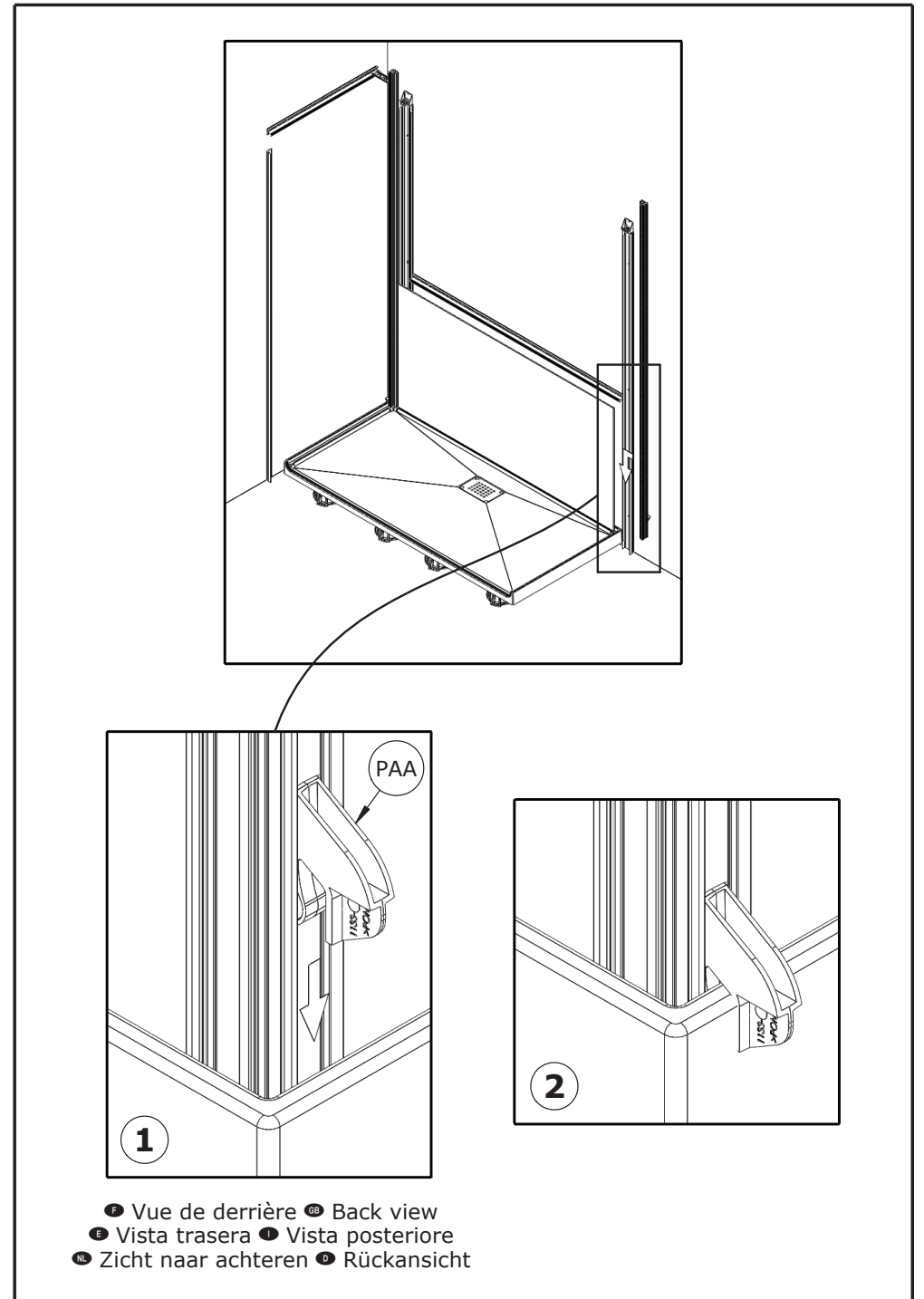
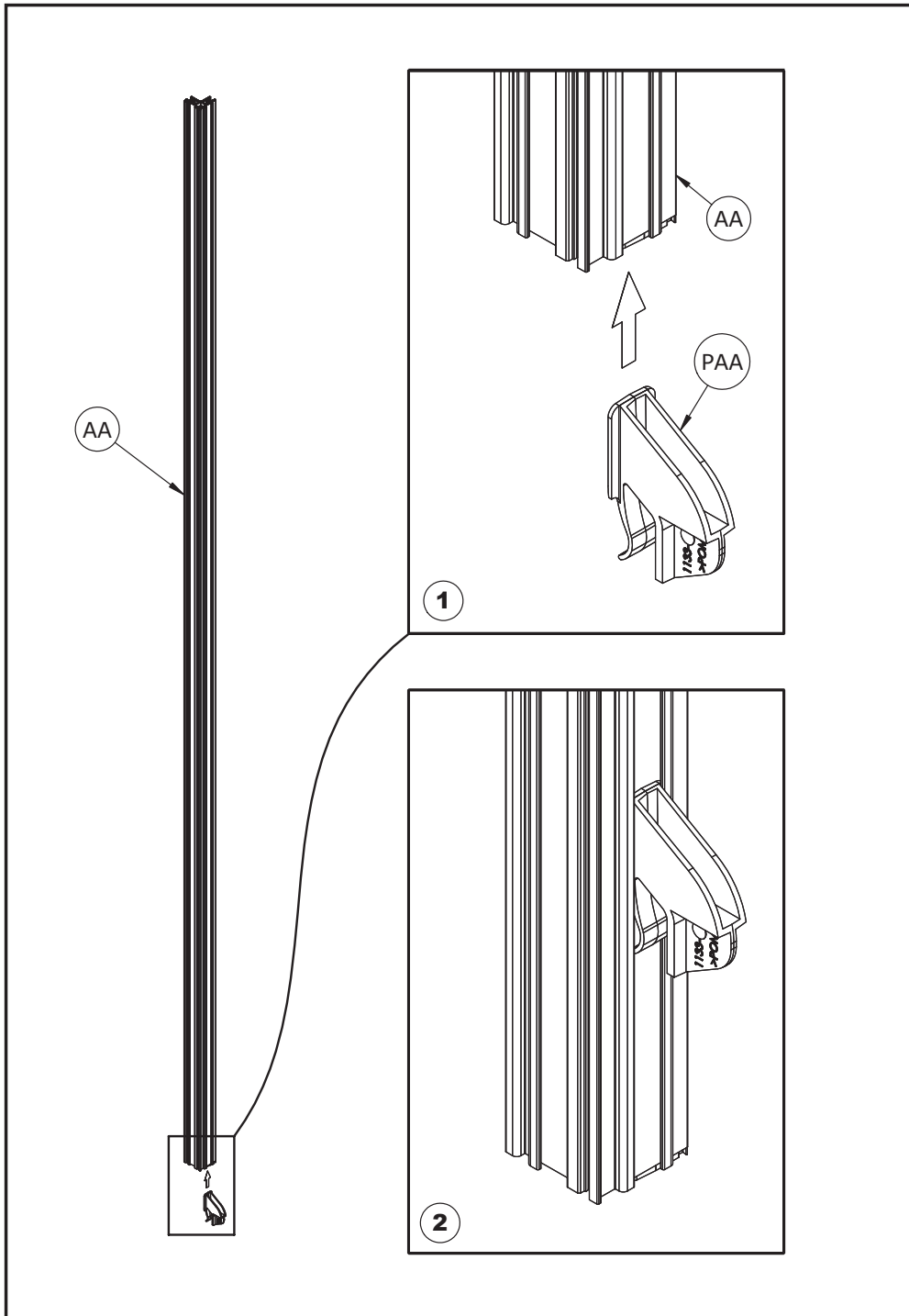

- F Vue de derrière ● GB Back view
- E Vista trasera ● I Vista posteriore
- NL Zicht naar achteren ● D Rückansicht

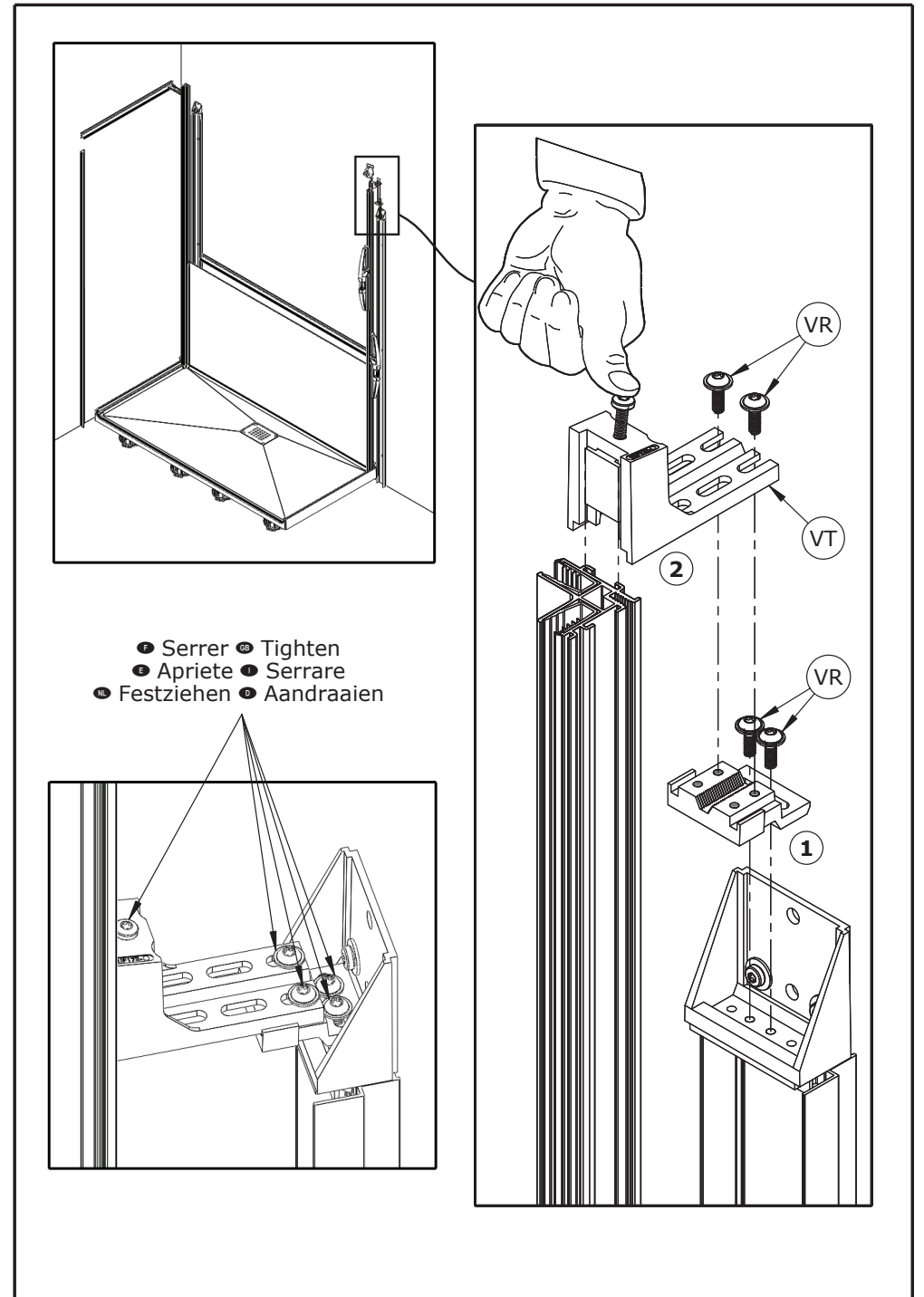
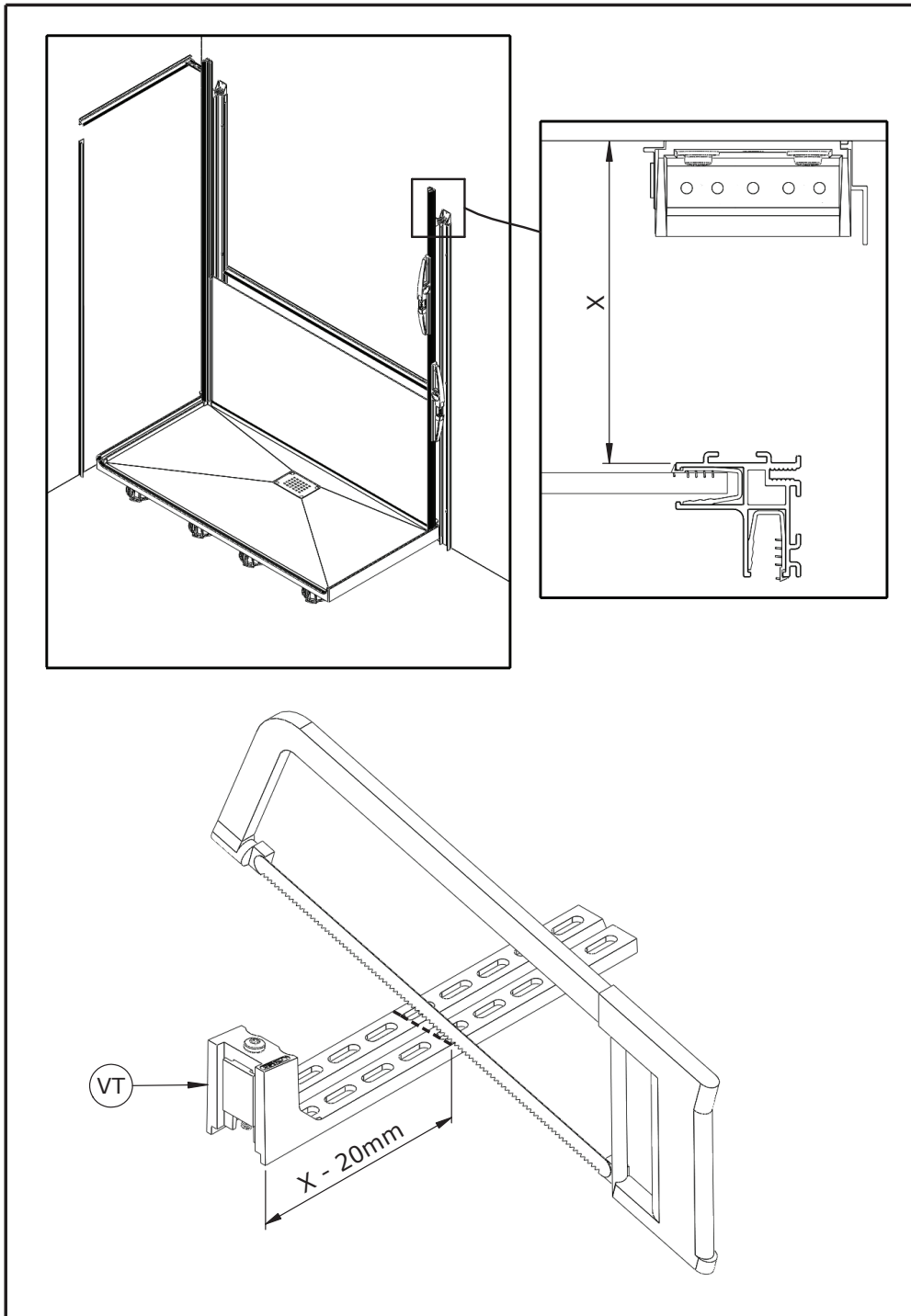

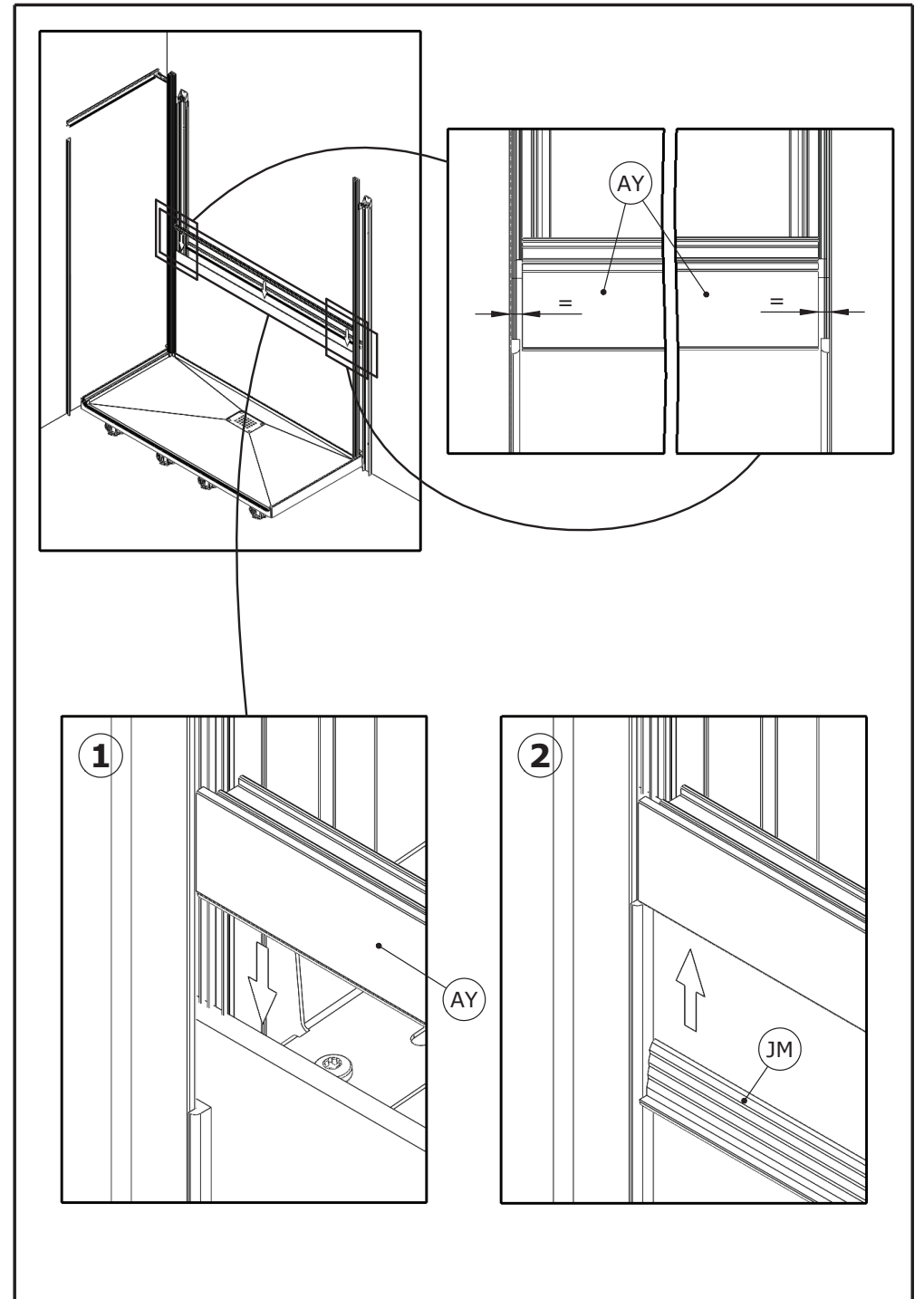
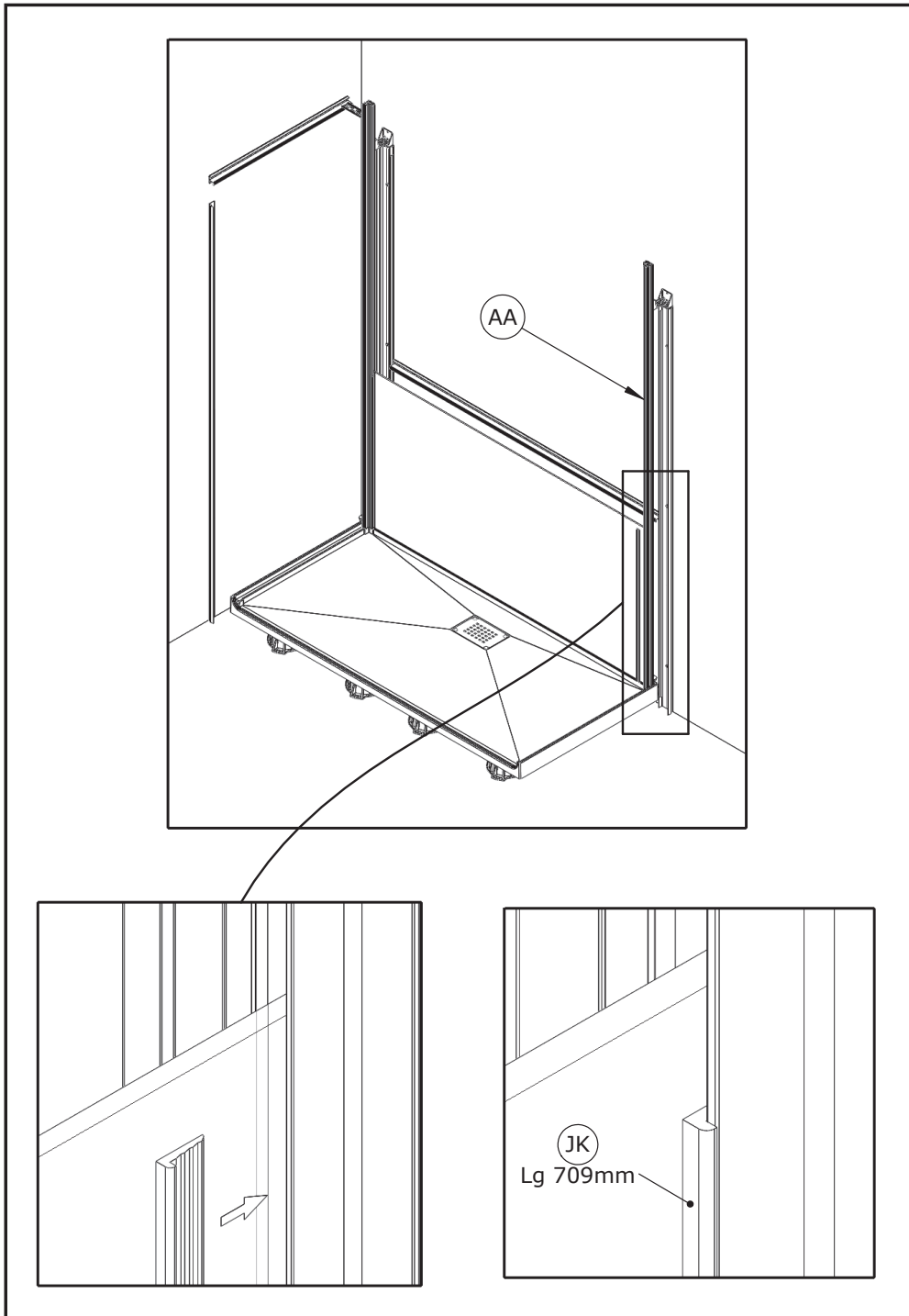

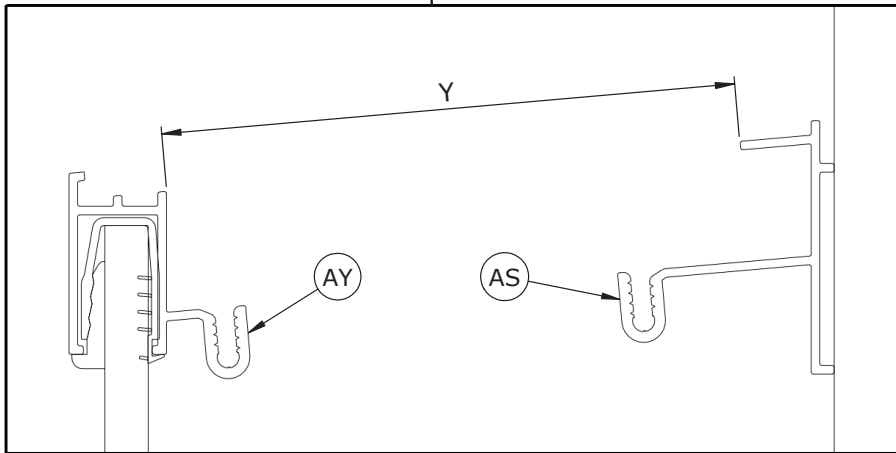
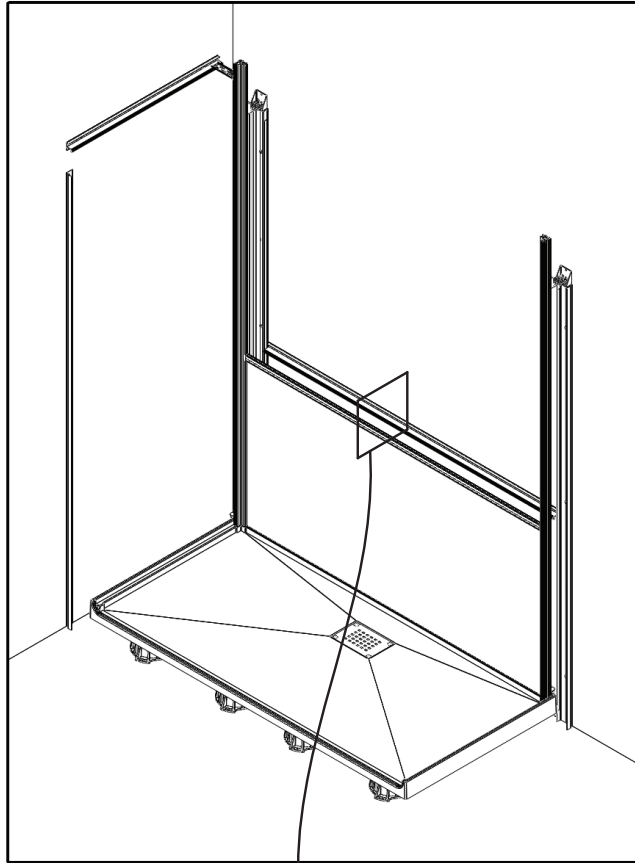

ⓘ Attention au sens ⓘ Attention to the direction
ⓘ Atención a la dirección ⓘ Attenzione alla direzione
ⓘ Let op het gevoel ⓘ Richtung beachten

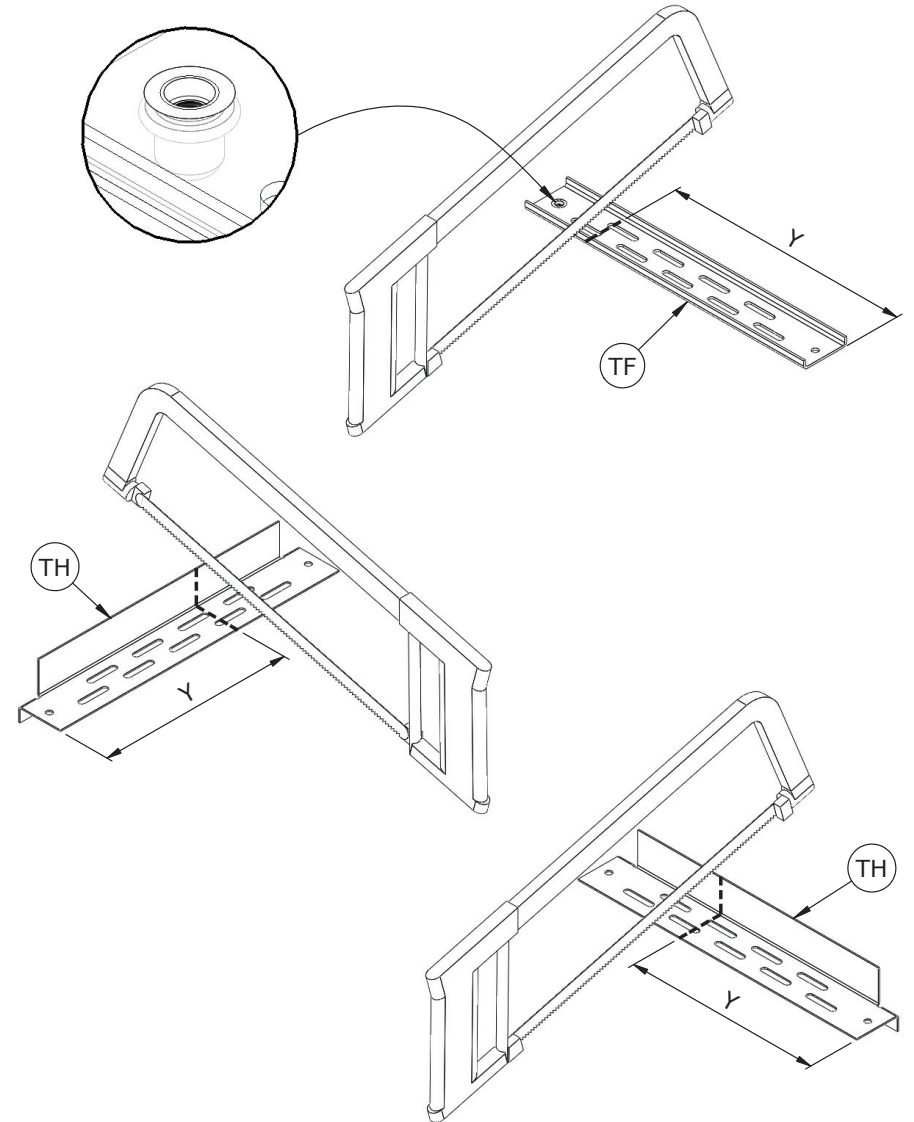

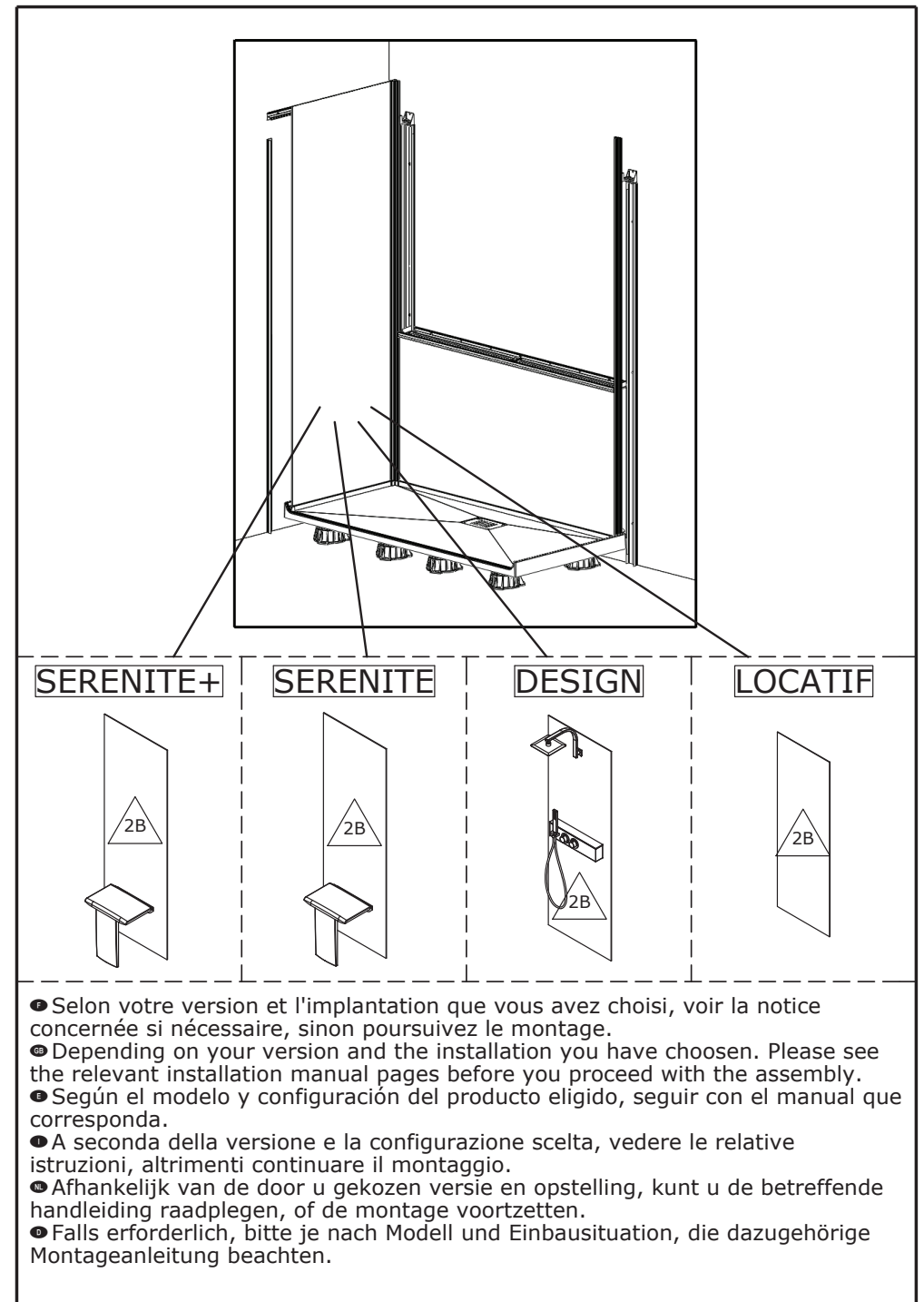
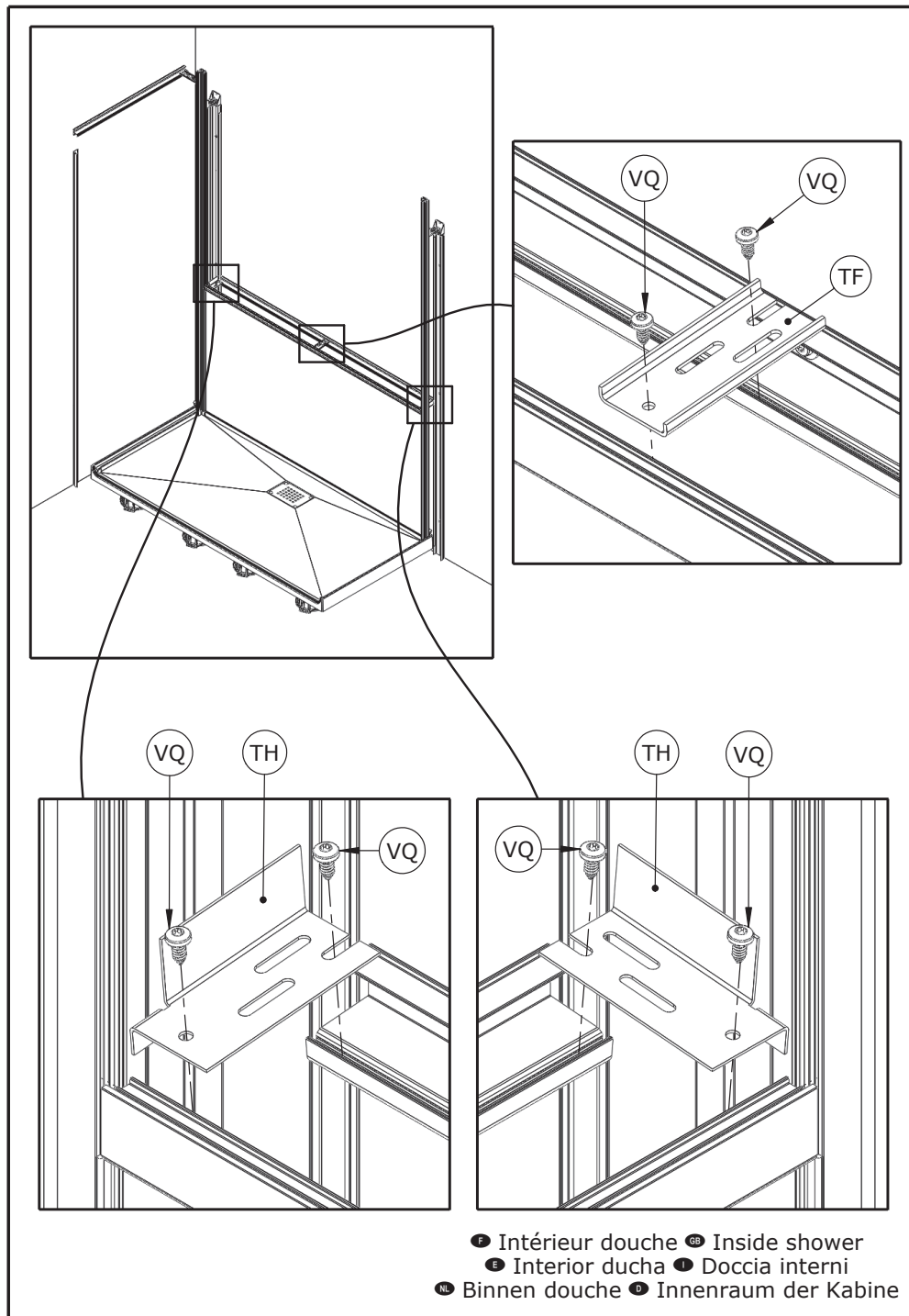

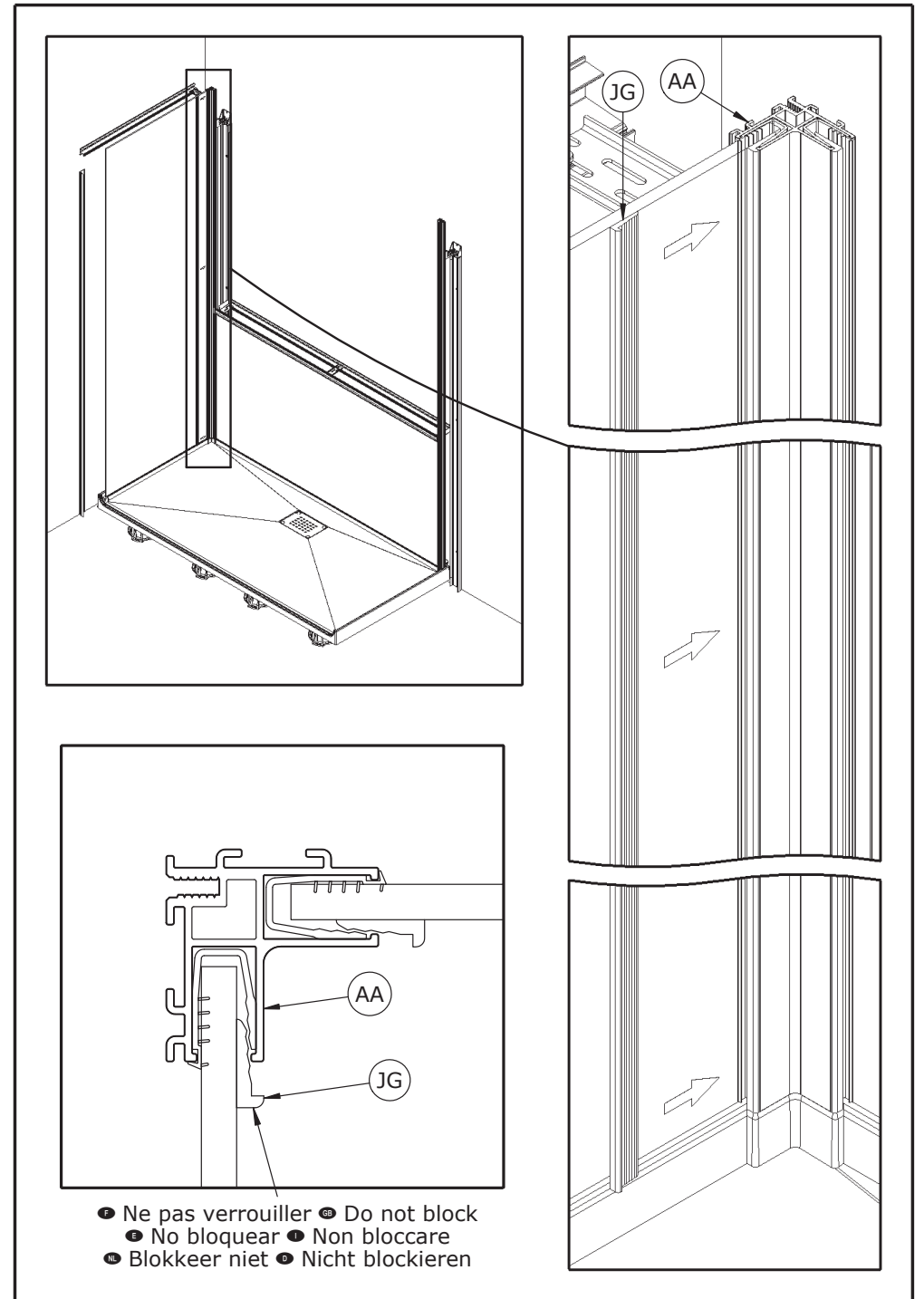
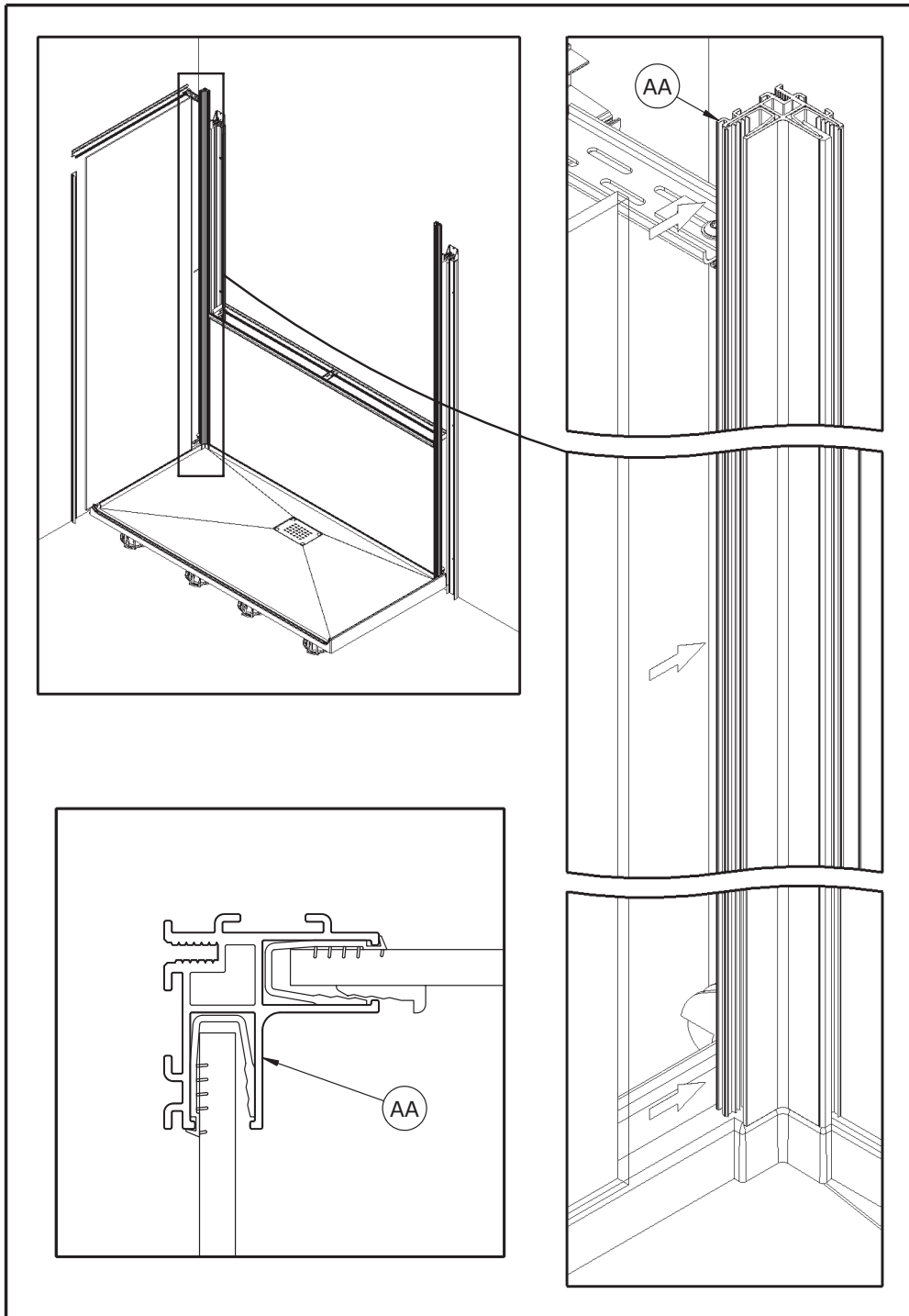



DES1198AG-G

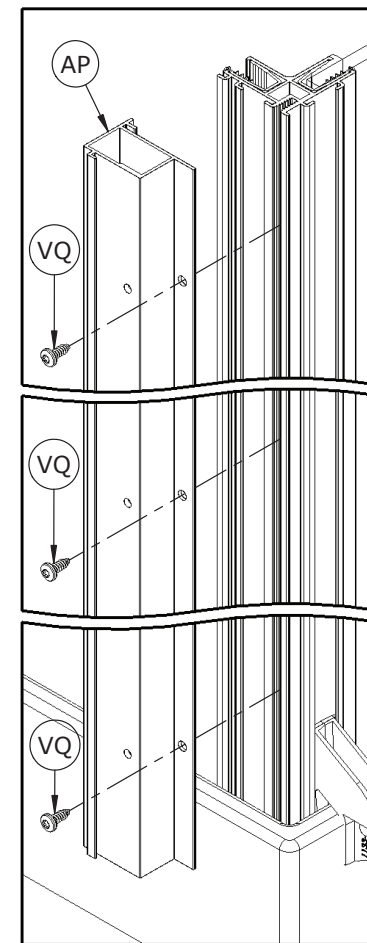
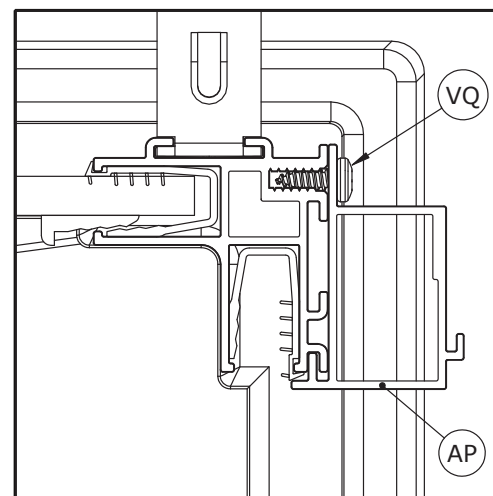
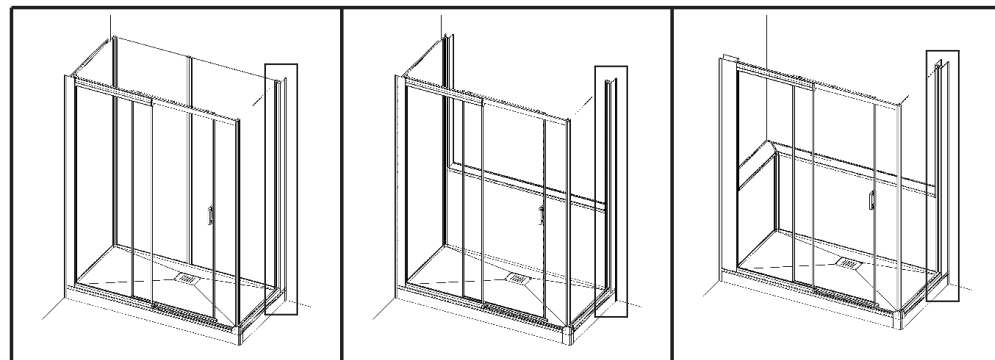

F ● Vue de derrière GB ● Back view
 E ● Vista trasera I ● Vista posteriore
 NL ● Zicht naar achteren D ● Rückansicht

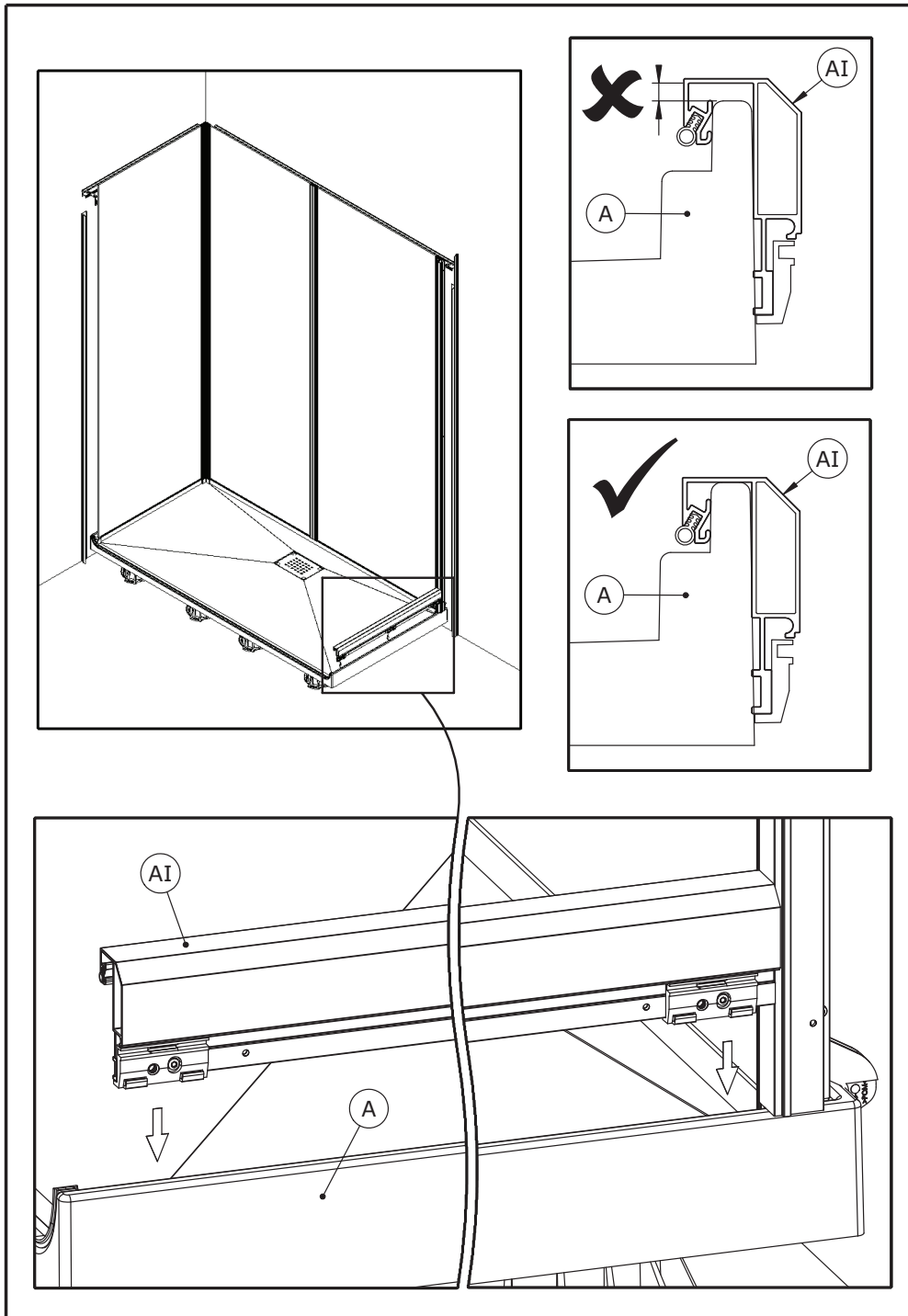

SERENITE+	SERENITE	DESIGN	LOCATIF
<ul style="list-style-type: none"> Ⓕ Bas ⒼⓈ Down Ⓔ Bajo Ⓕ Basso Ⓜ Laag Ⓡ Runter 	<ul style="list-style-type: none"> Ⓕ Bas ⒼⓈ Down Ⓔ Bajo Ⓕ Basso Ⓜ Laag Ⓡ Runter 		<ul style="list-style-type: none"> Ⓕ Bas ⒼⓈ Down Ⓔ Bajo Ⓕ Basso Ⓜ Laag Ⓡ Runter

● Selon votre version et l'implantation que vous avez choisi, voir la notice concernée si nécessaire, sinon poursuivez le montage.
 ● Depending on your version and the installation you have chosen. Please see the relevant installation manual pages before you proceed with the assembly.
 ● Según el modelo y configuración del producto elegido, seguir con el manual que corresponda.
 ● A seconda della versione e la configurazione scelta, vedere le relative istruzioni, altrimenti continuare il montaggio.
 ● Afhankelijk van de door u gekozen versie en opstelling, kunt u de betreffende handleiding raadplegen, of de montage voortzetten.
 ● Falls erforderlich, bitte je nach Modell und Einbausituation, die dazugehörige Montageanleitung beachten.

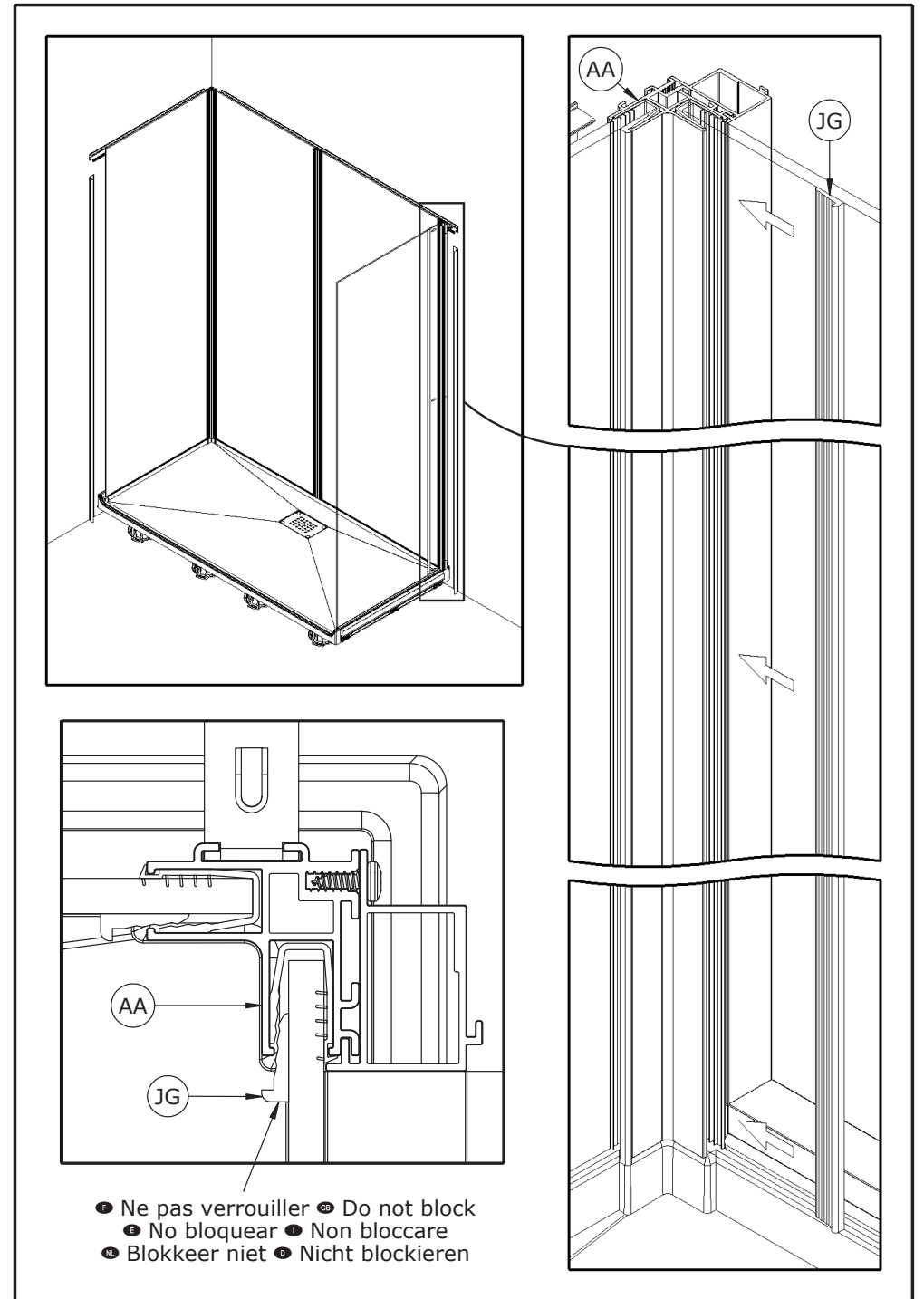
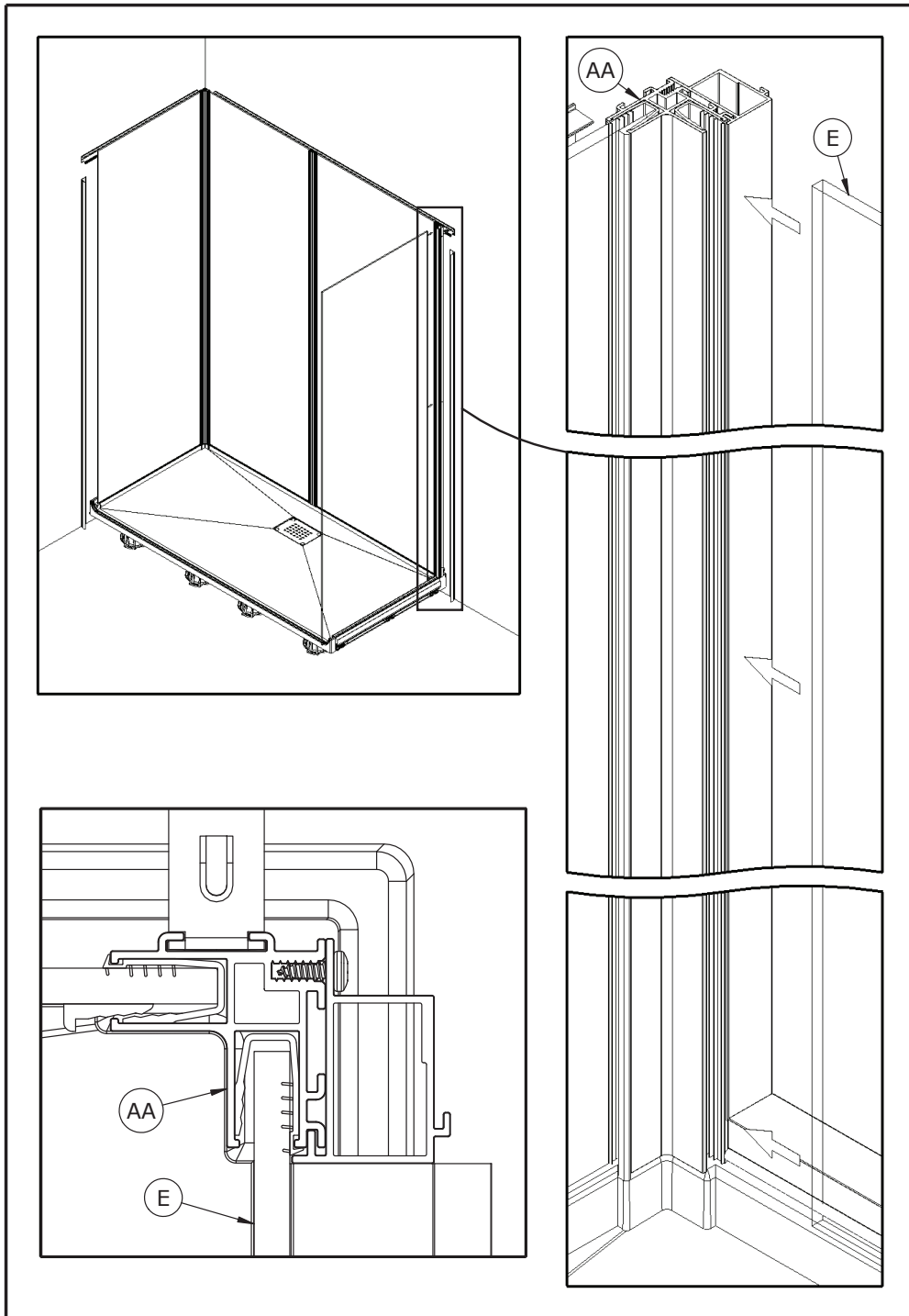

- Ne pas verrouiller • Do not block
- No bloquear • Non bloccare
- Blokkeer niet • Nicht blockieren

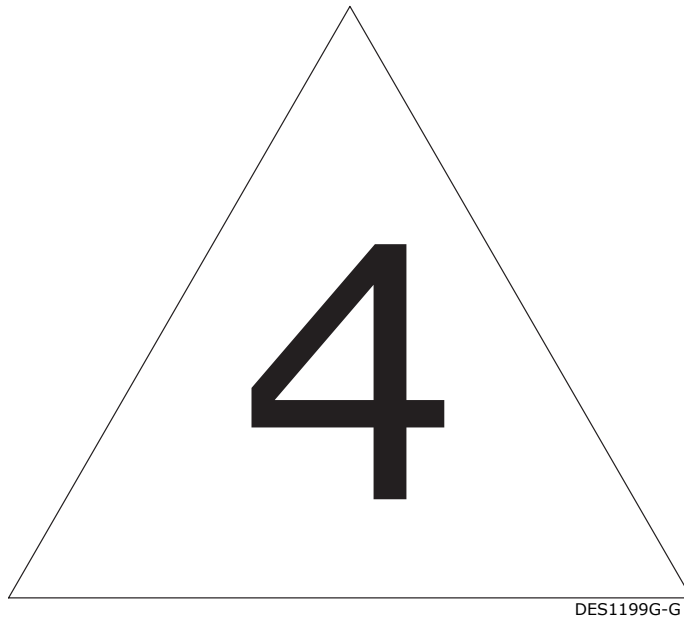

DES1199G-G

- Version ANGLE • CORNER version • Versión entre 2 paredes
- Versione ANGOLO • HOEK uitvoering • ECKVERSION

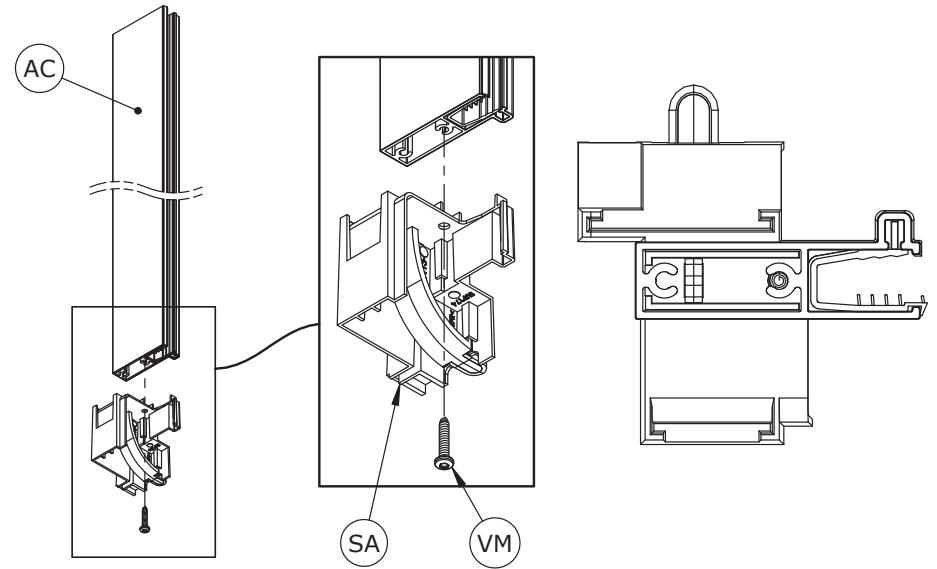

- Version NICHE • RECESS version • Versión entre 3 paredes
- Versione NICCHIA • NIS uitvoering • NISCHENVERSION

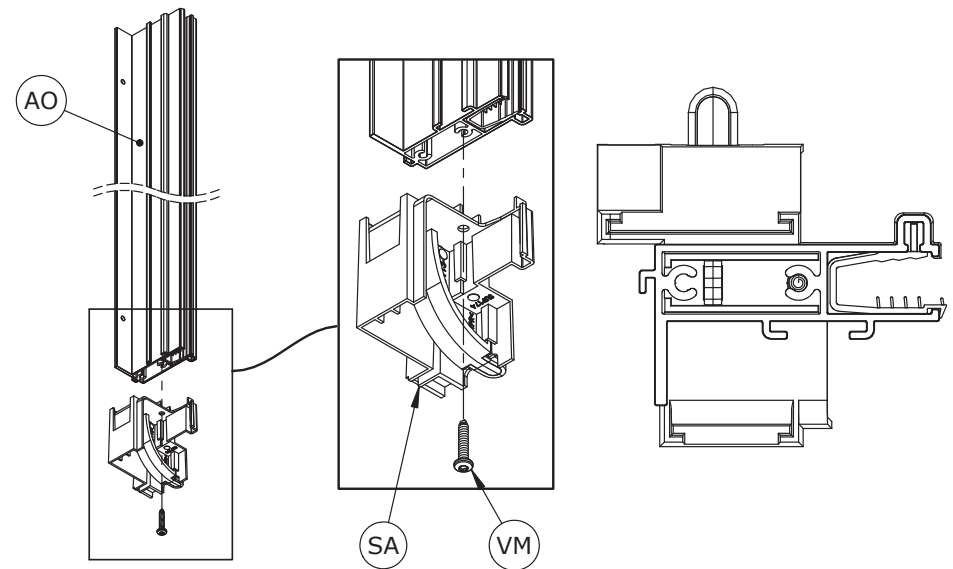

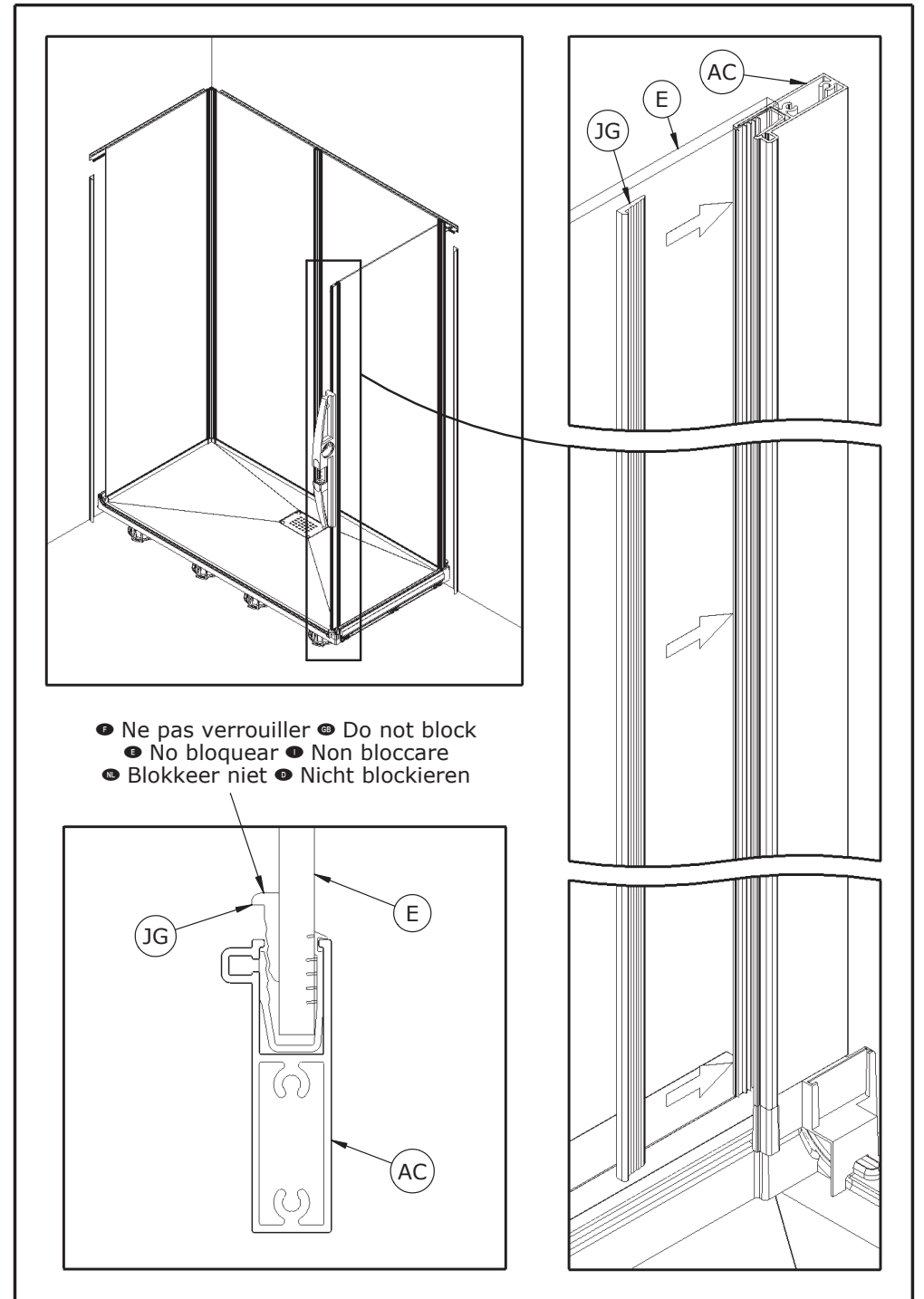
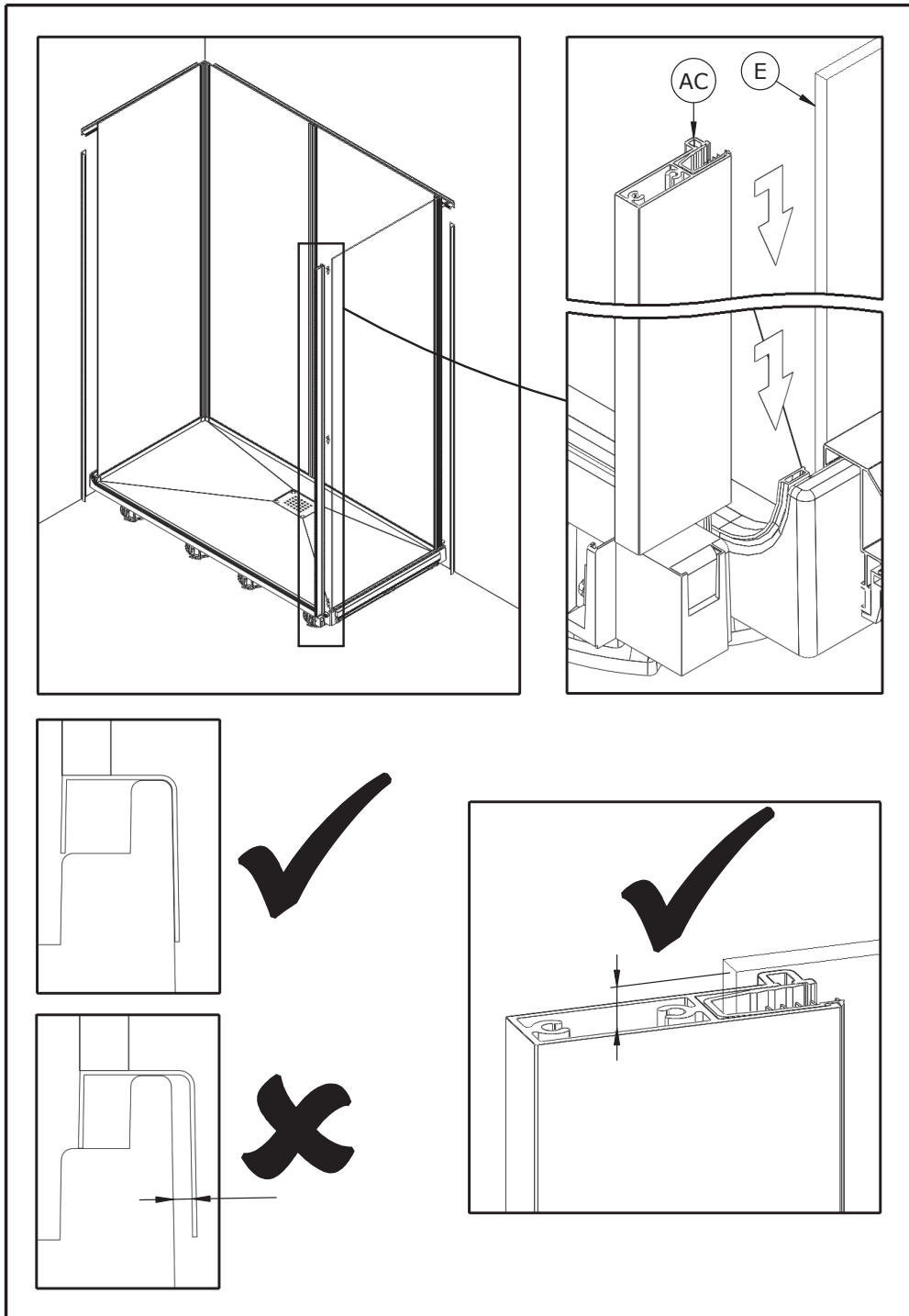

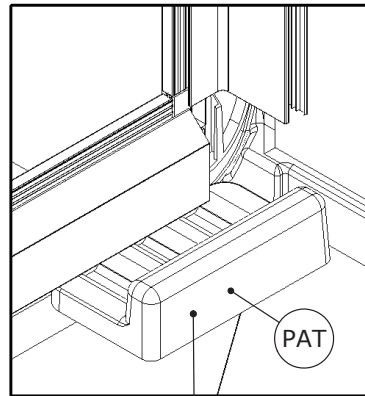
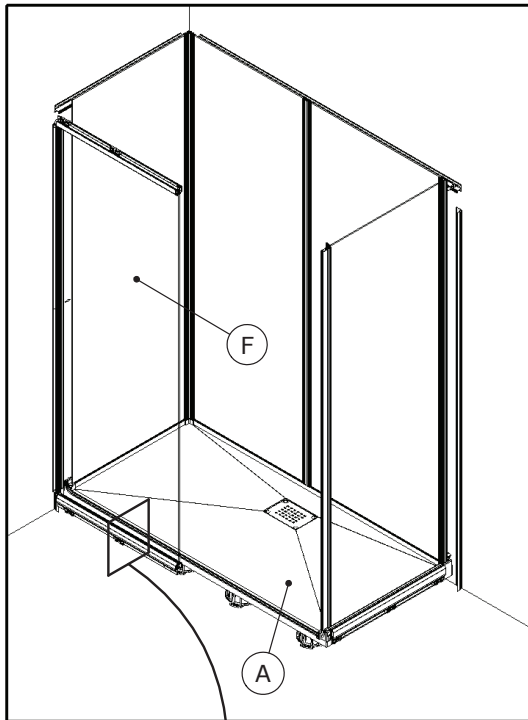

- Retirer ● Remove
- Quitar ● Togliere
- Verwijderen
- Entfernen

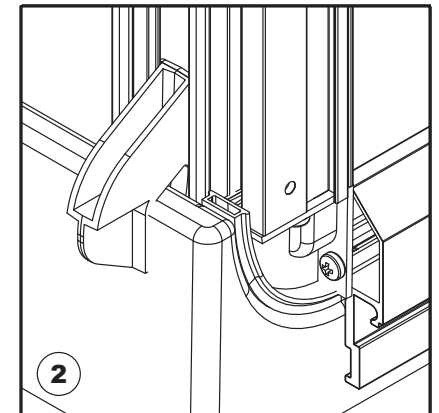
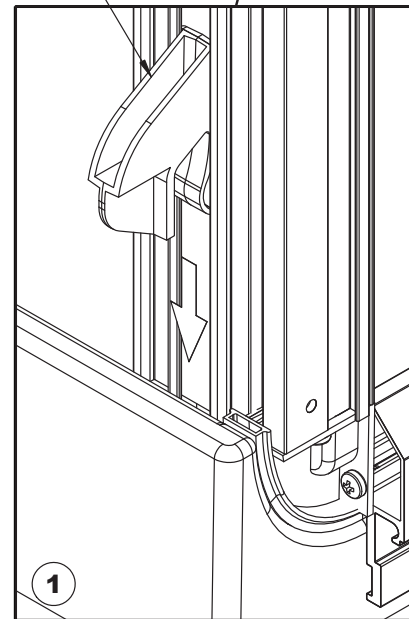
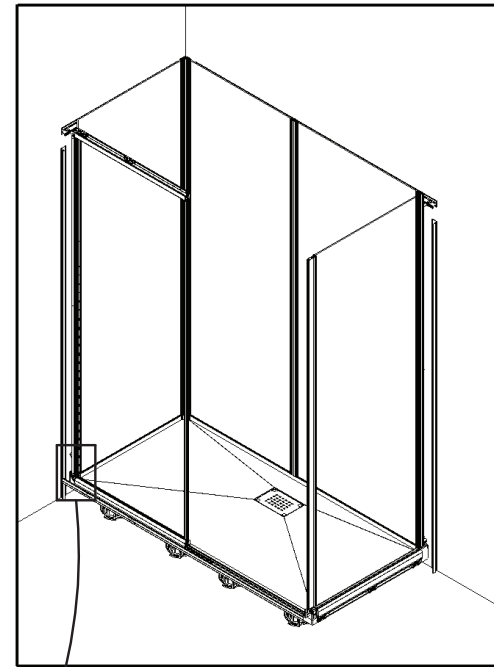
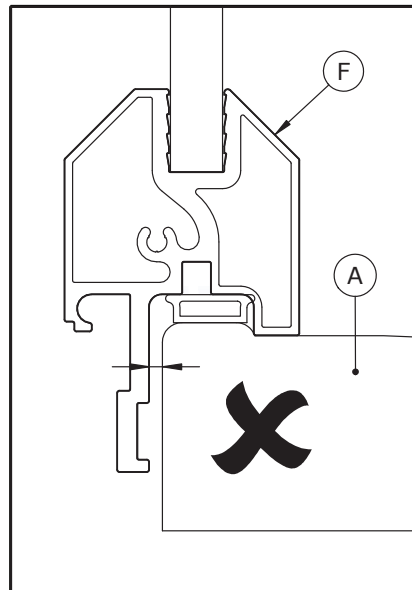
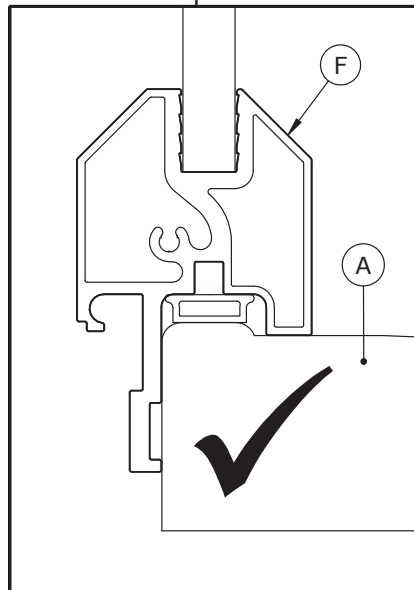

- Vue de derrière ● Back view
- Vista trasera ● Vista posteriore
- Zicht naar achteren ● Rückansicht

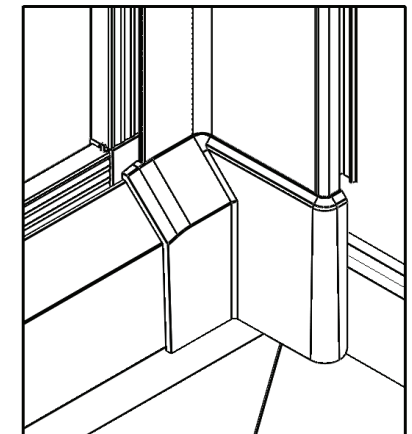
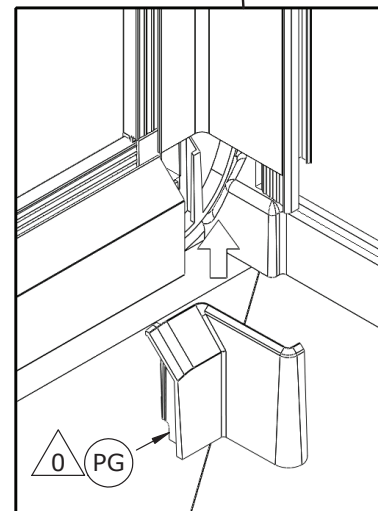
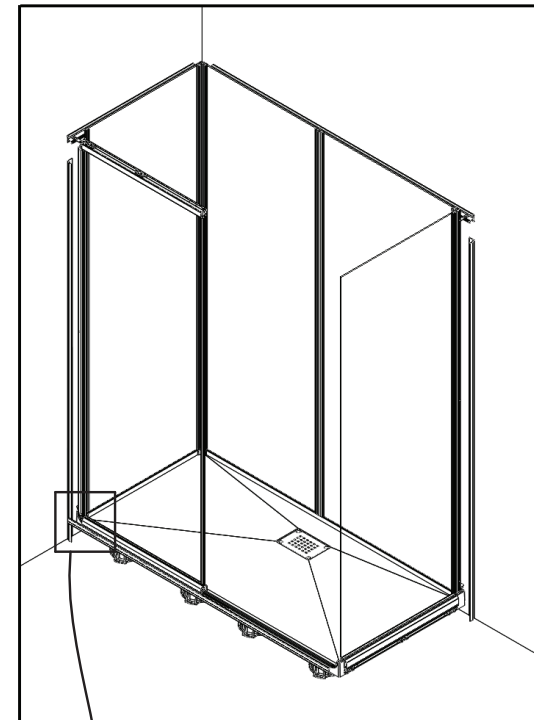
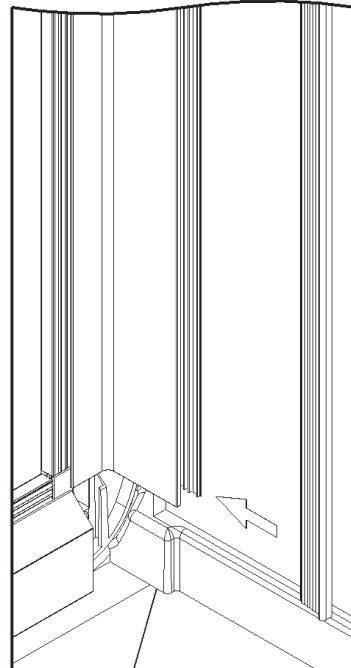
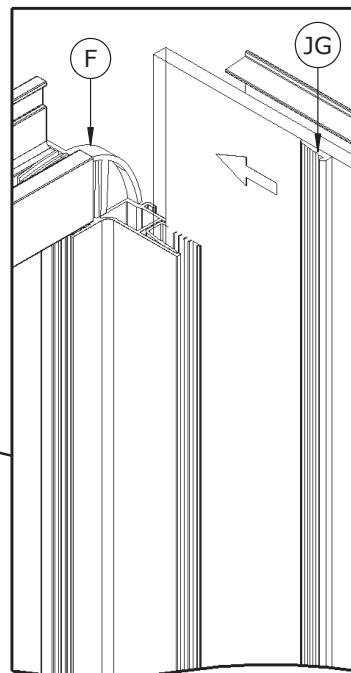
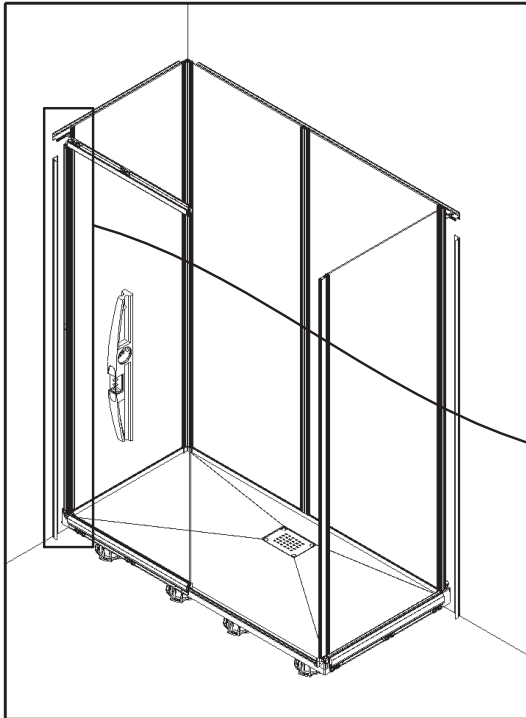

- Ne pas verrouiller • Do not block
- No bloquear • Non bloccare
- Blokkeer niet • Nicht blockieren

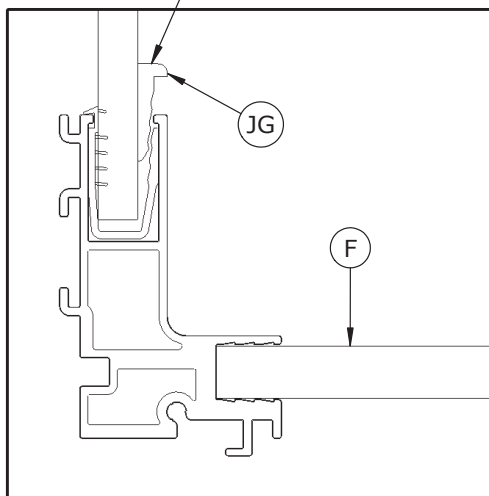

- Intérieur douche • Inside shower
- Interior ducha • Doccia interni
- Binnen douche • Innenraum der Kabine

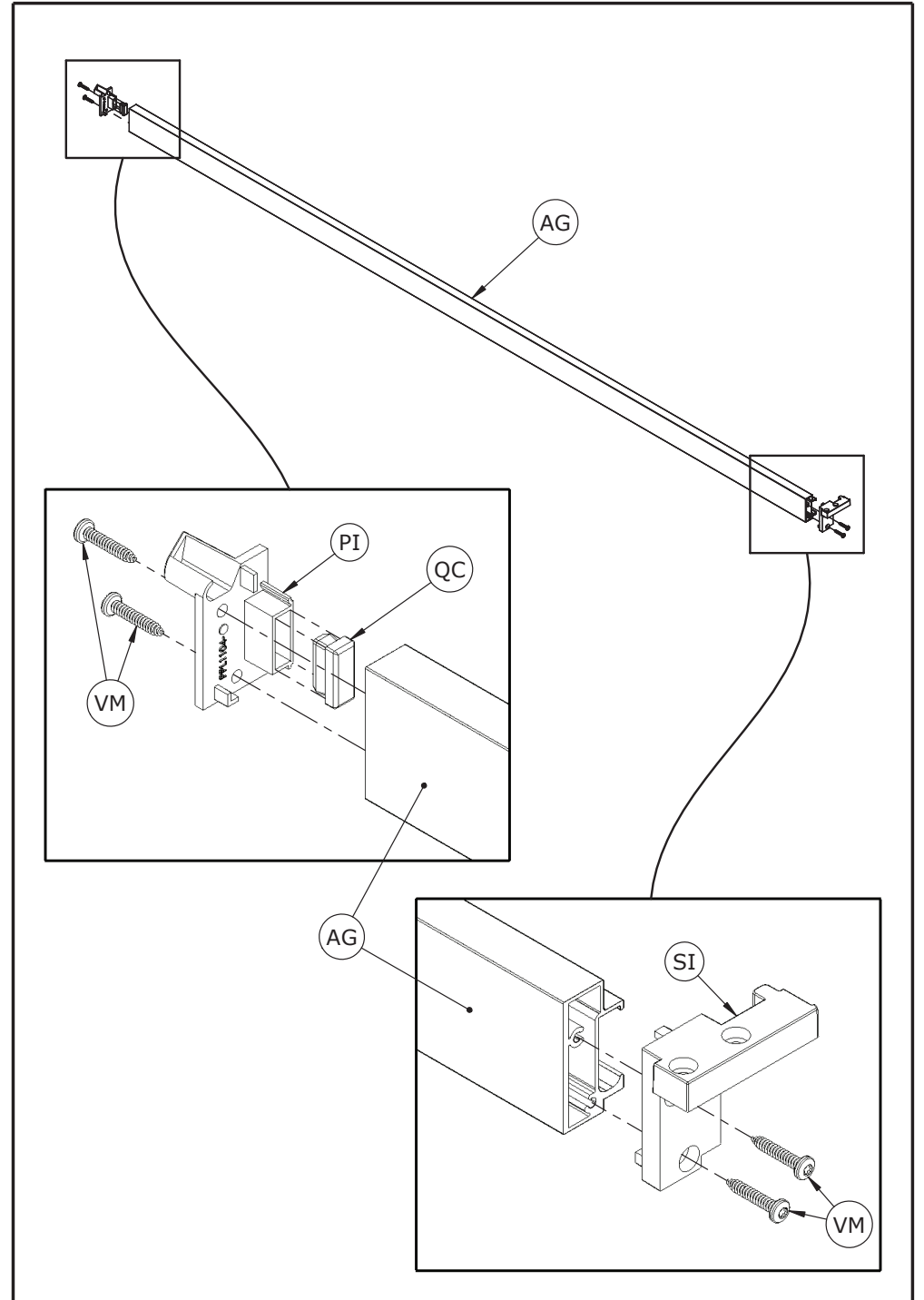
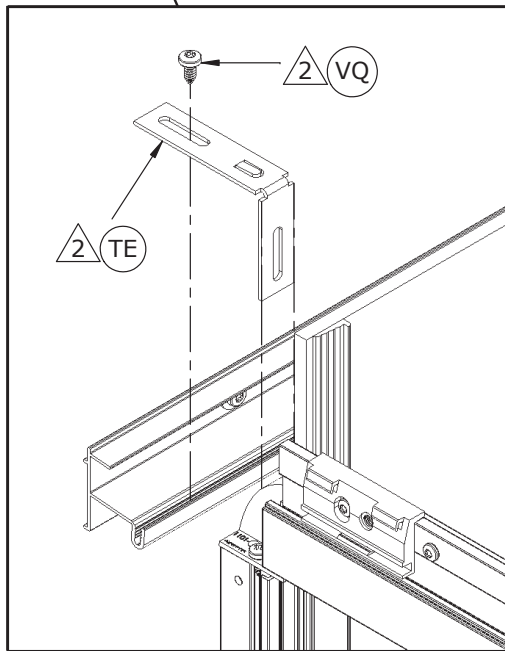
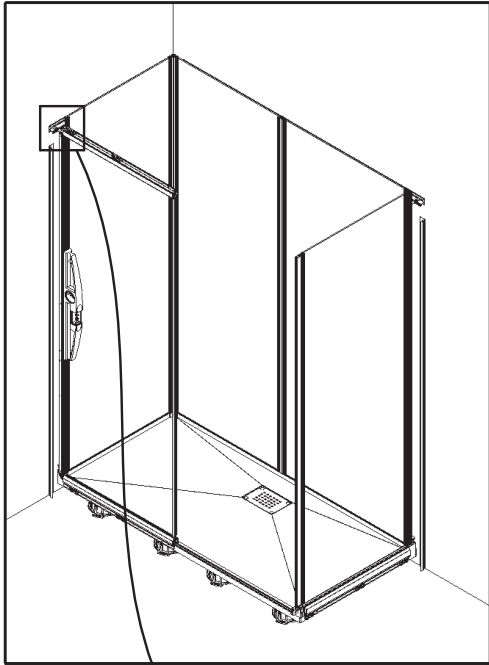

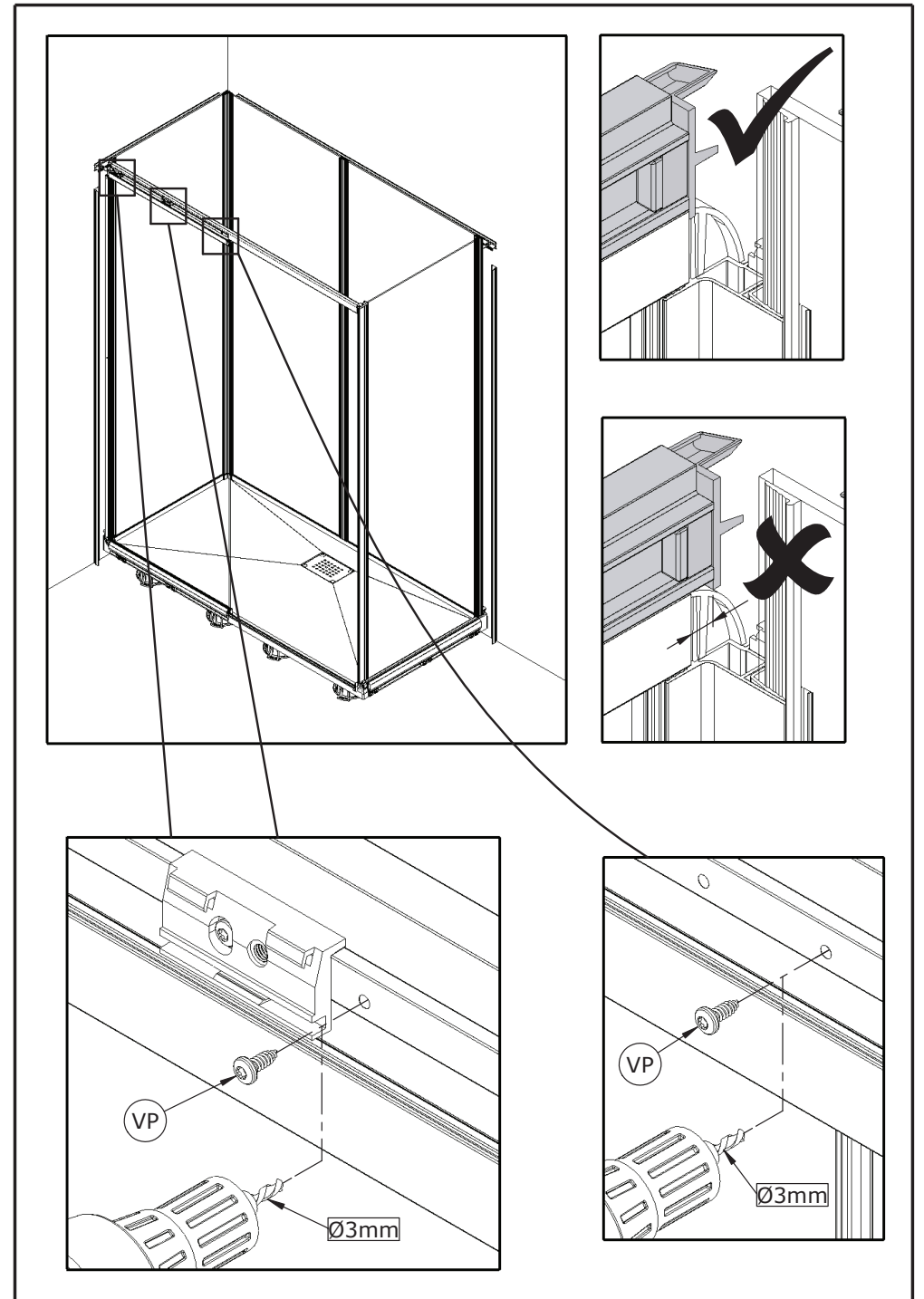
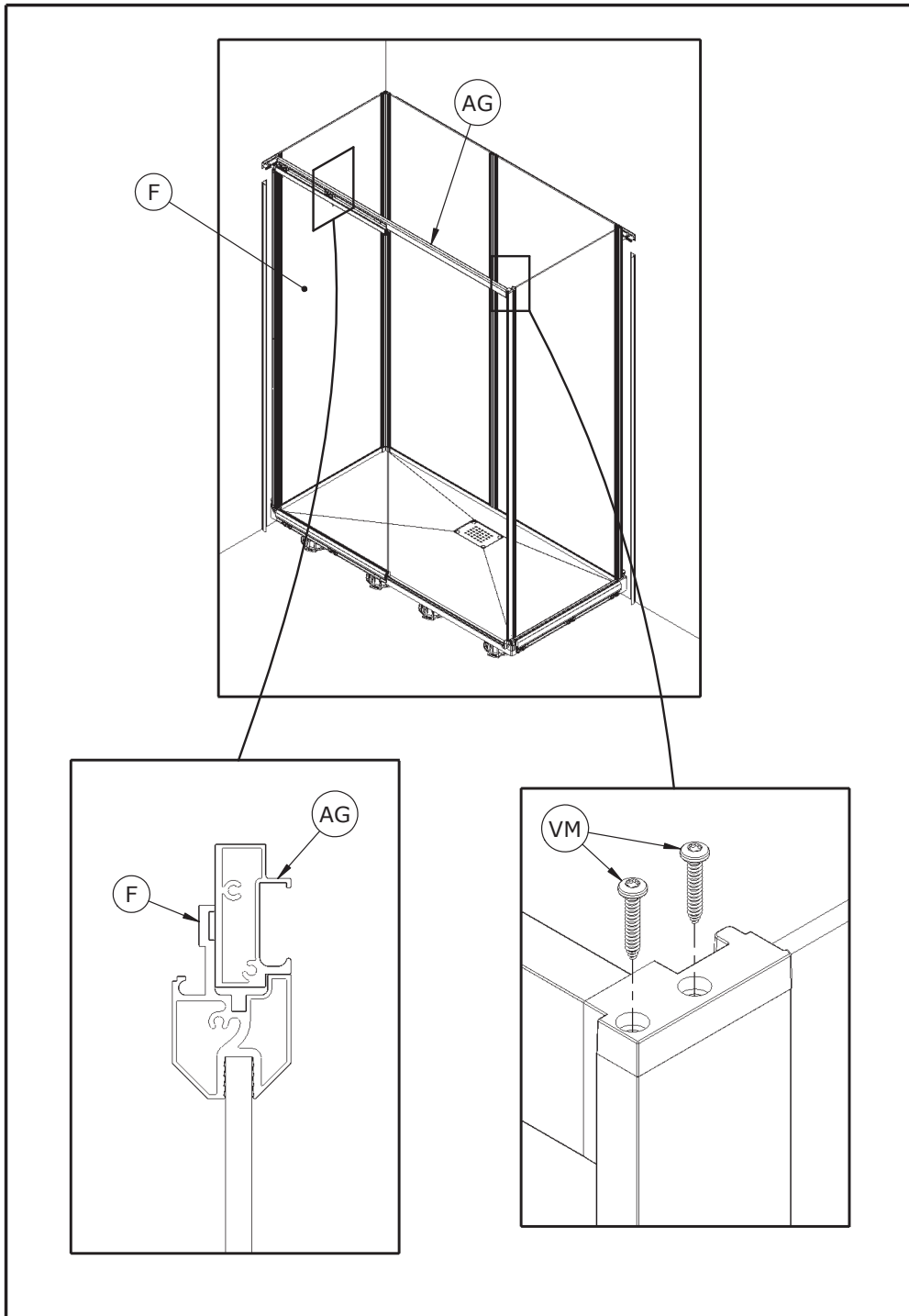

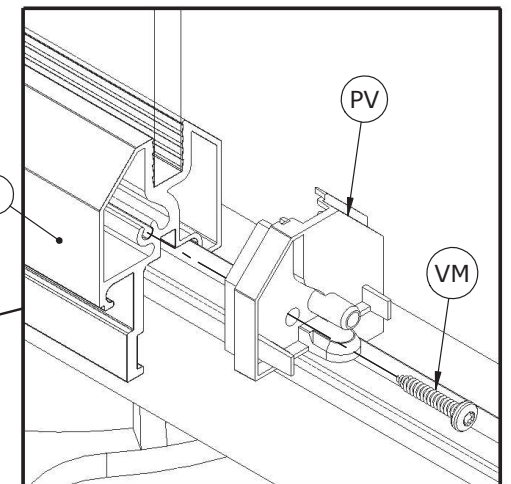
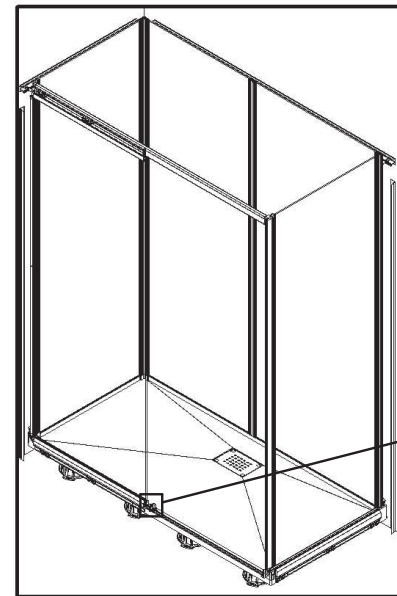
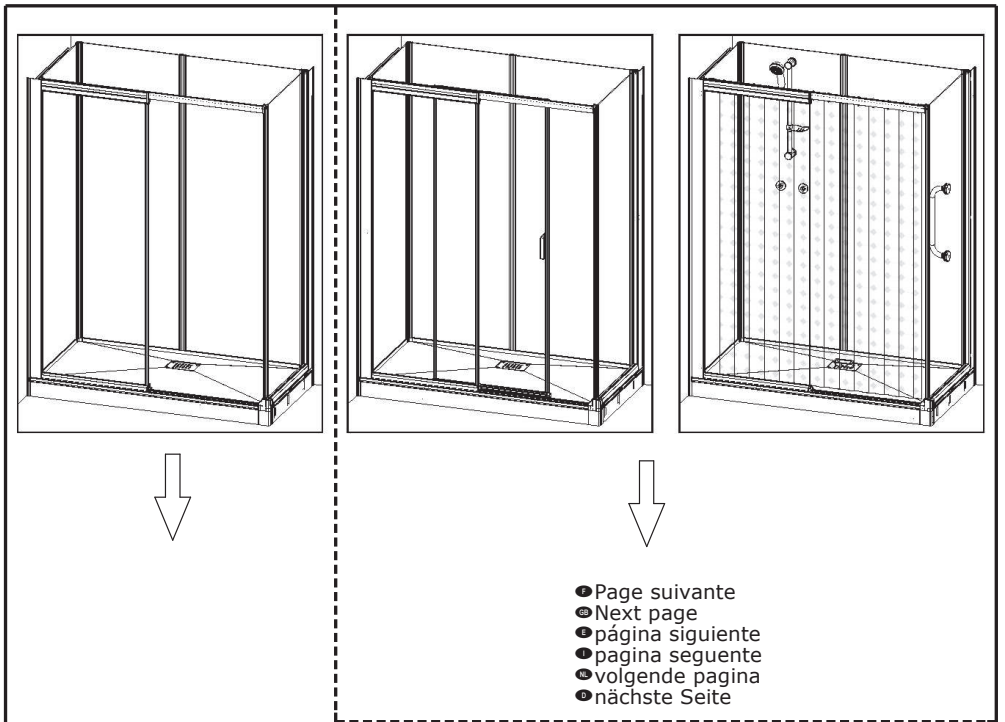
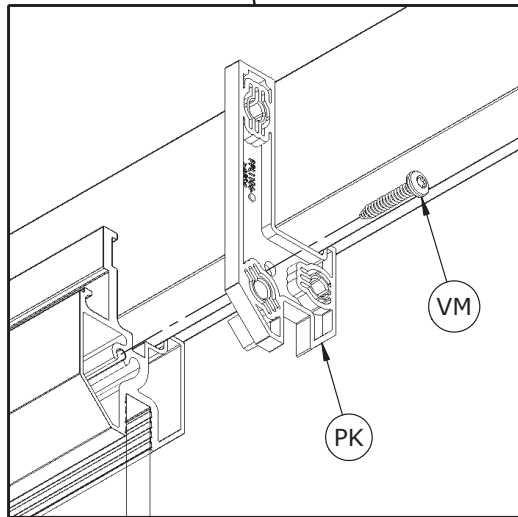
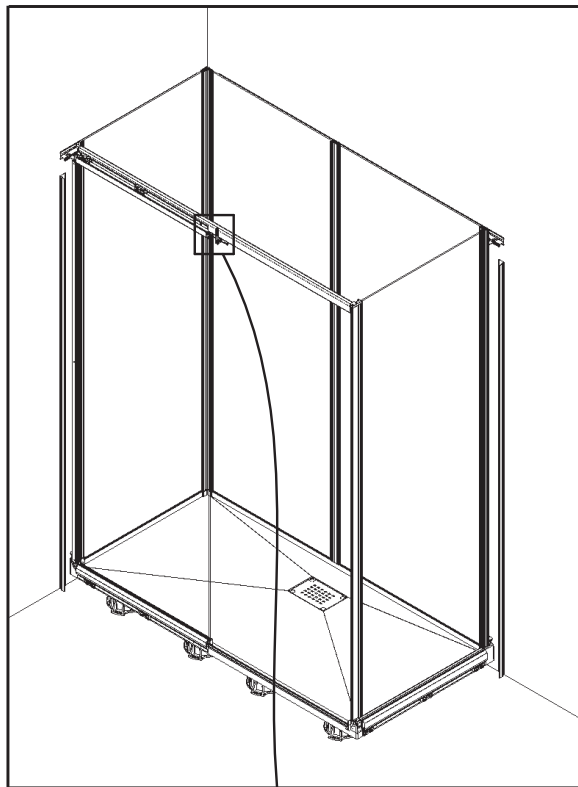

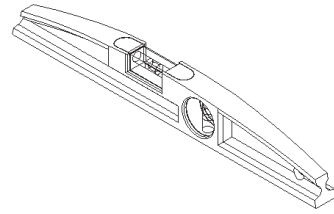
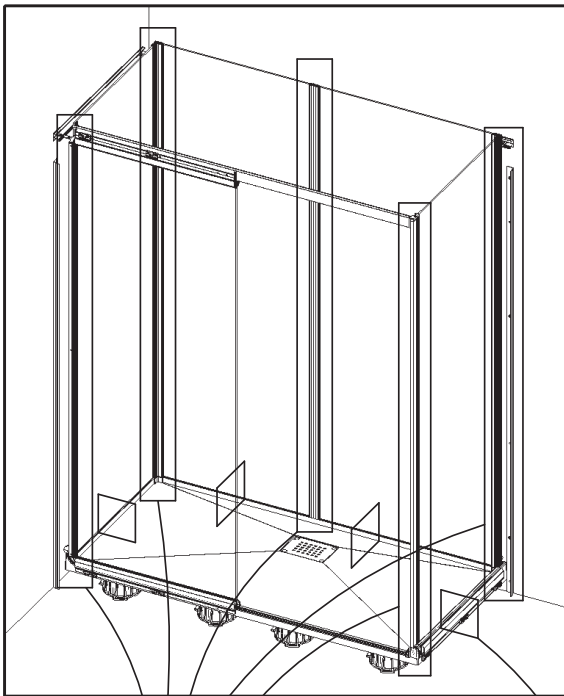

- Vérifier l'aplomb de la cabine, puis verrouiller
- Ensure level then block
- Verificar la verticalidad de la cabina, y bloquear
- Assicurarsi che la doccia è di livello, e bloccare
- Controleer of de douhecabine goed recht staat, en blokkeer
- Prüfen, ob die Kabine lotrecht steht, anschließend blockieren

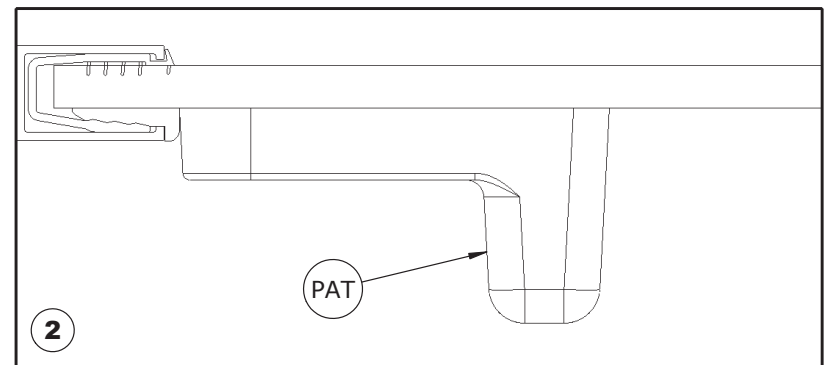
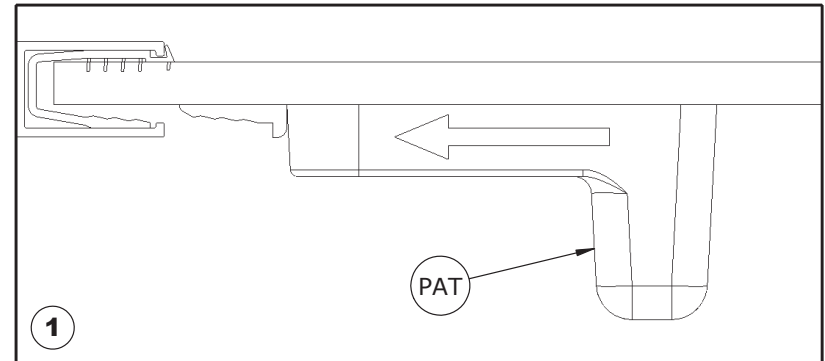
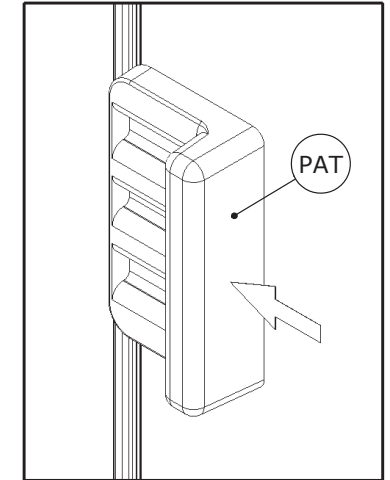
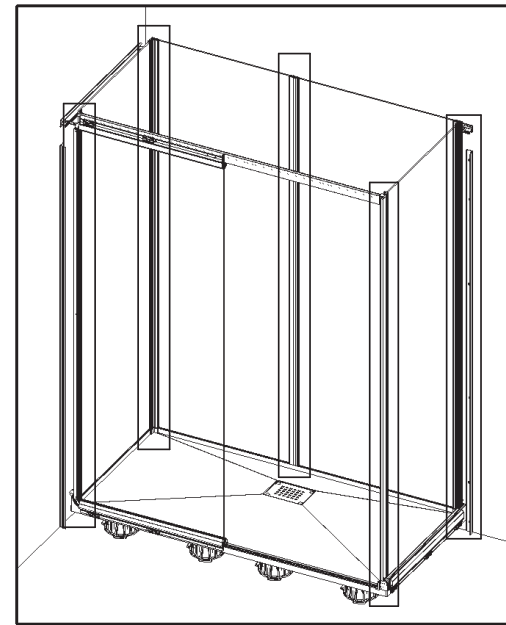
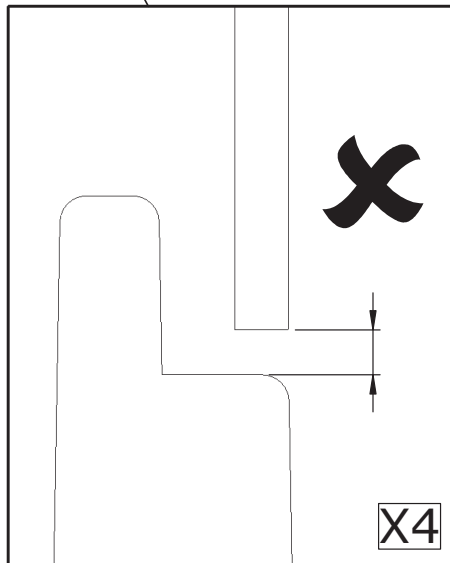
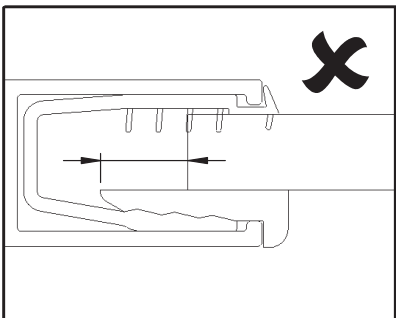
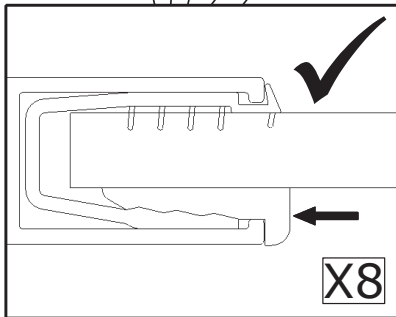

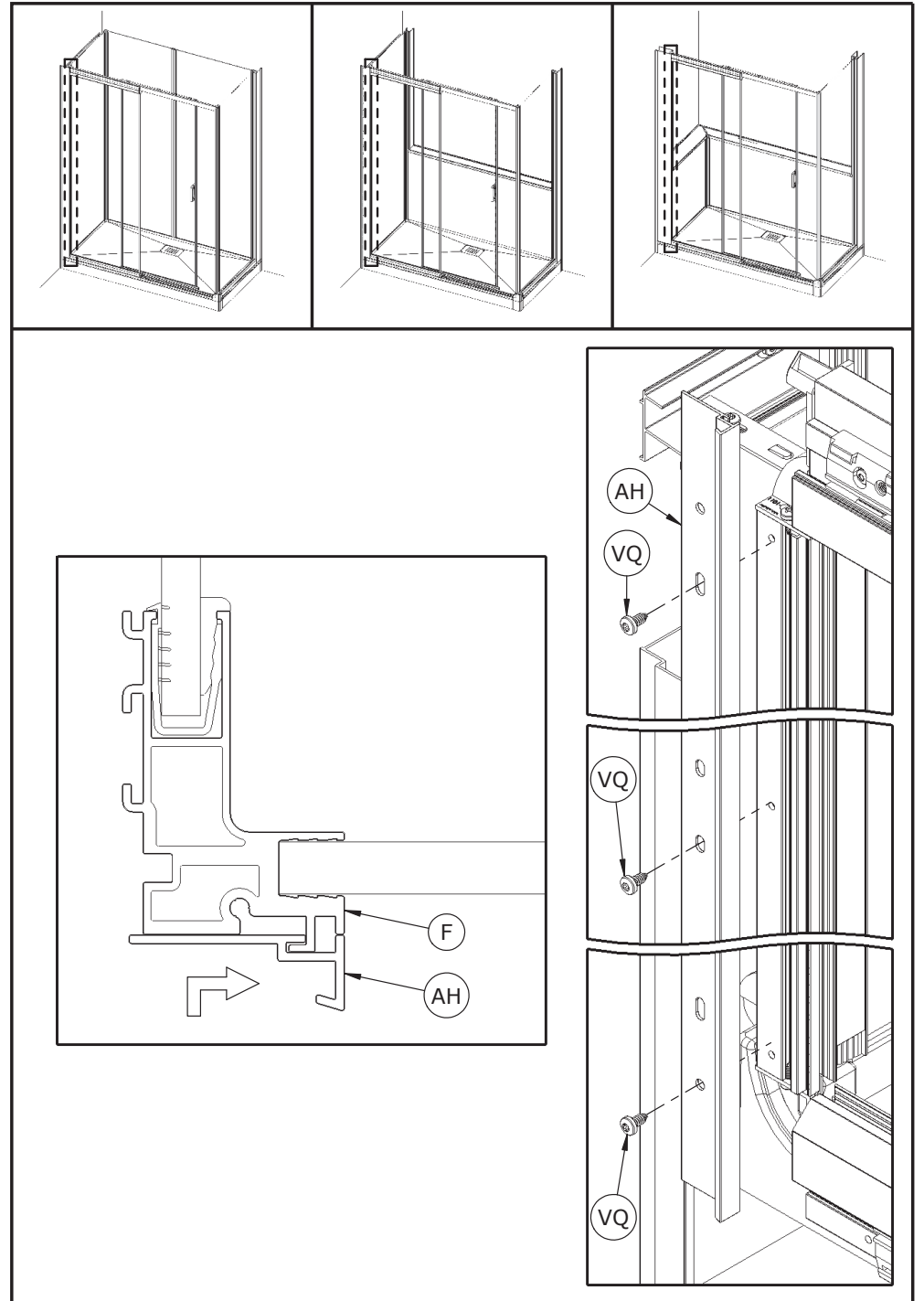
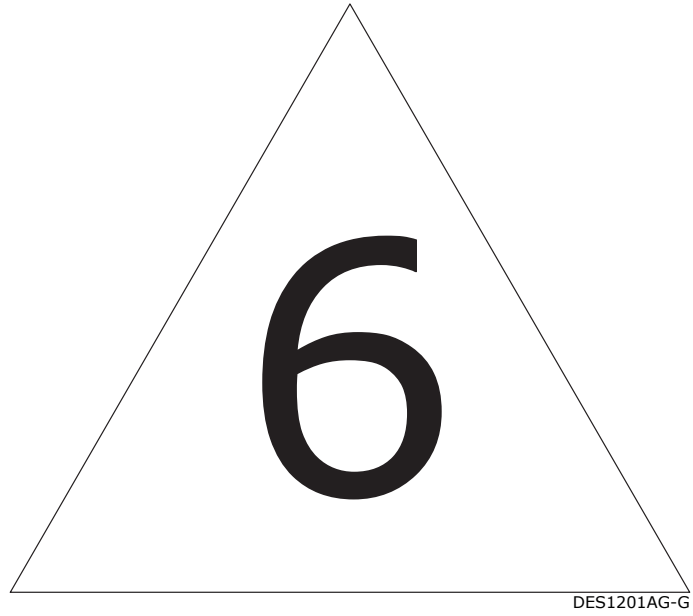

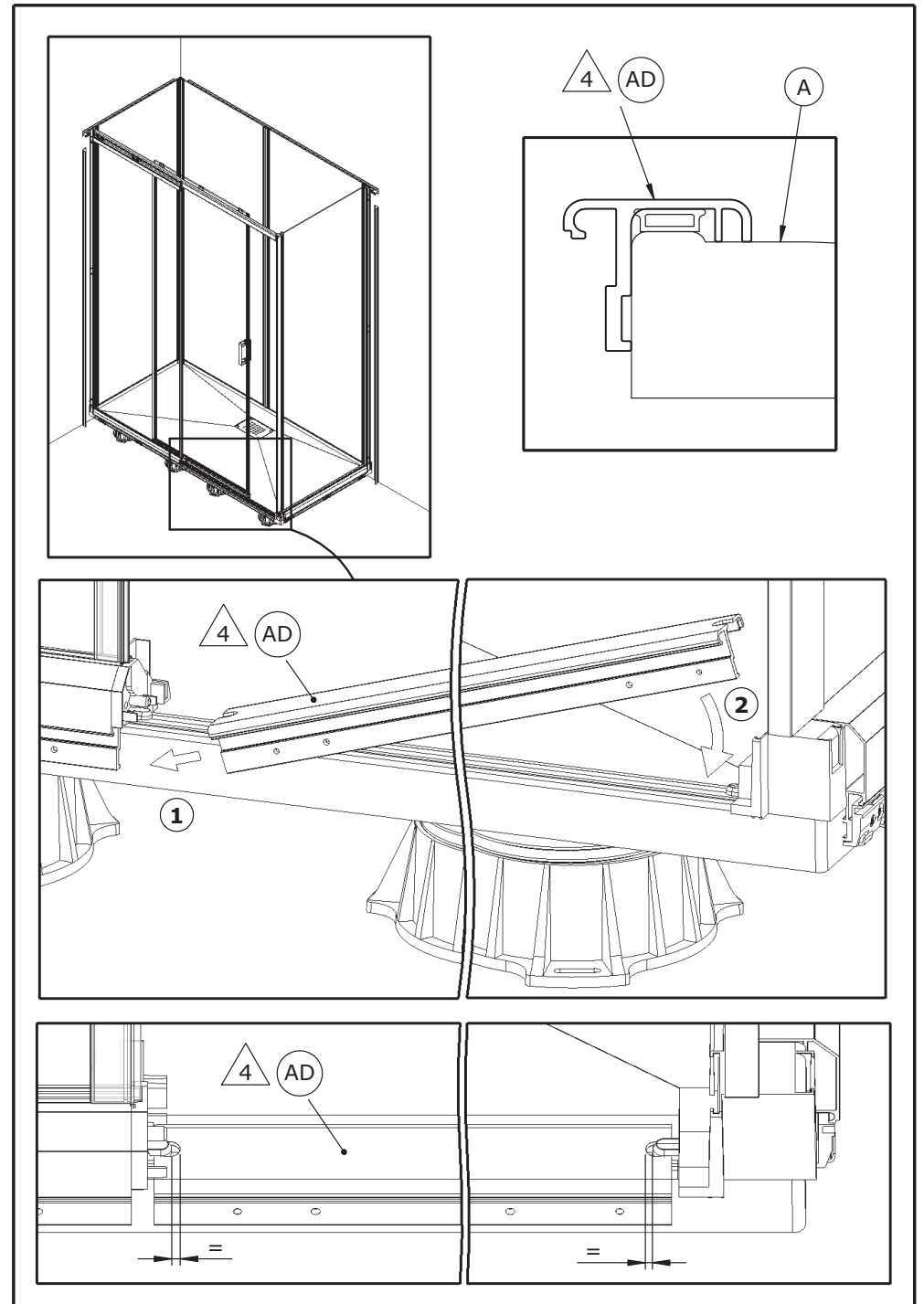
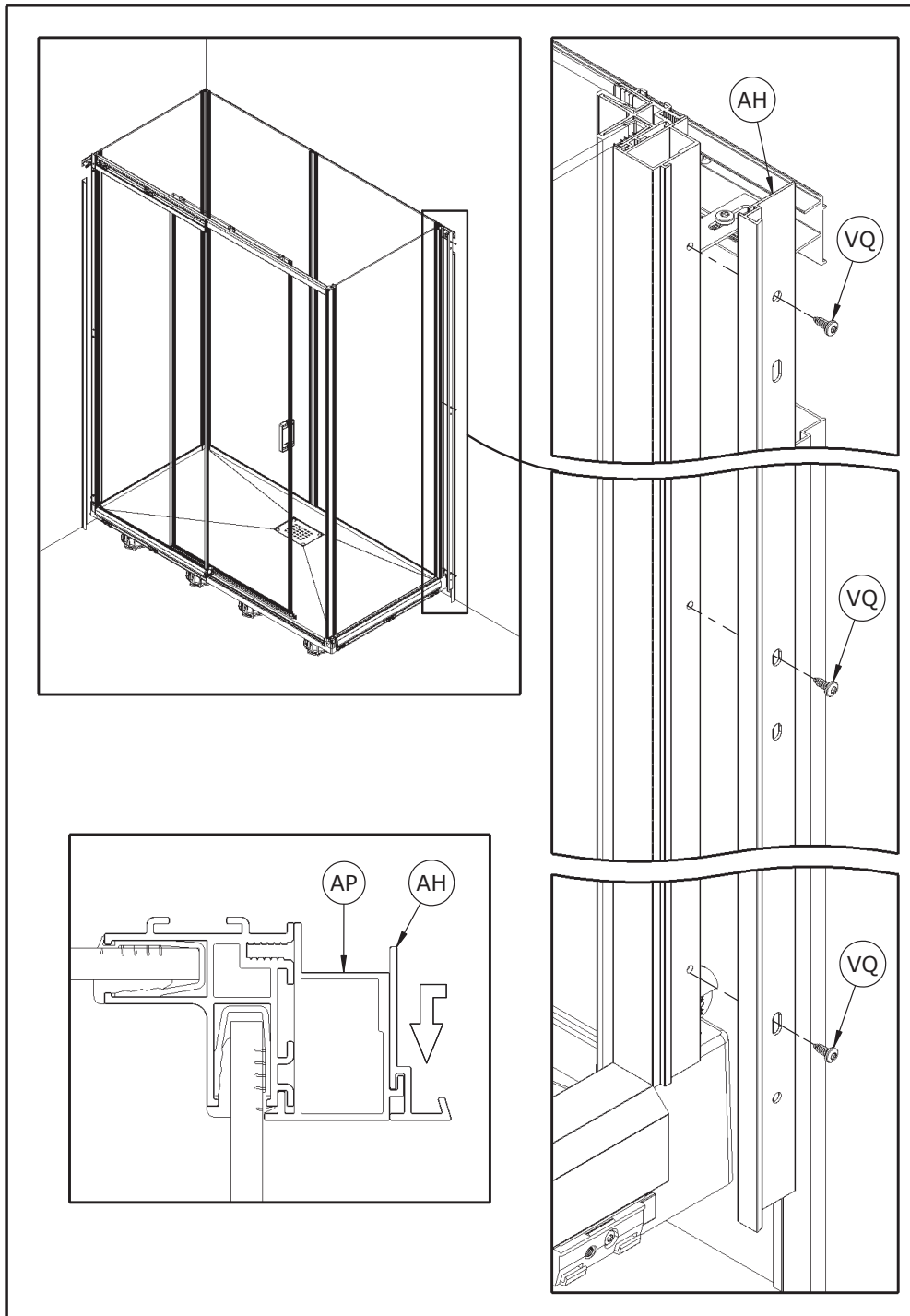

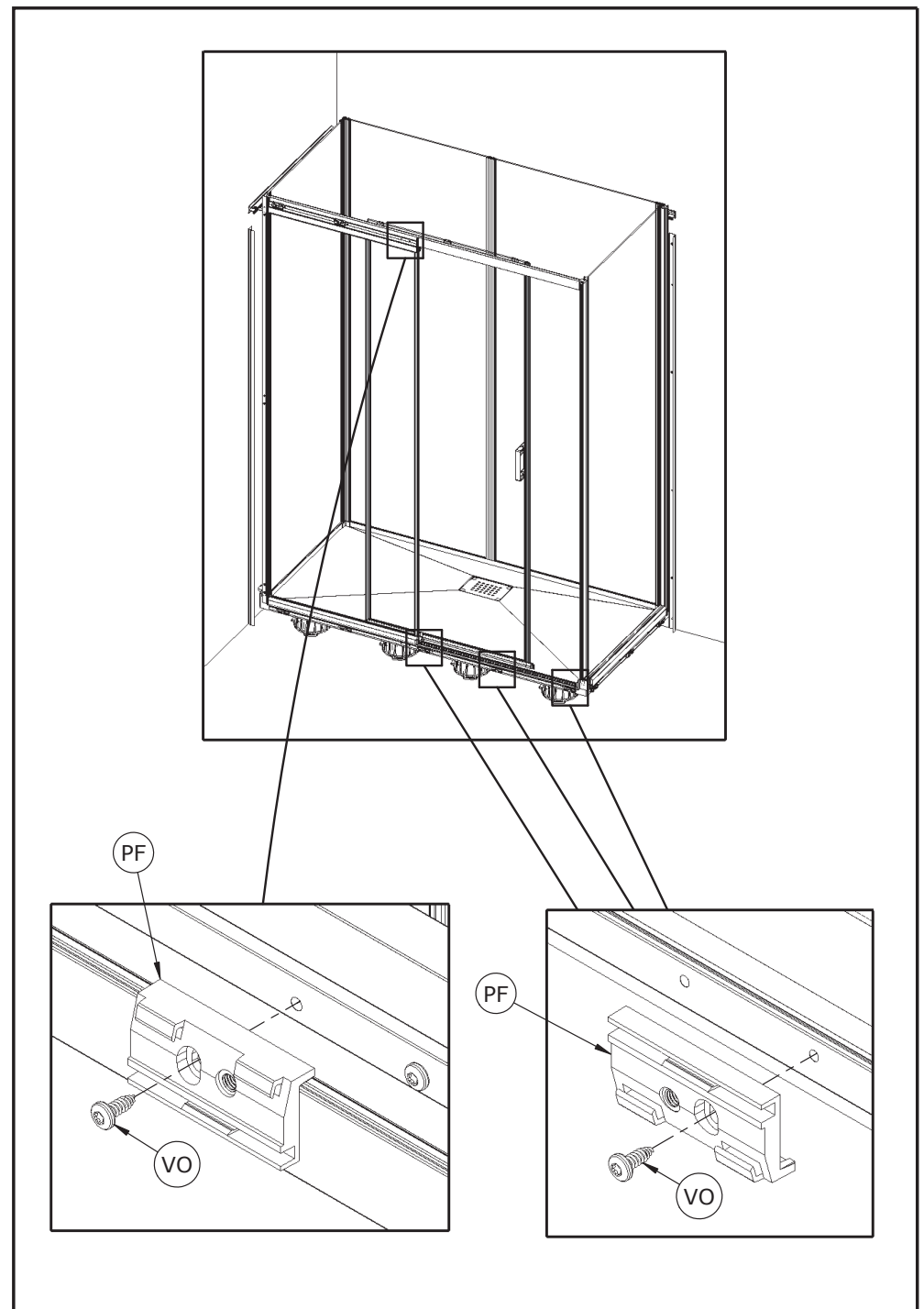
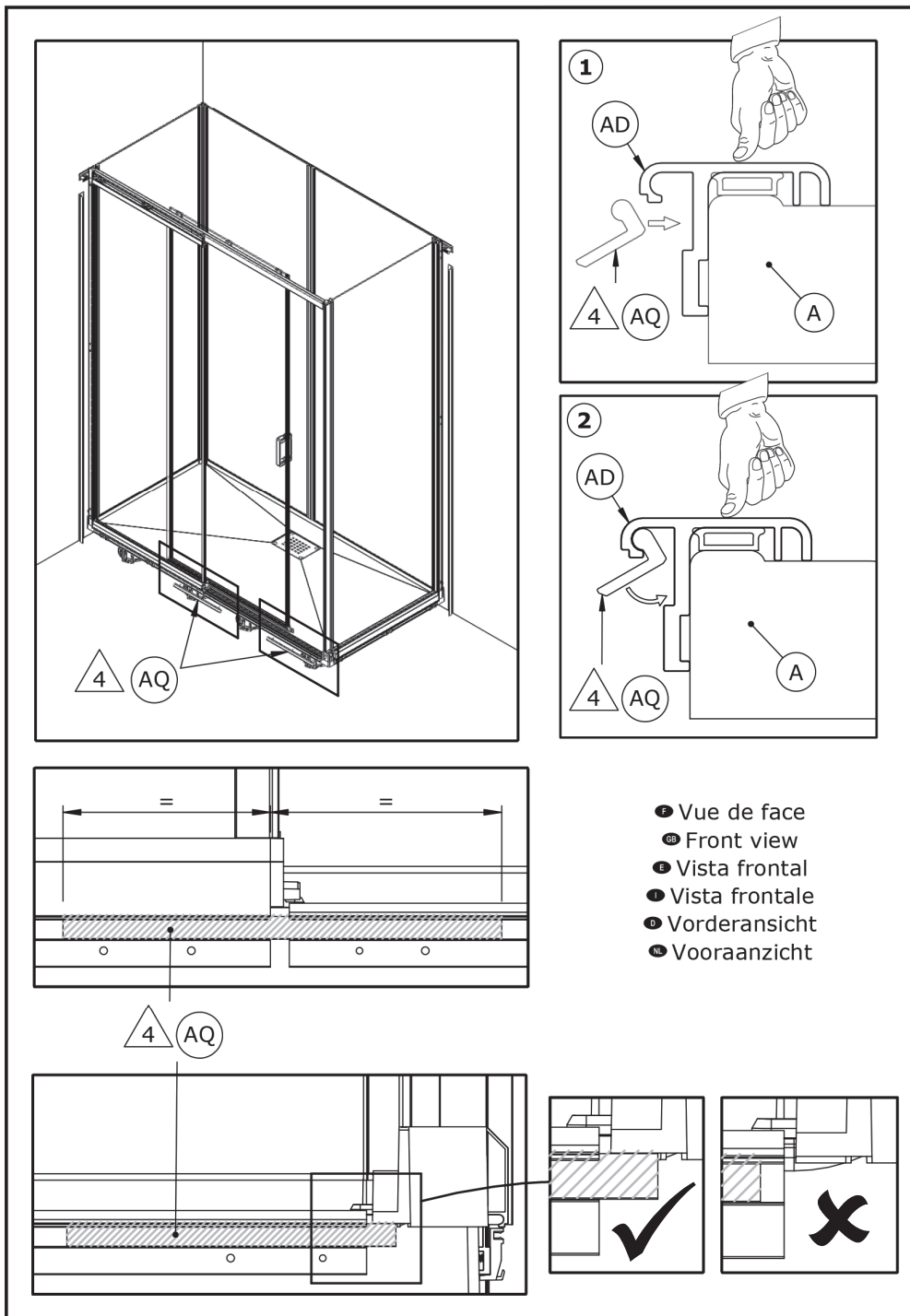

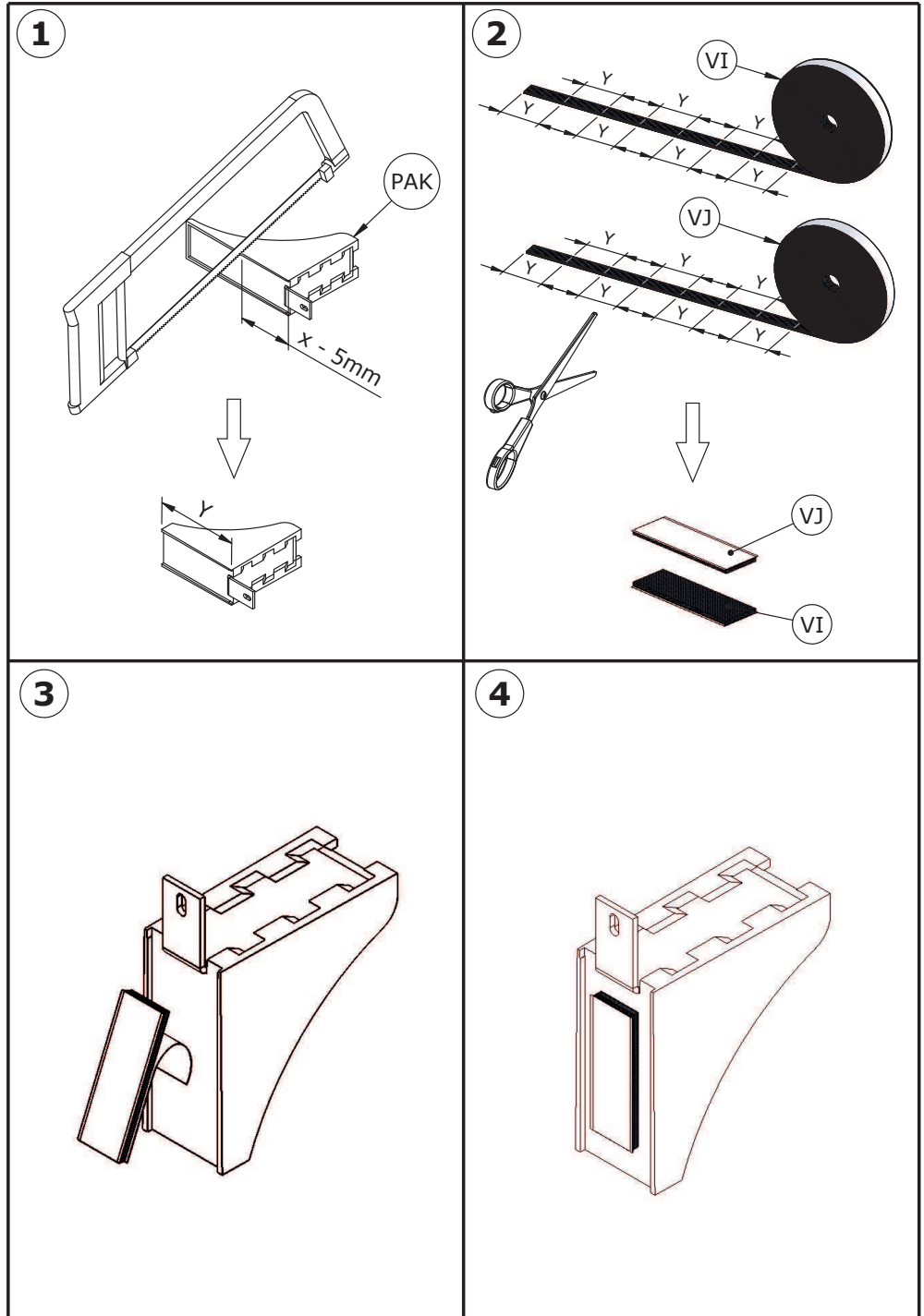
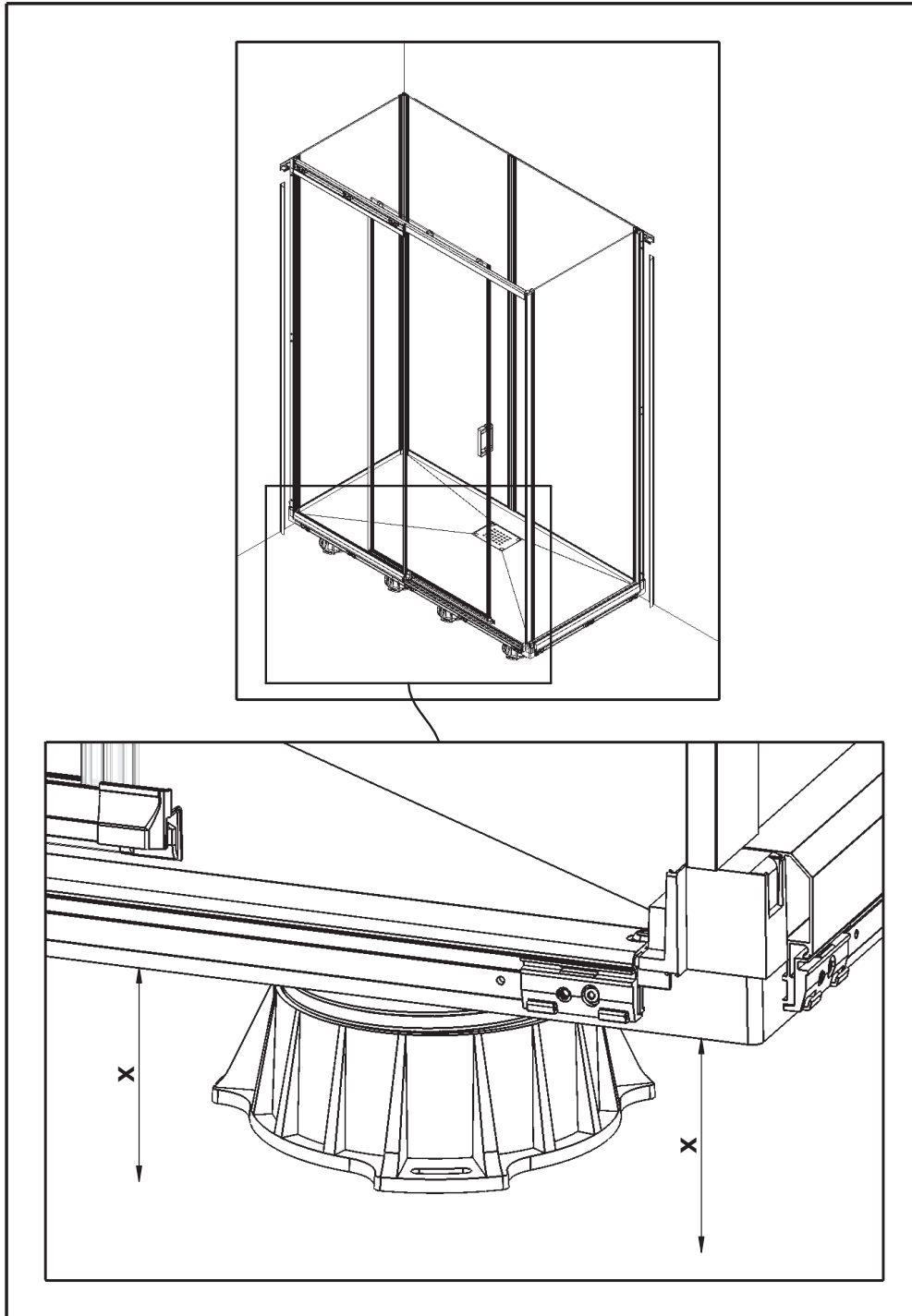

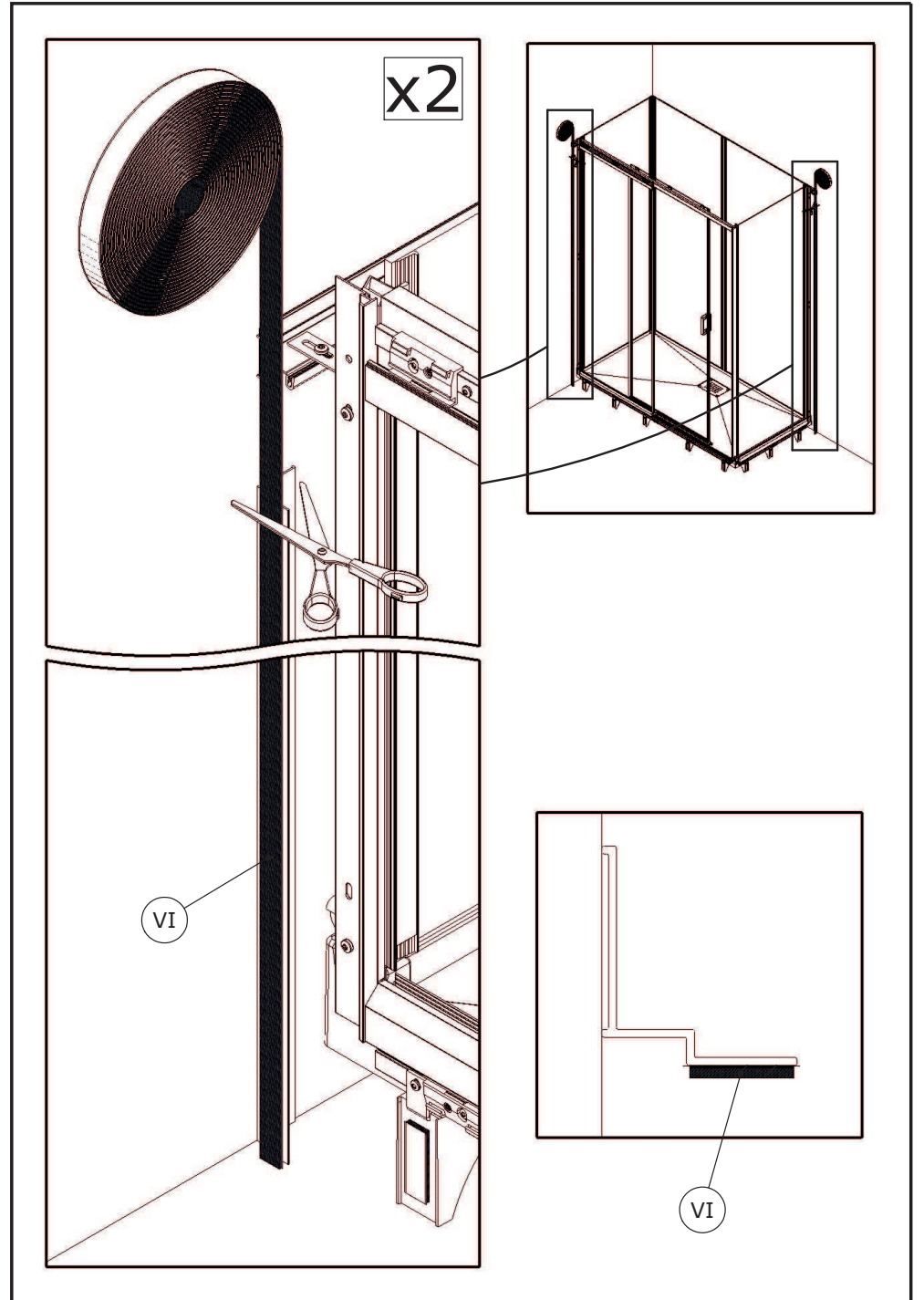
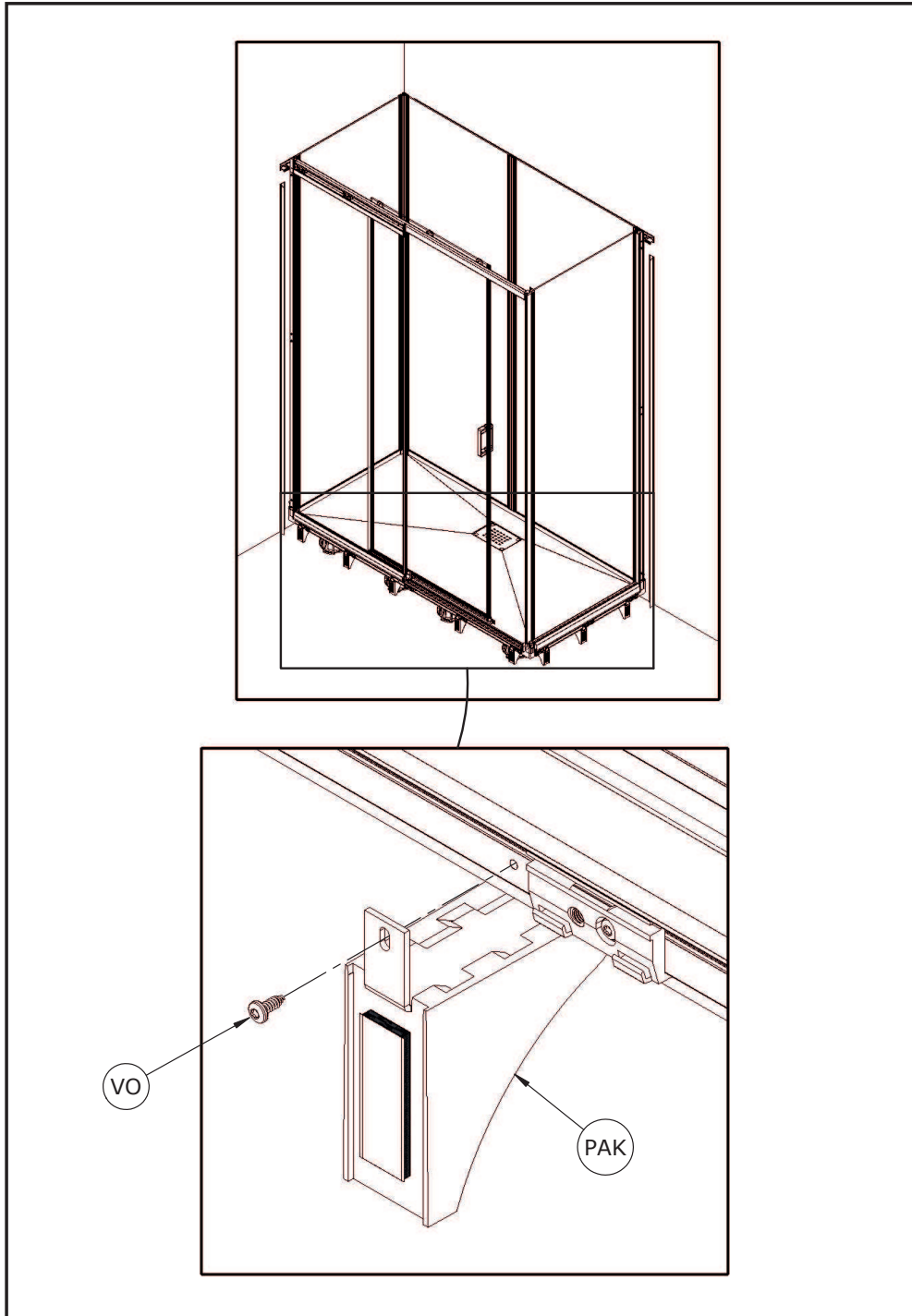

- Retirer l'adhésif
- Remove adhesive
- Quitar el adhesivo
- Rimuovere il adesivo
- Lijm verwijderen
- Klebstoff entfernen

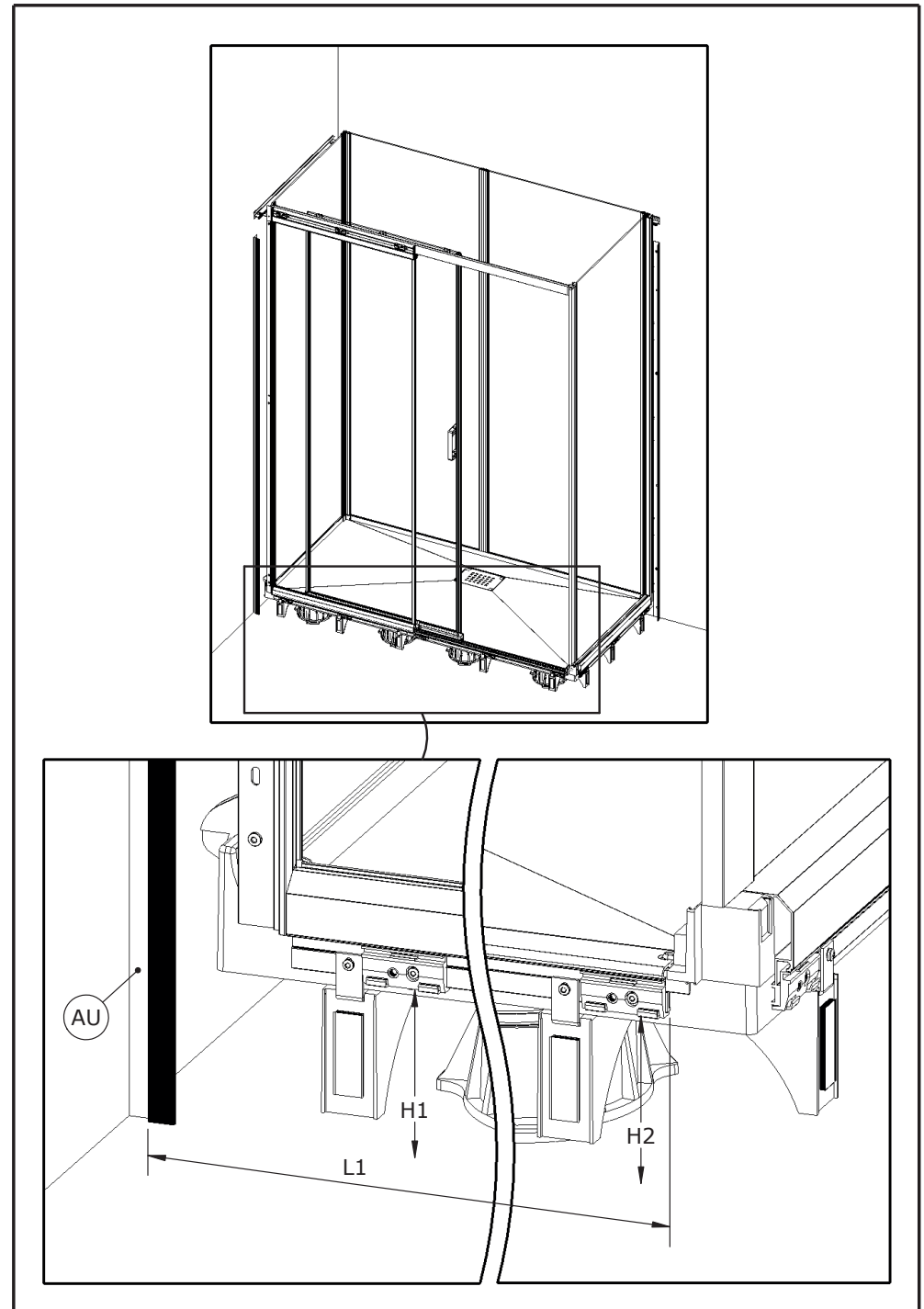
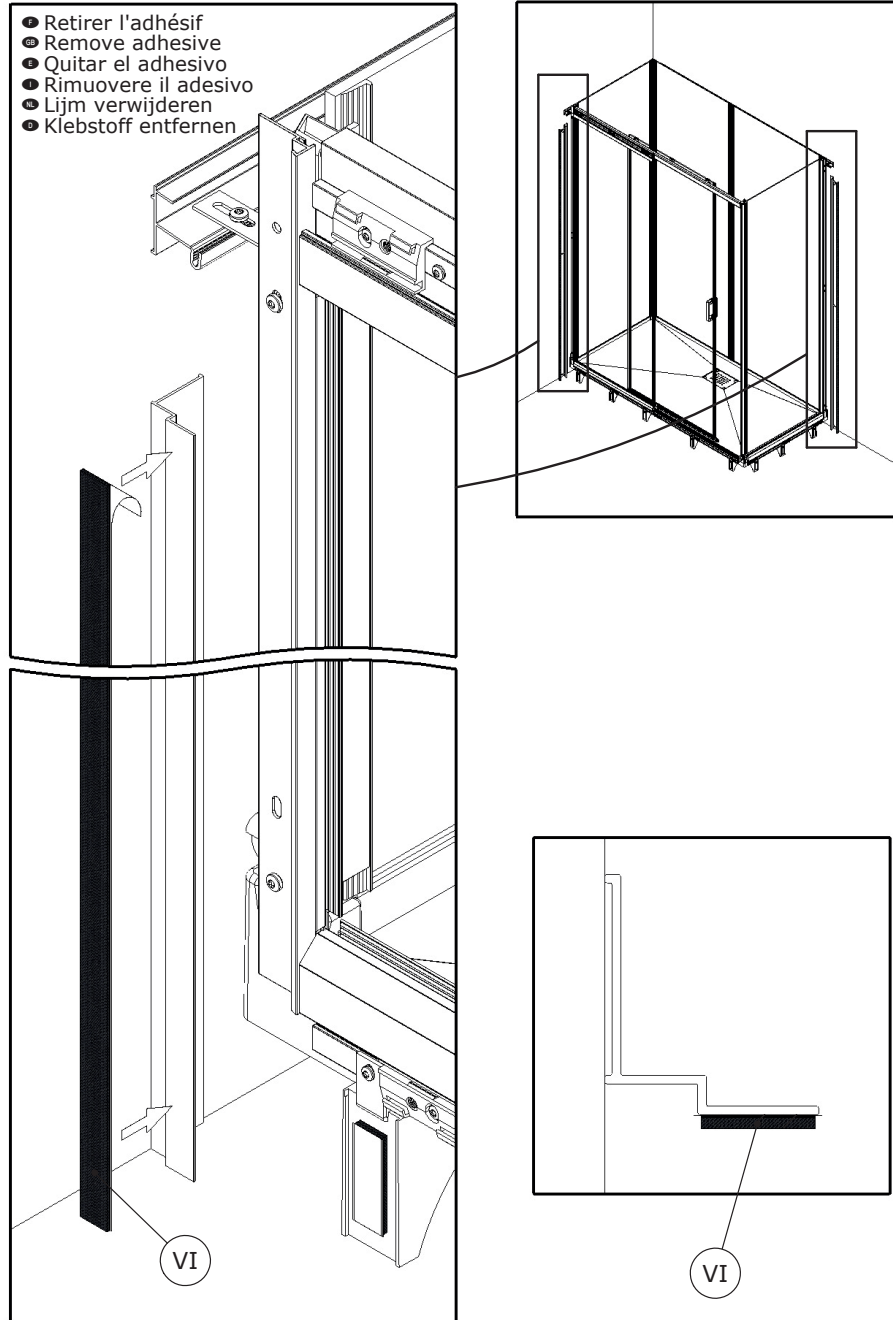

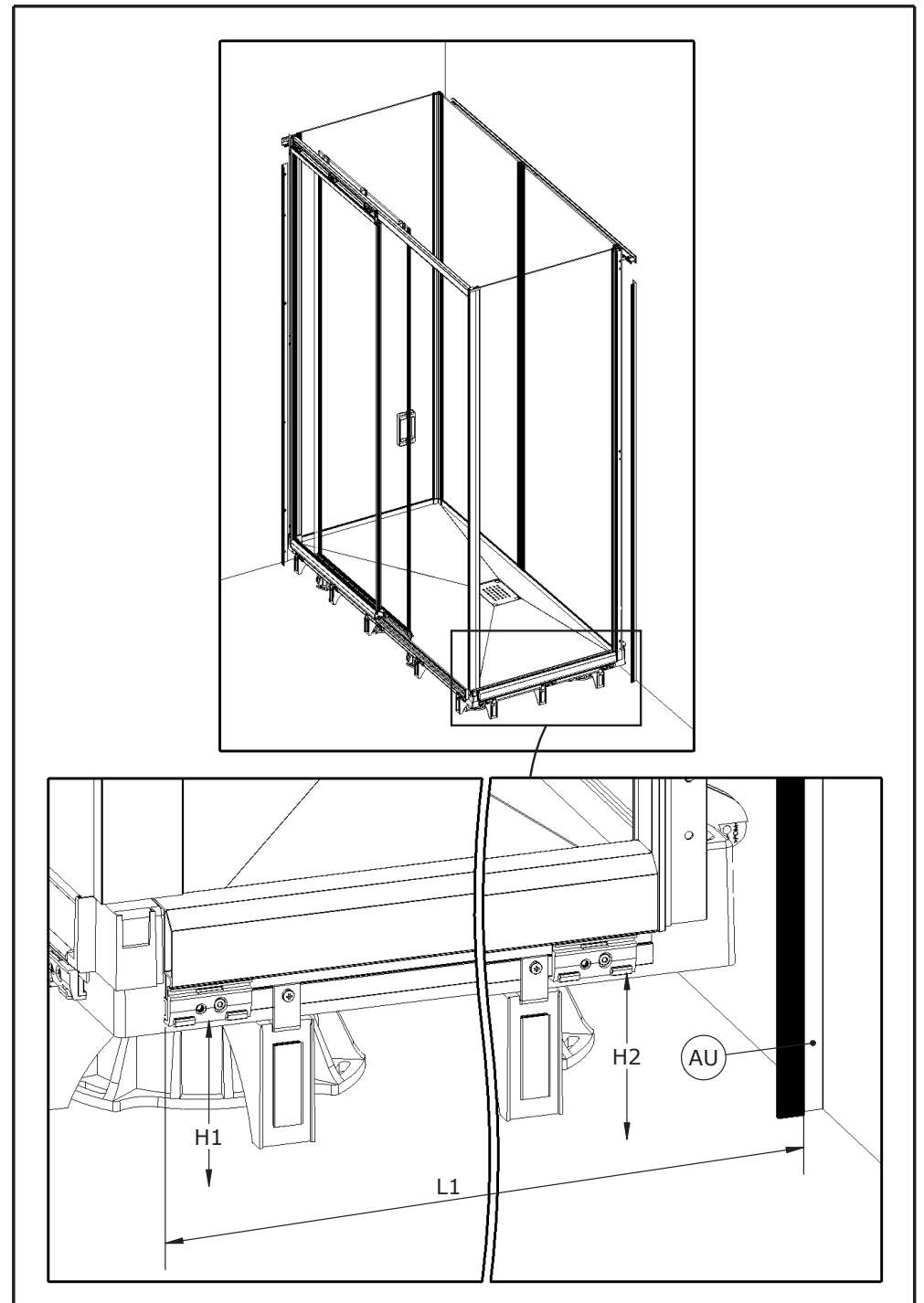
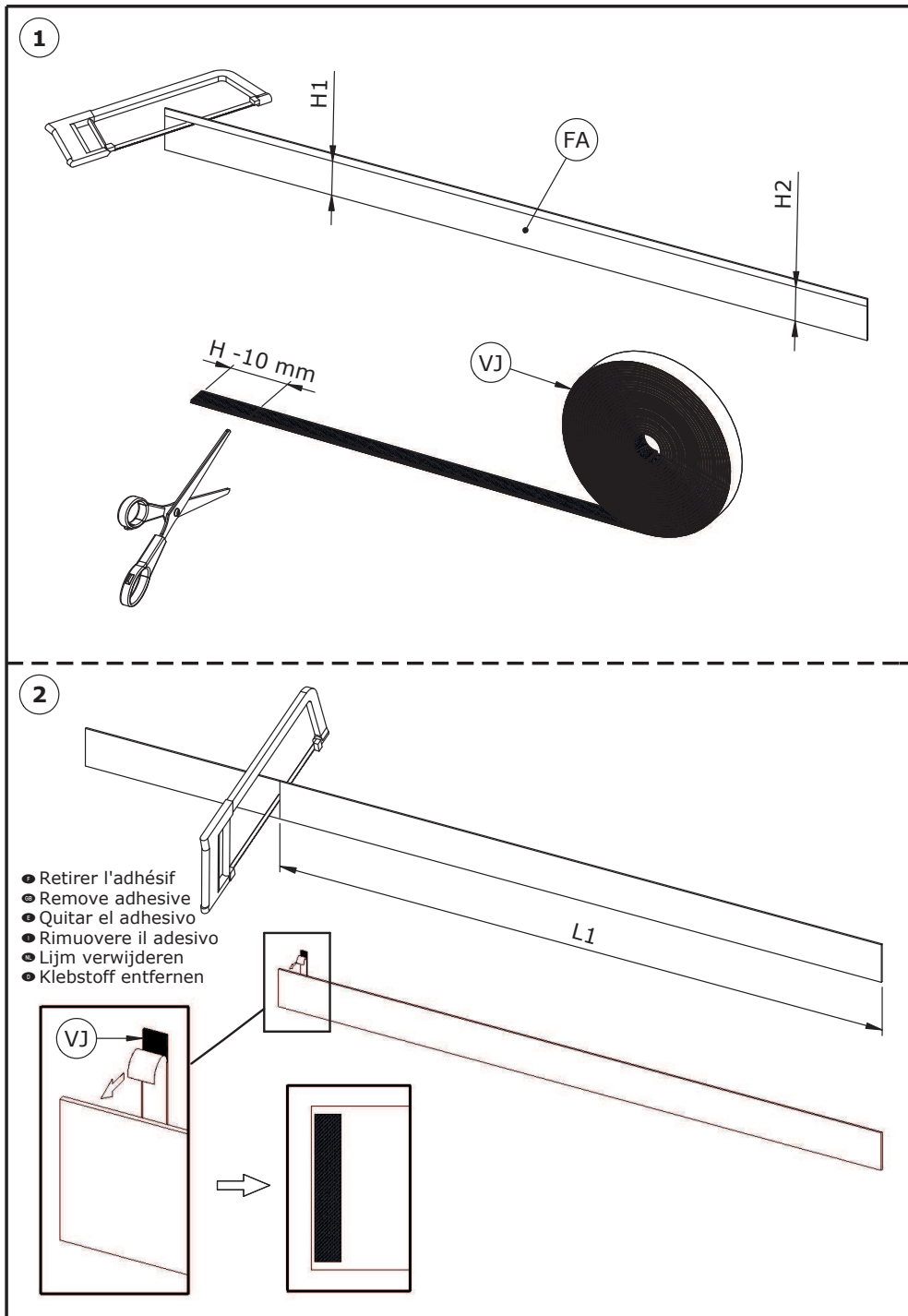

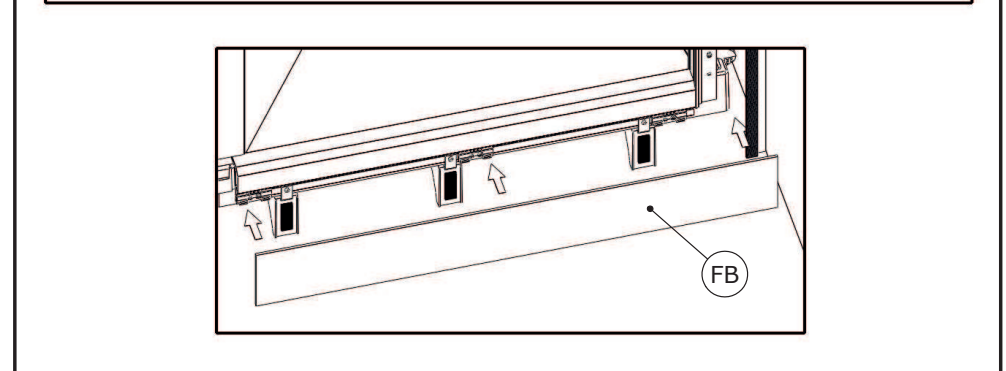
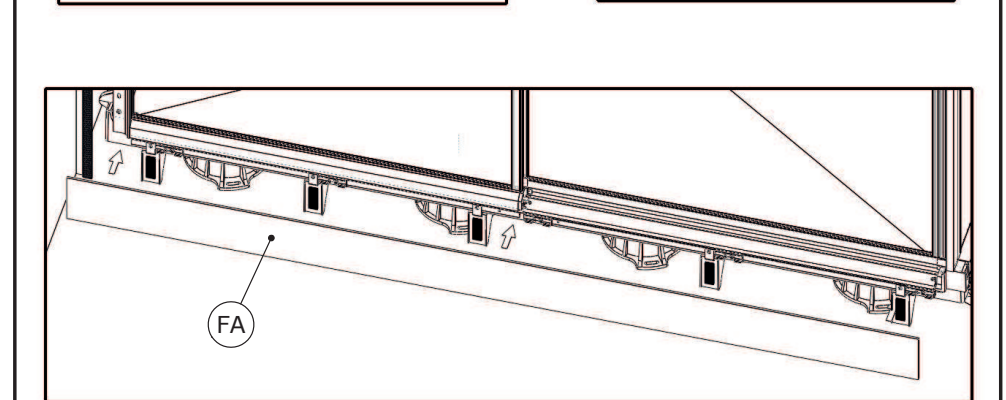
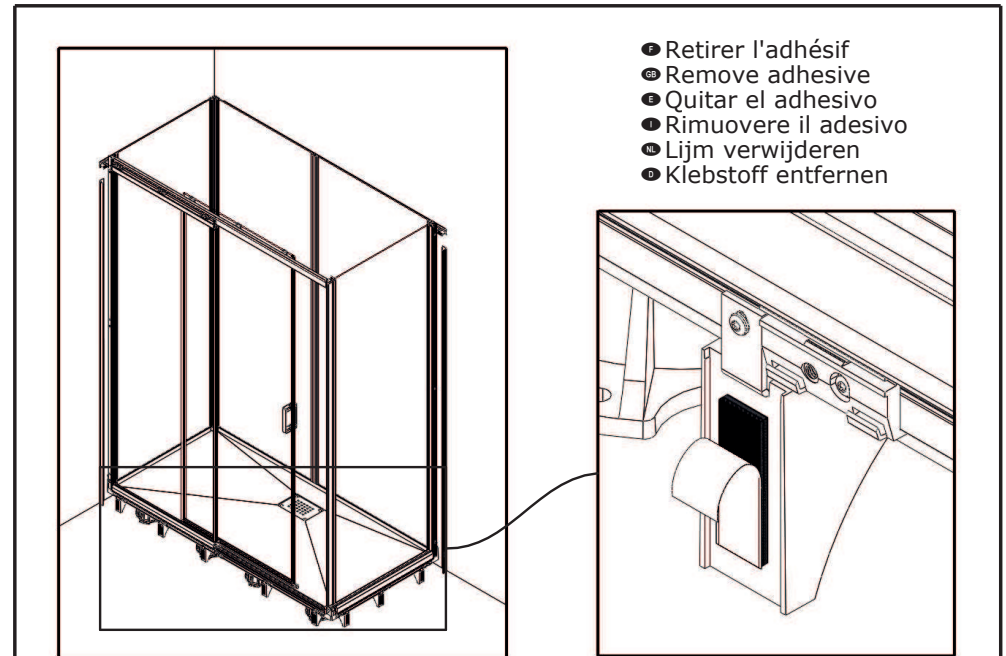
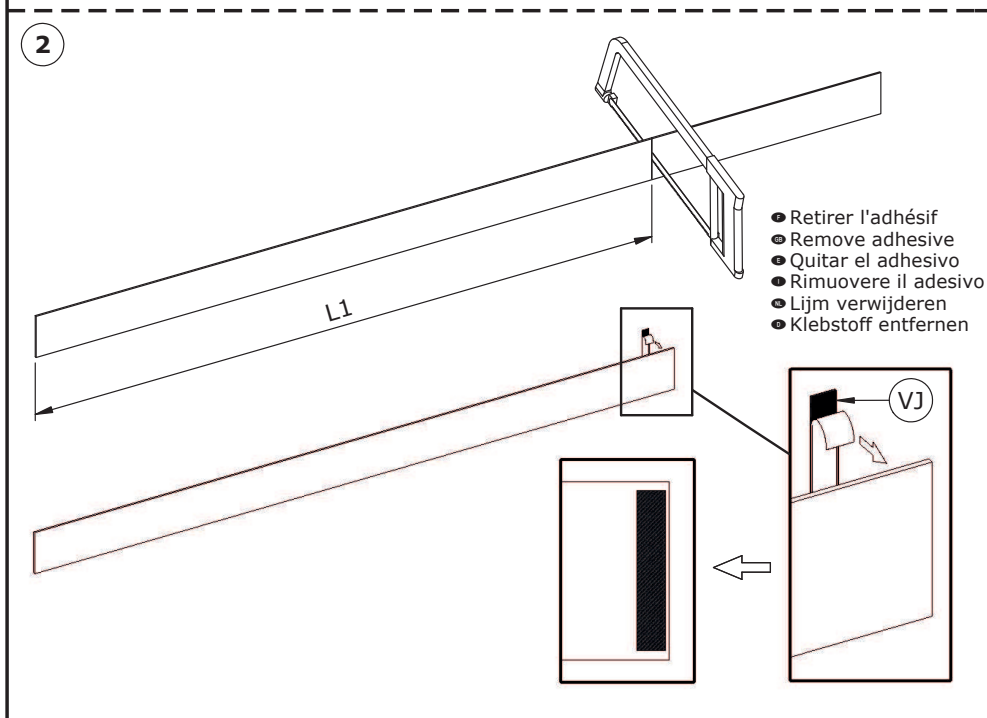
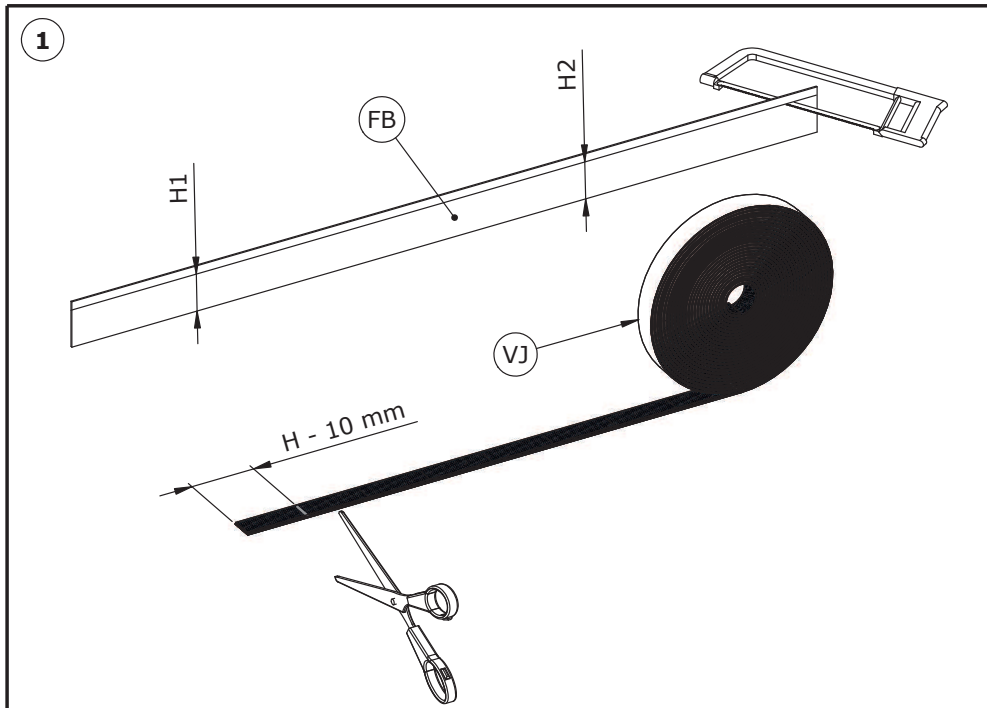

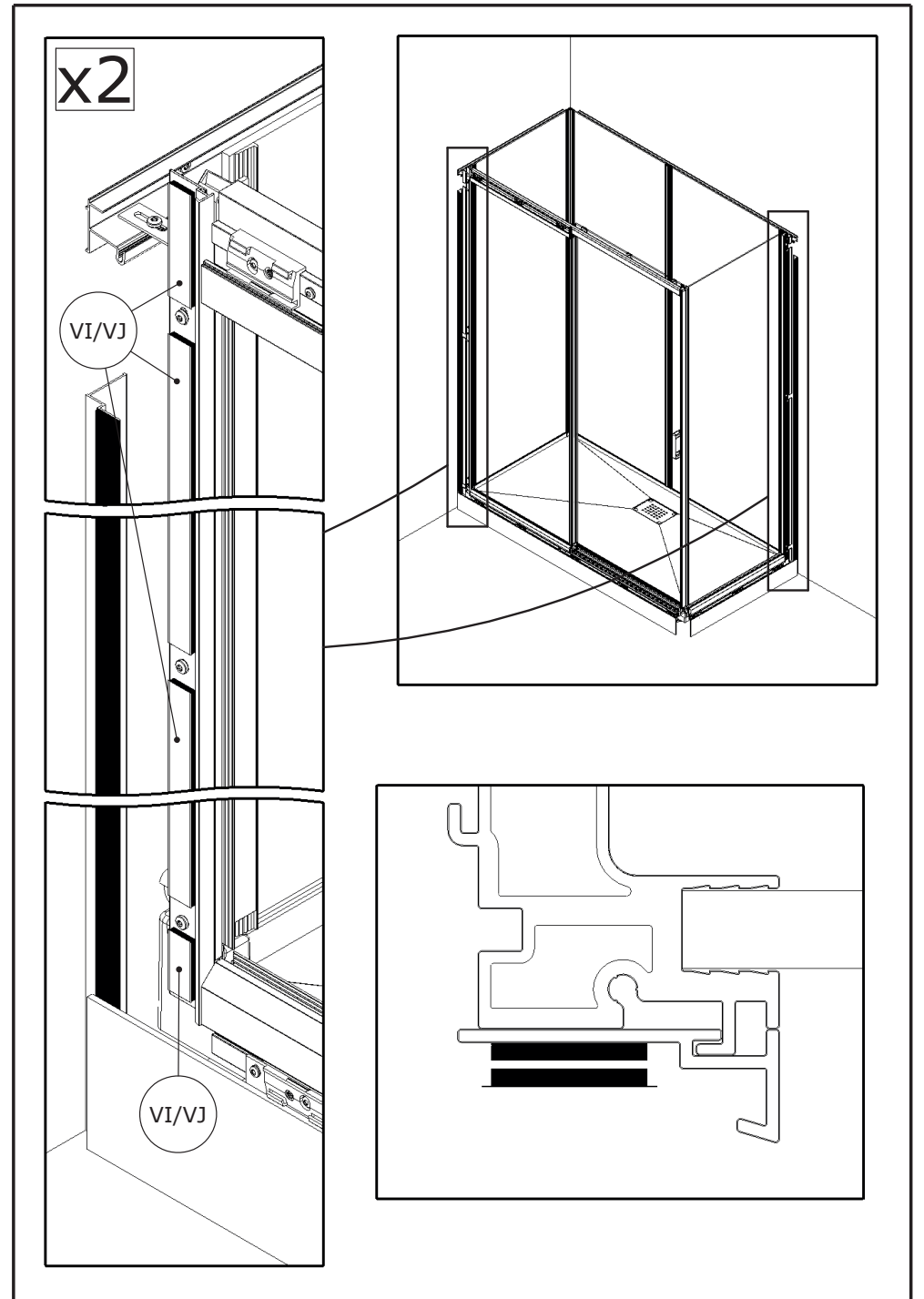
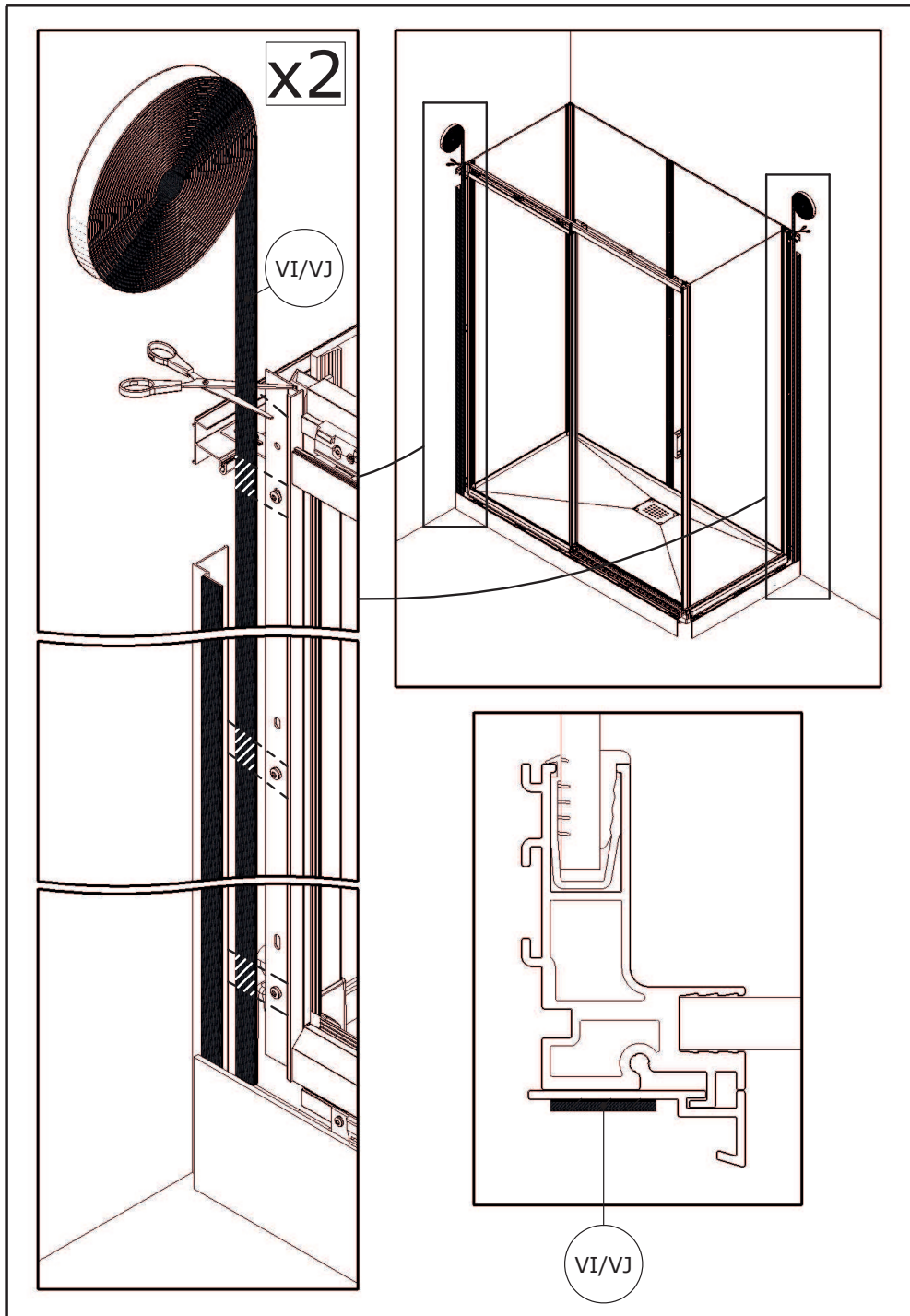

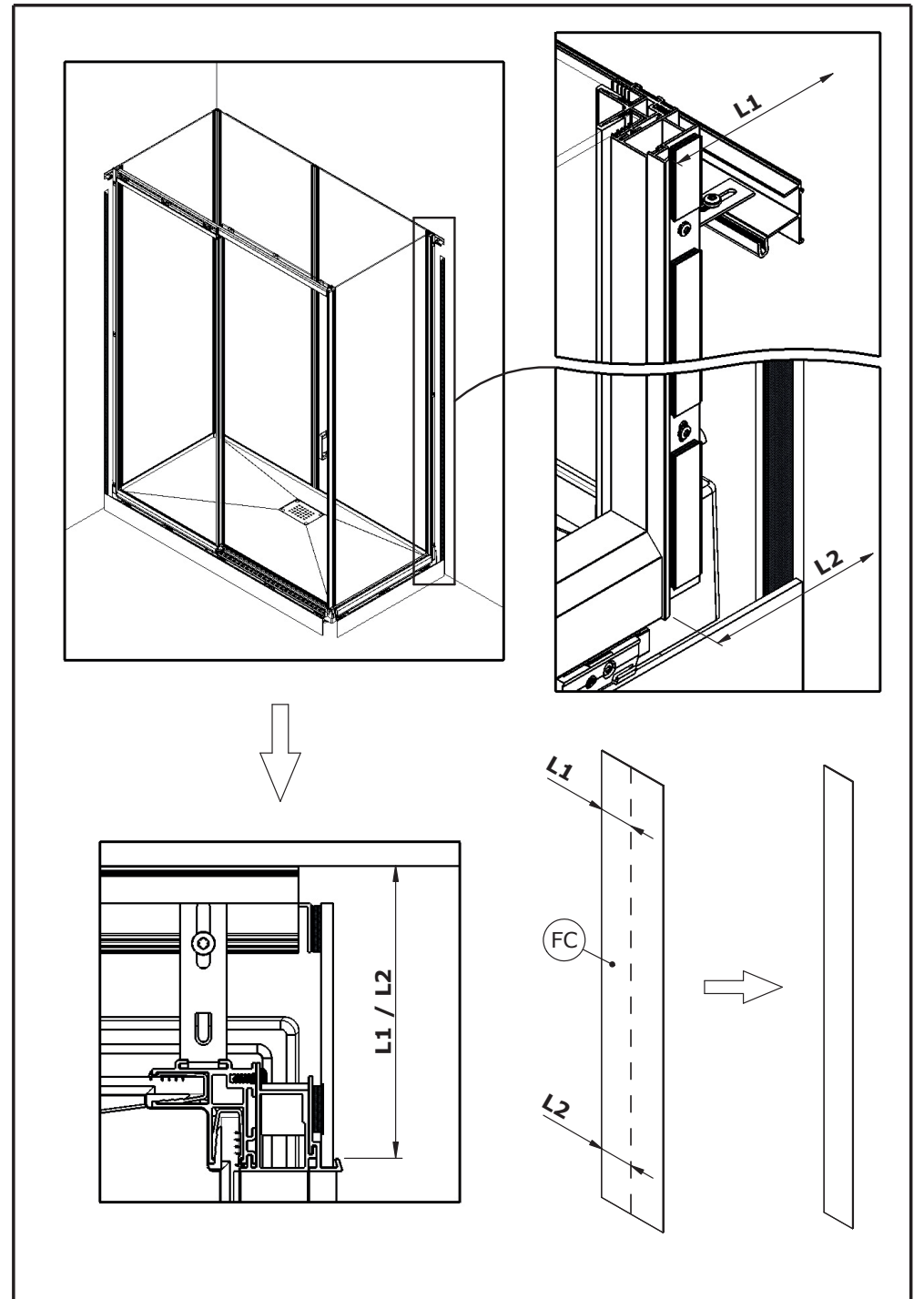
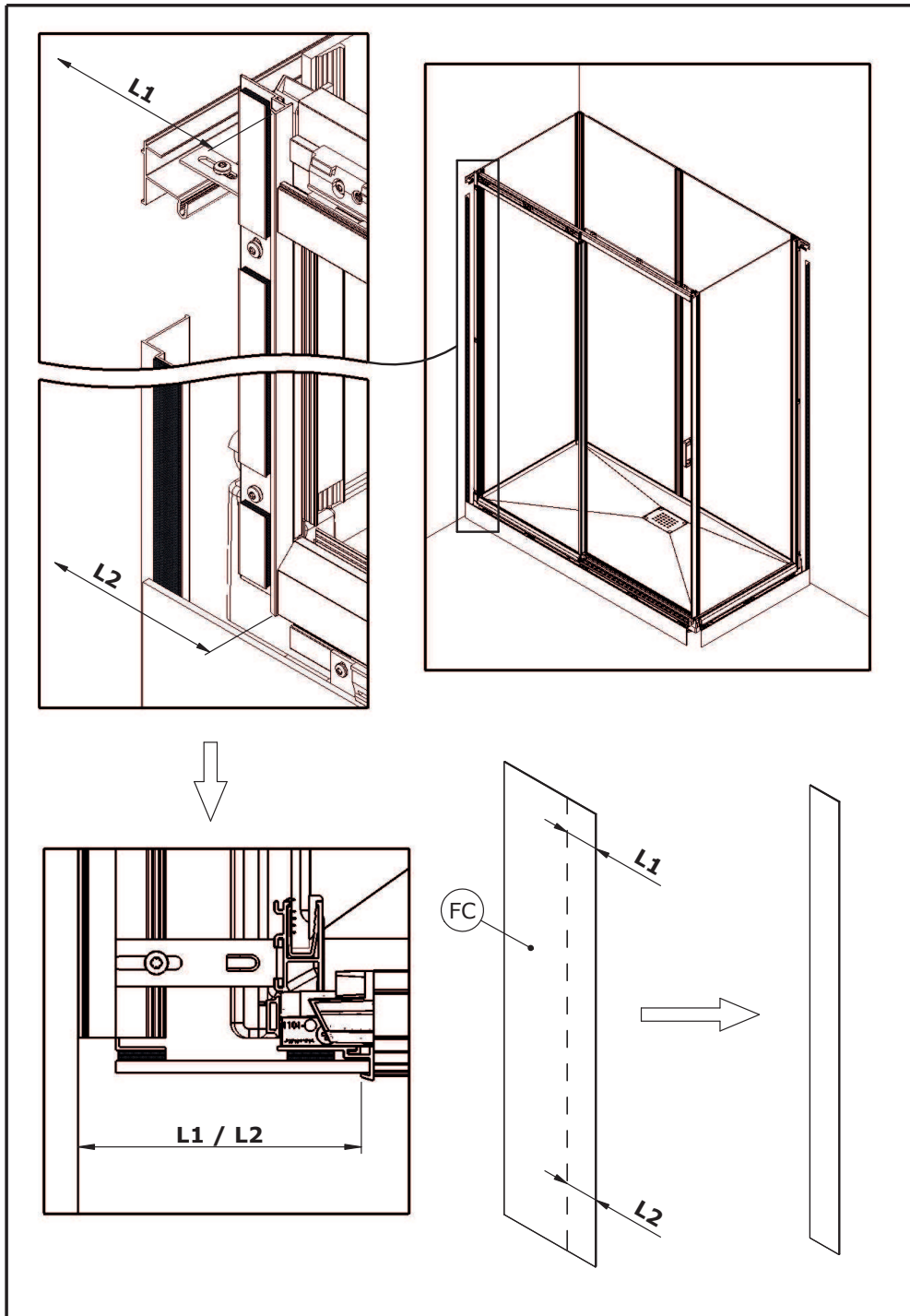

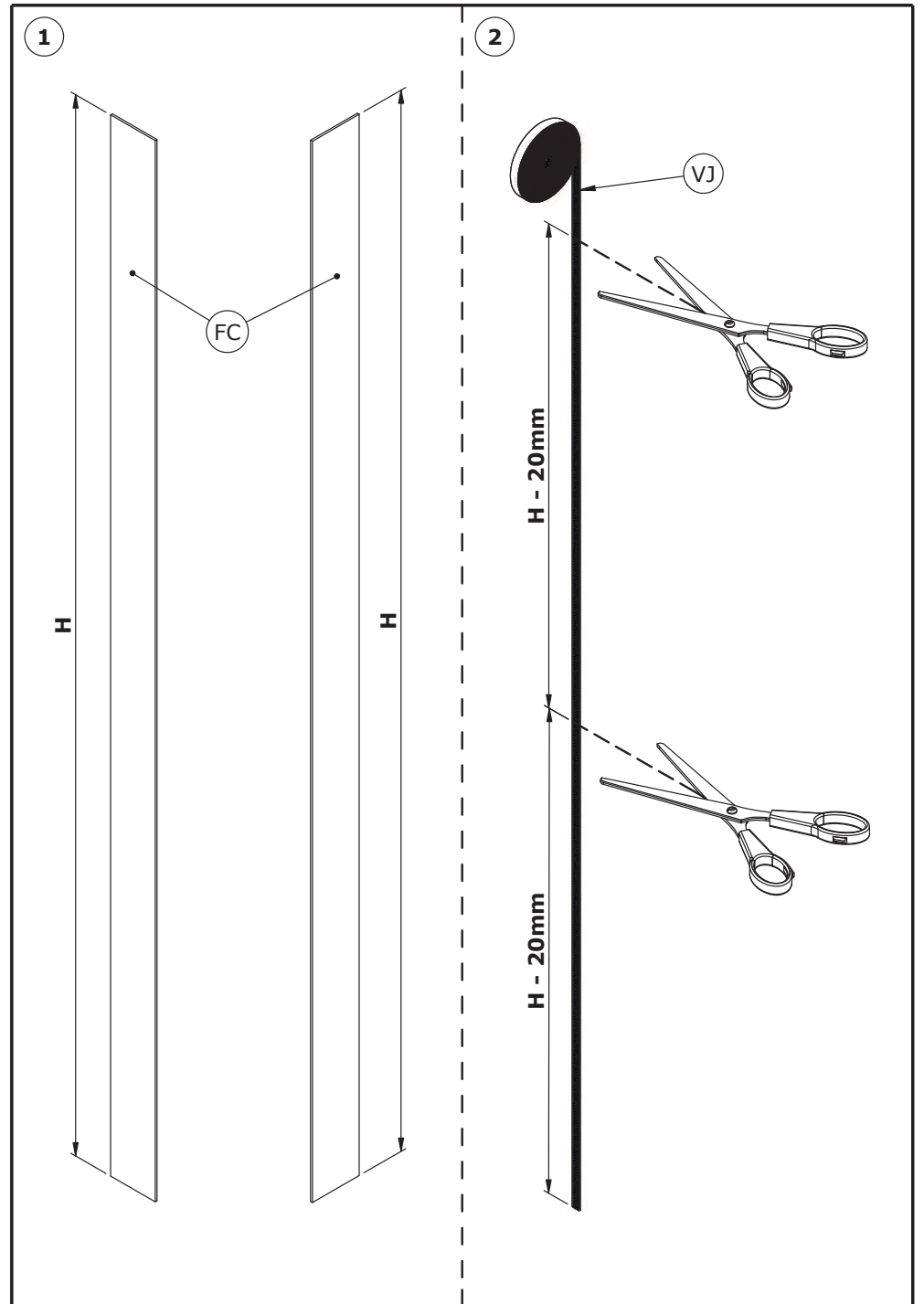
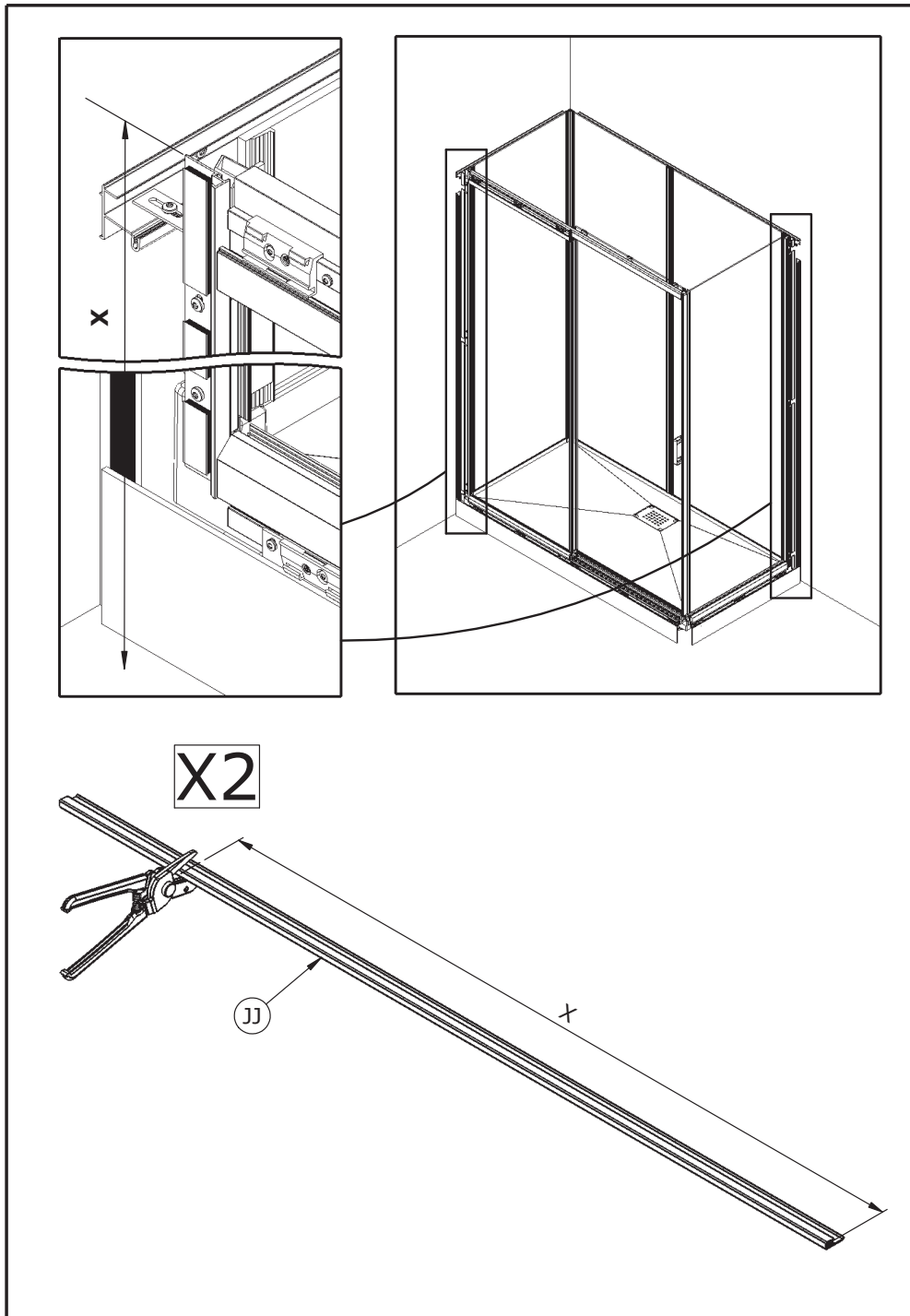

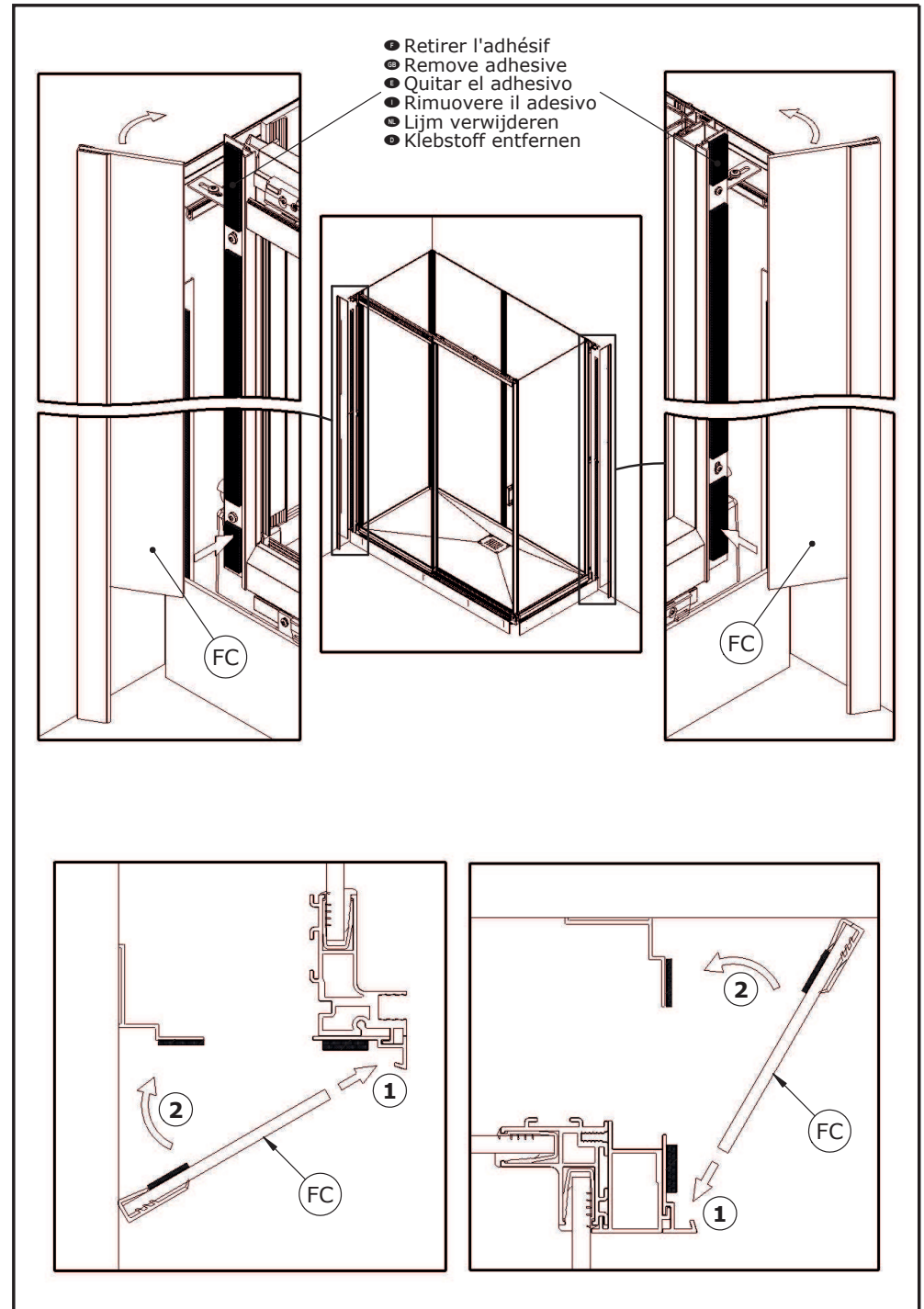
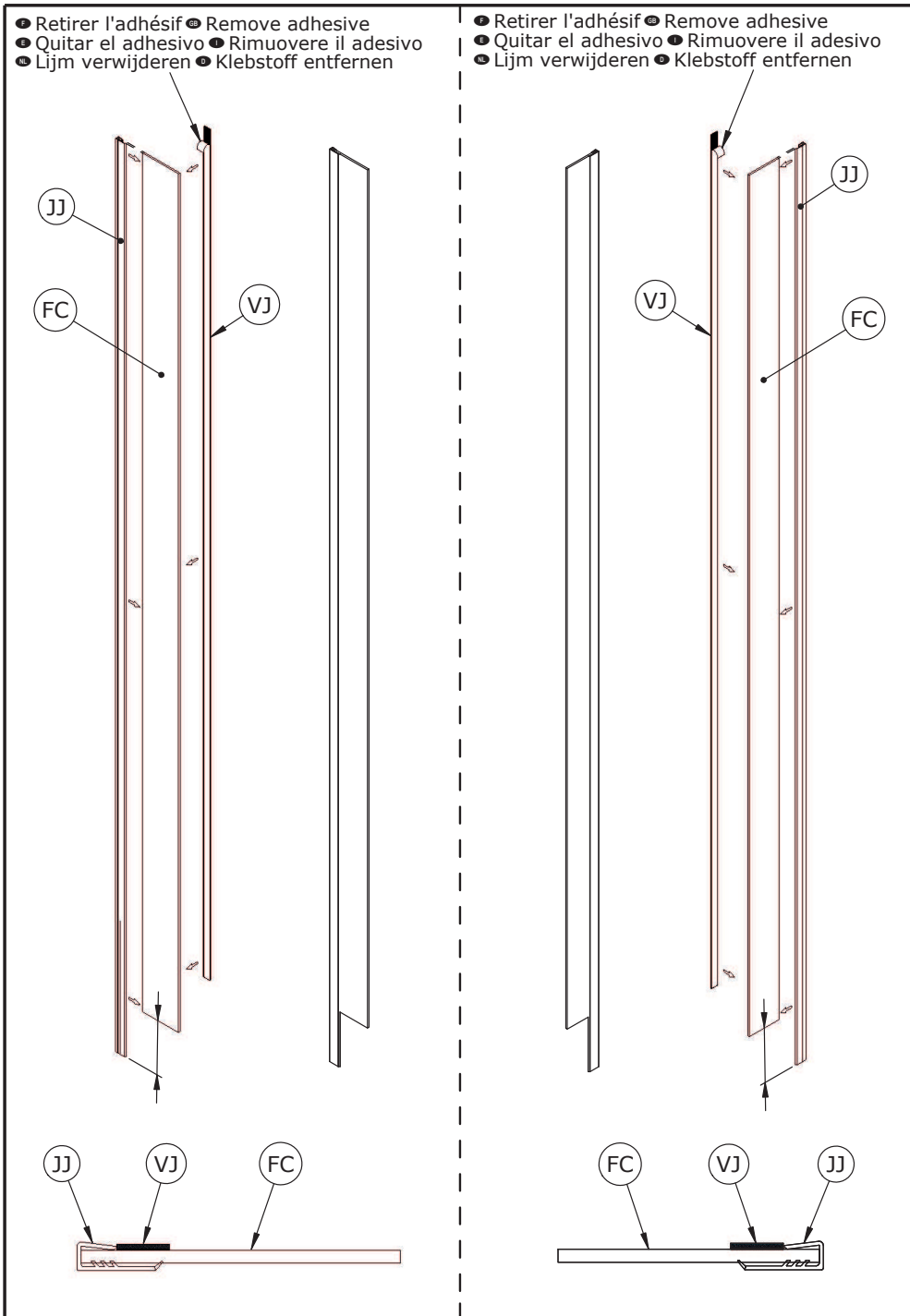

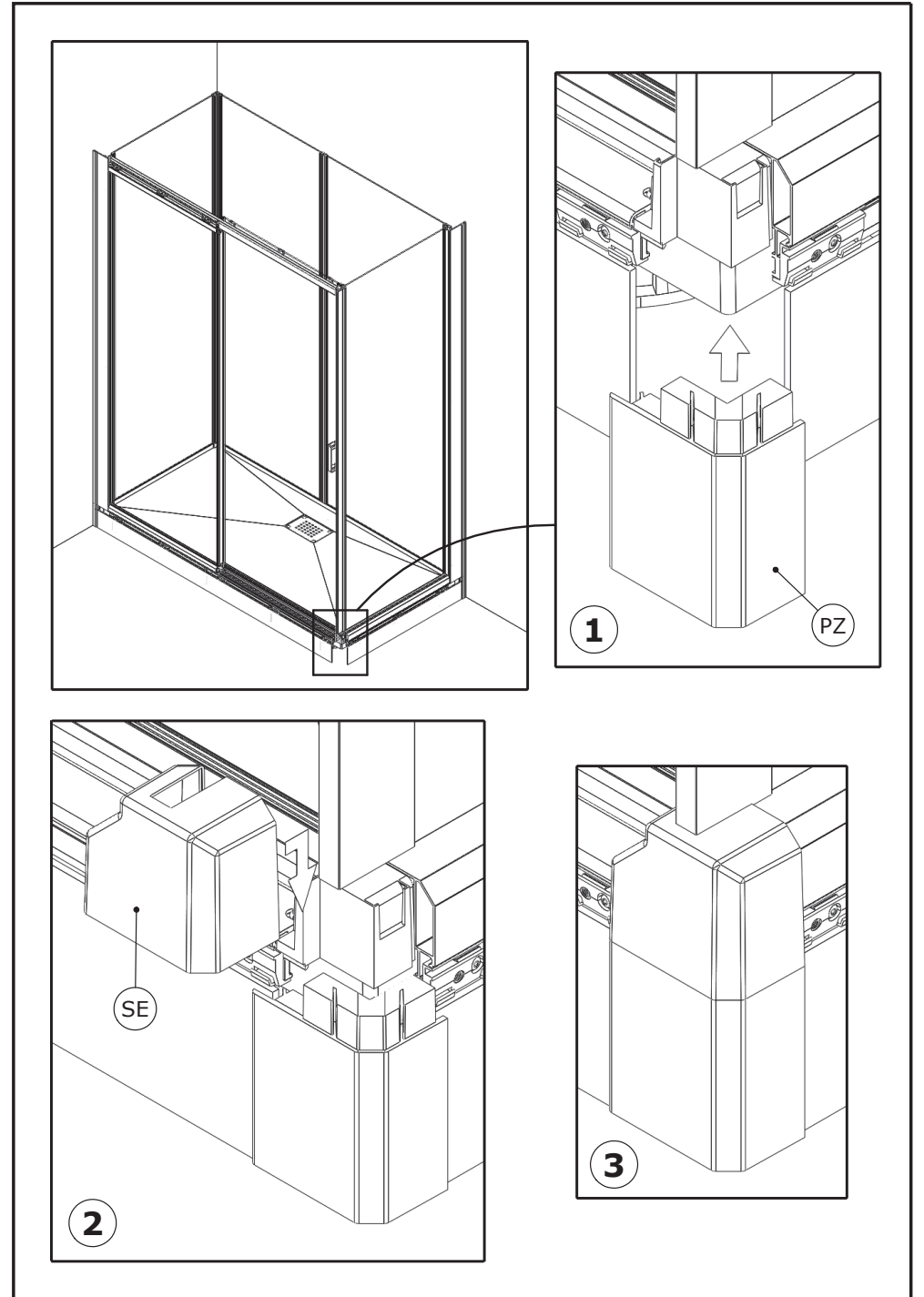
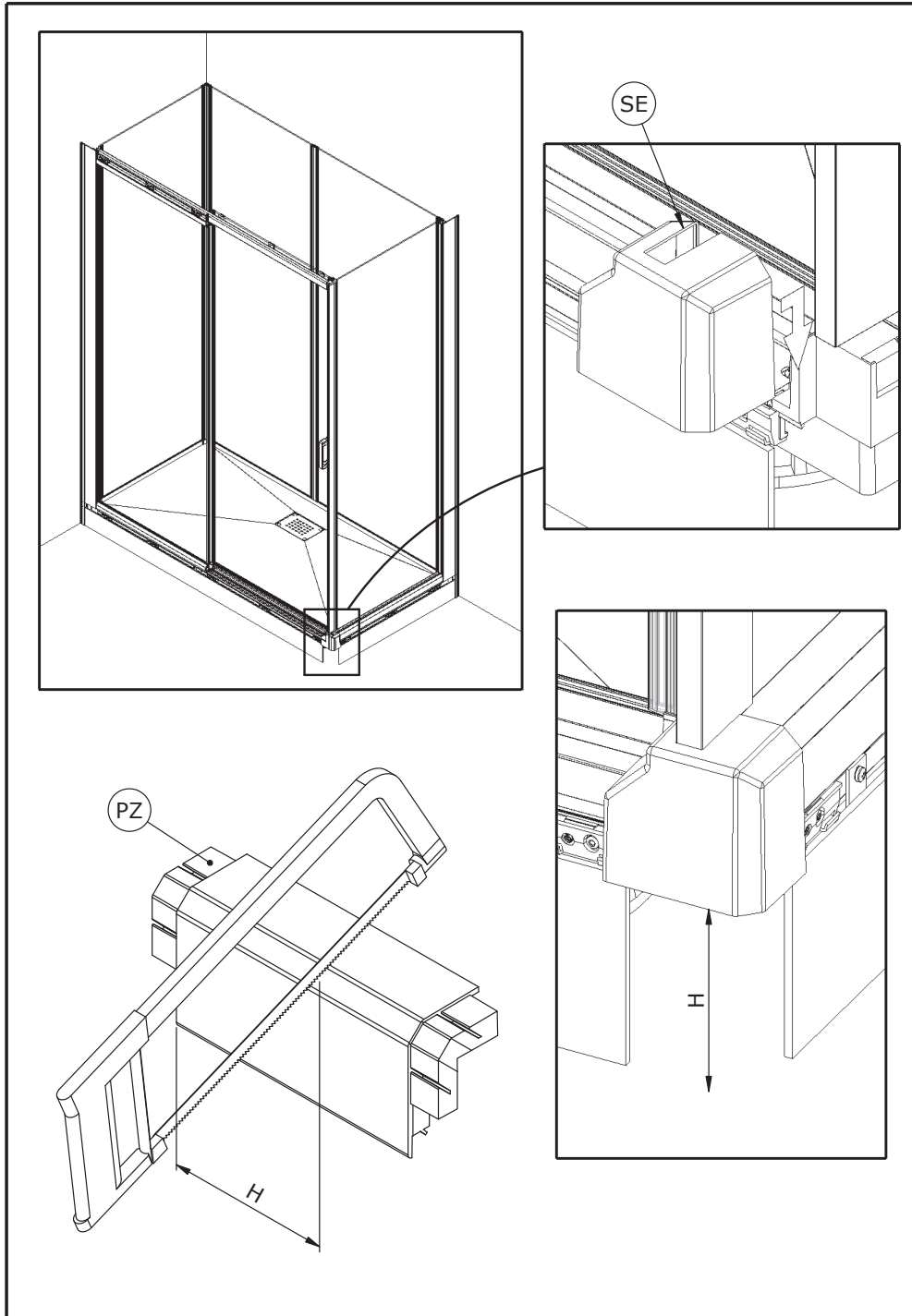

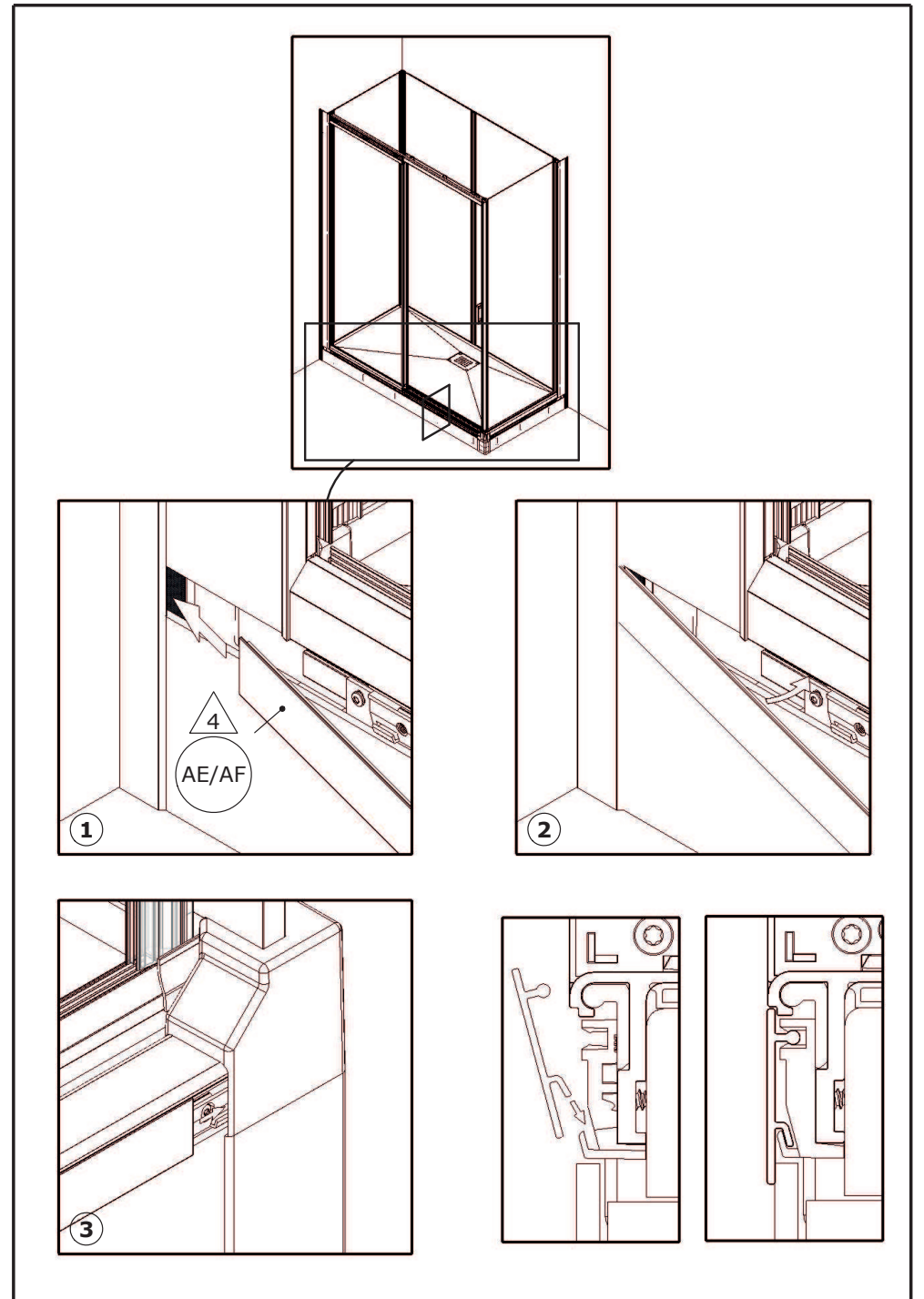
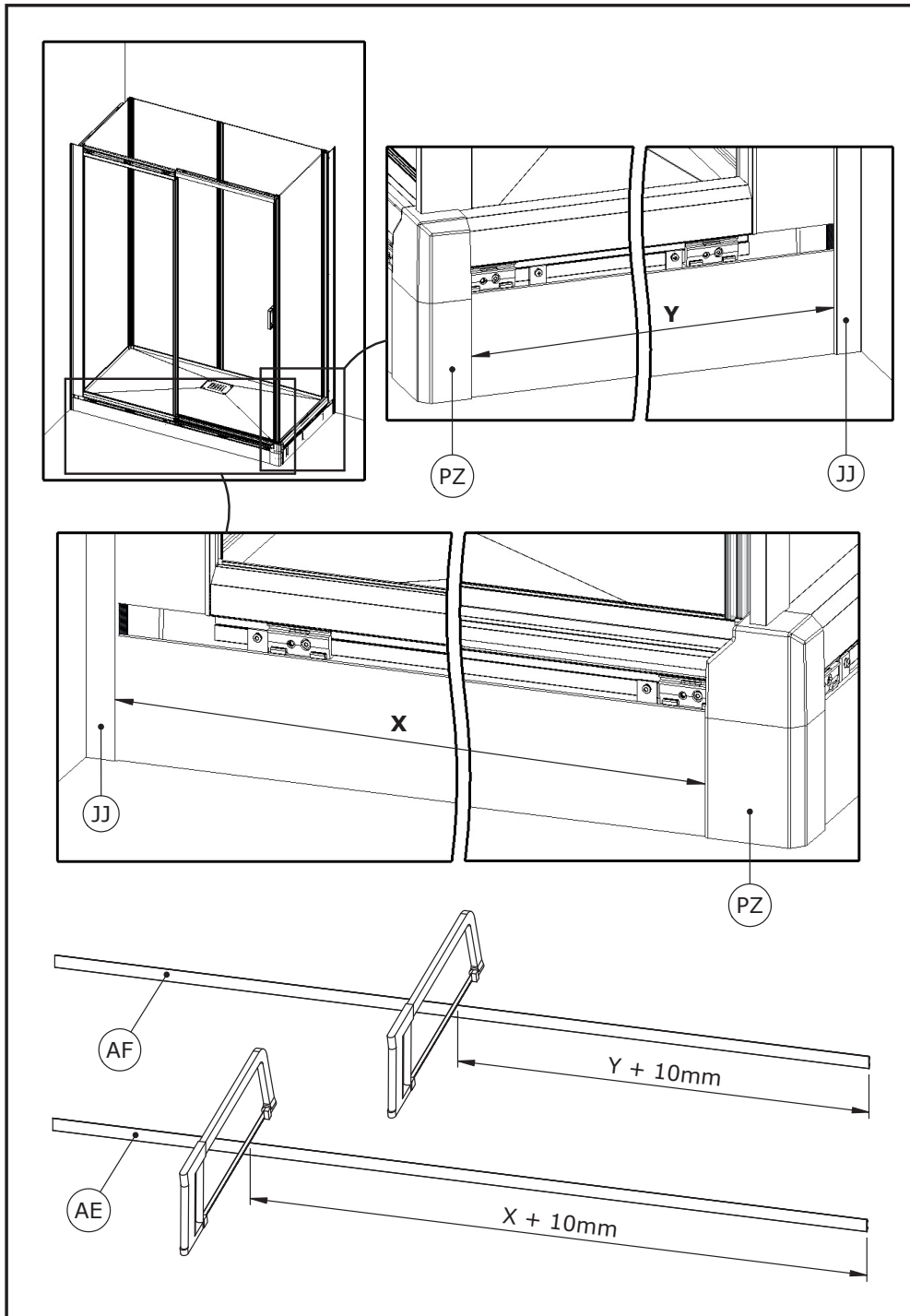

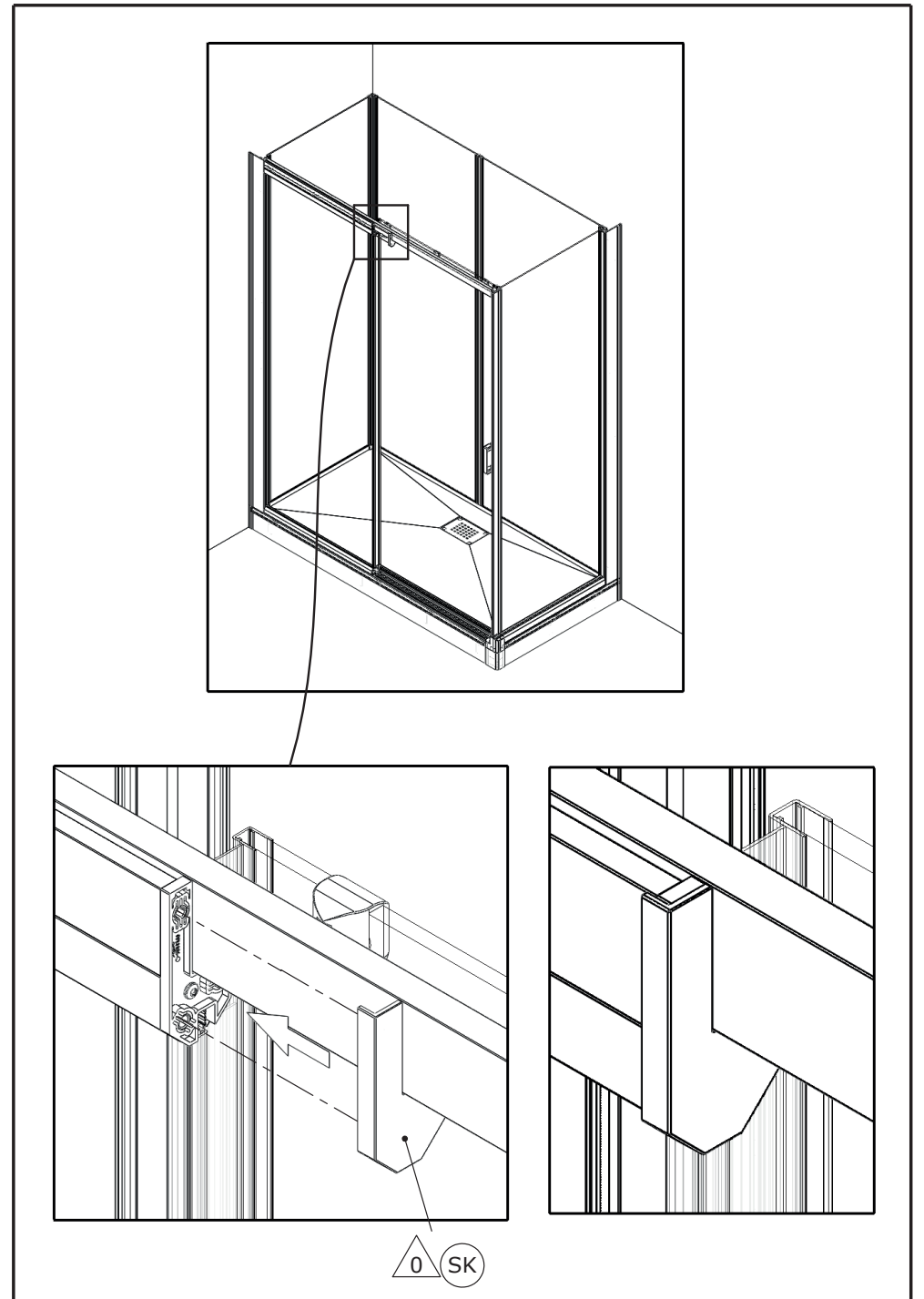
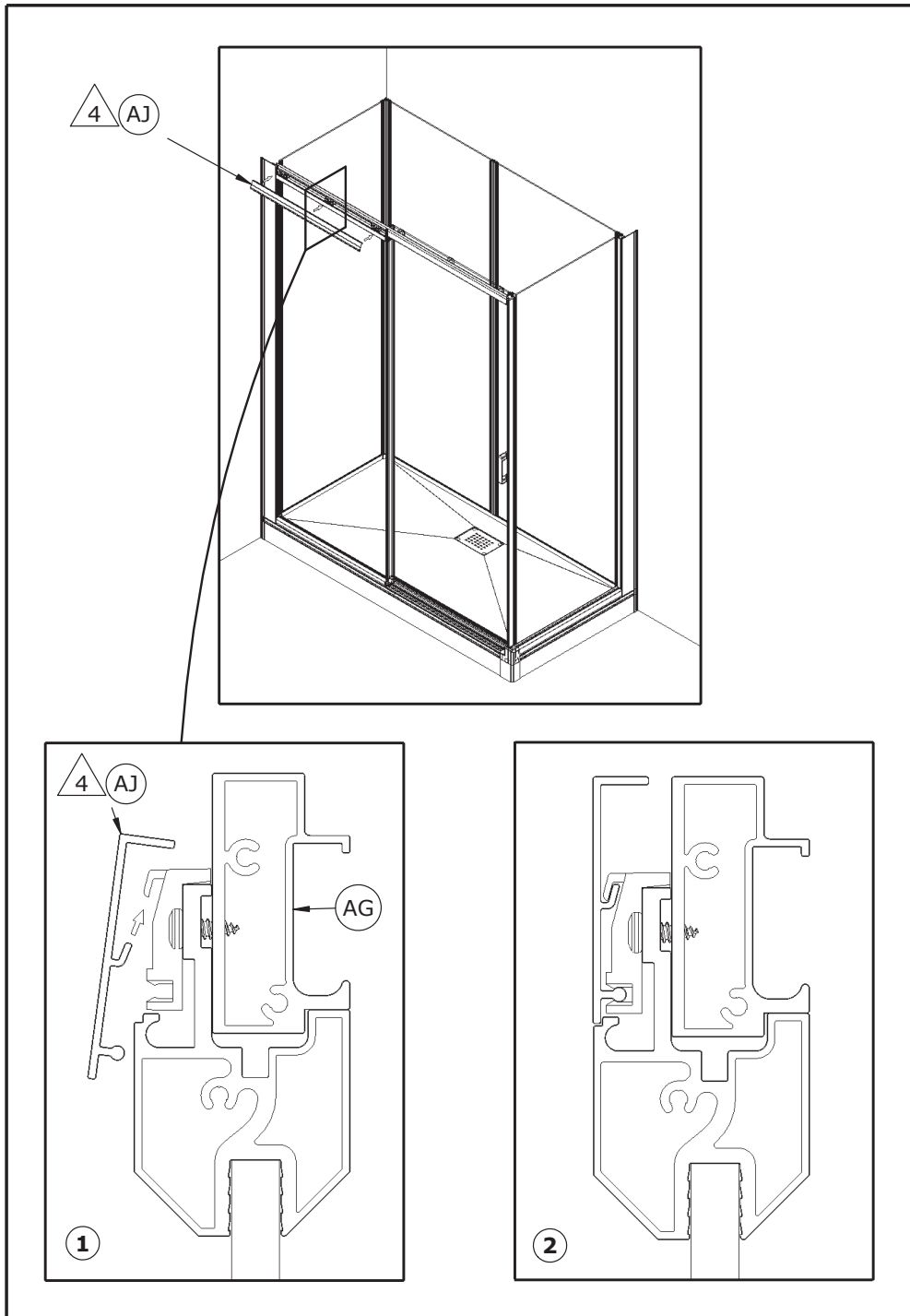

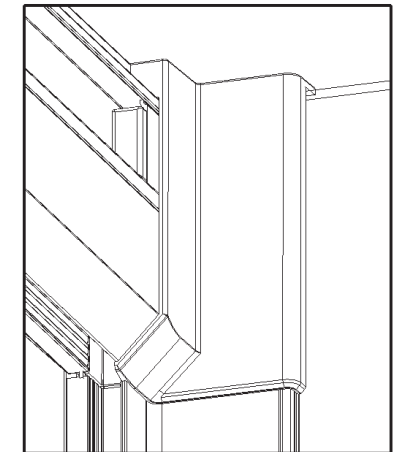
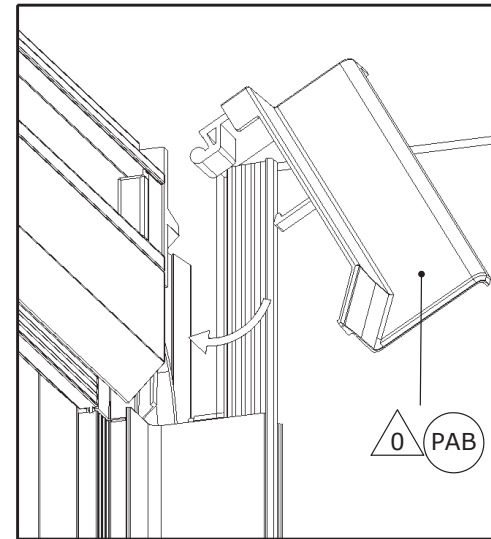
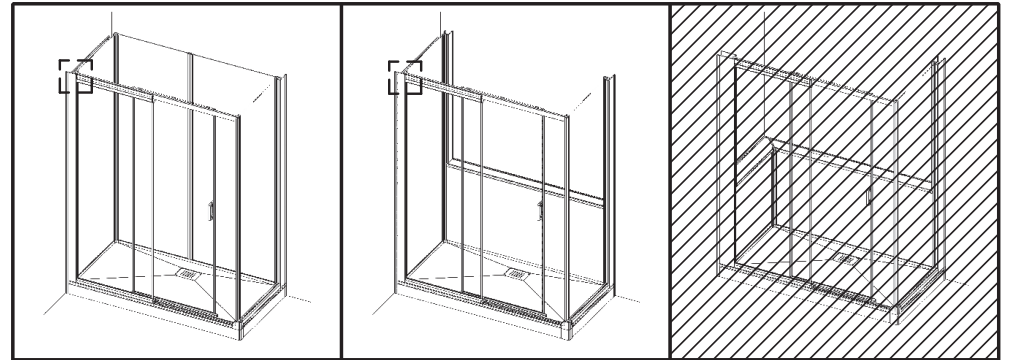
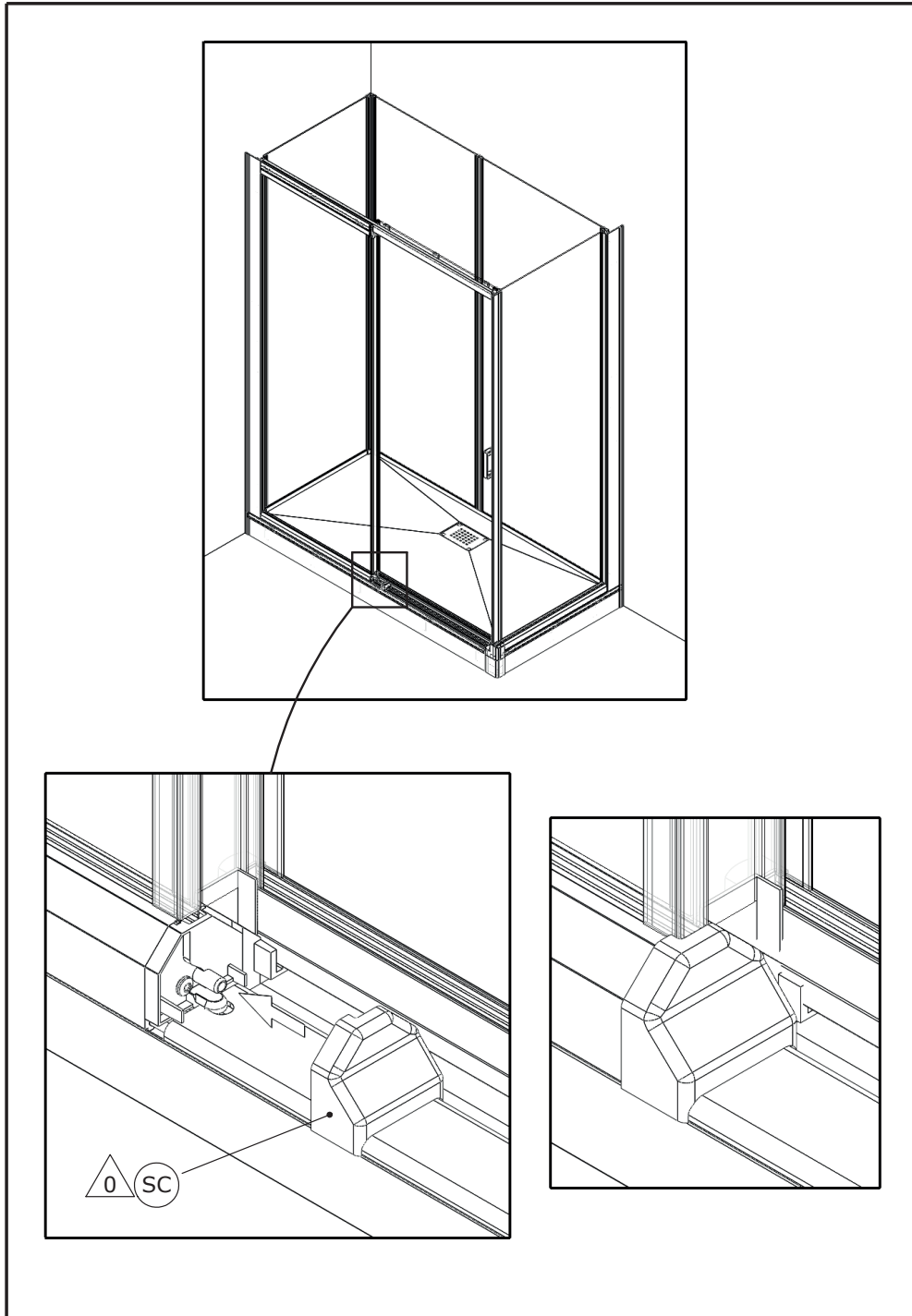

- Intérieur douche ● Inside shower
- Interior ducha ● Doccia interni
- Binnen douche ● Innenraum der Kabine

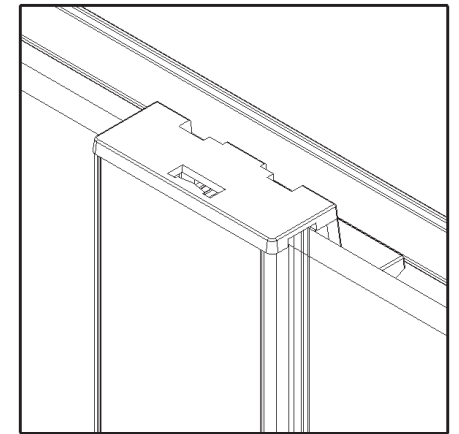
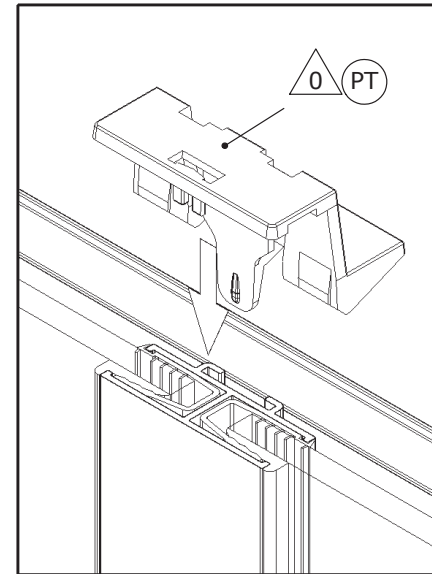
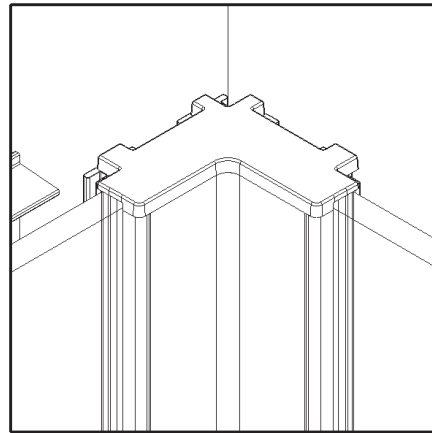
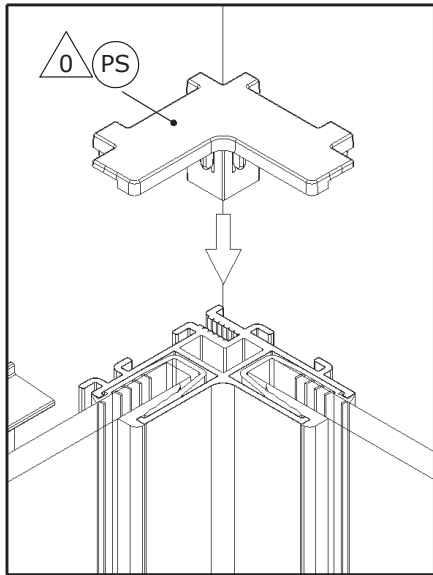
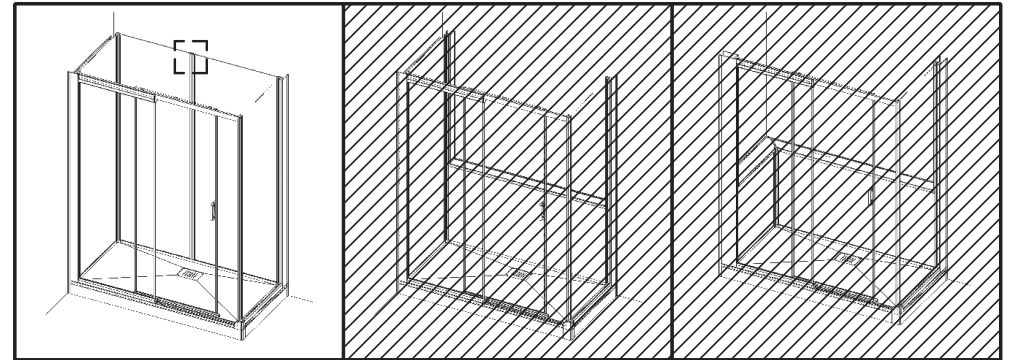
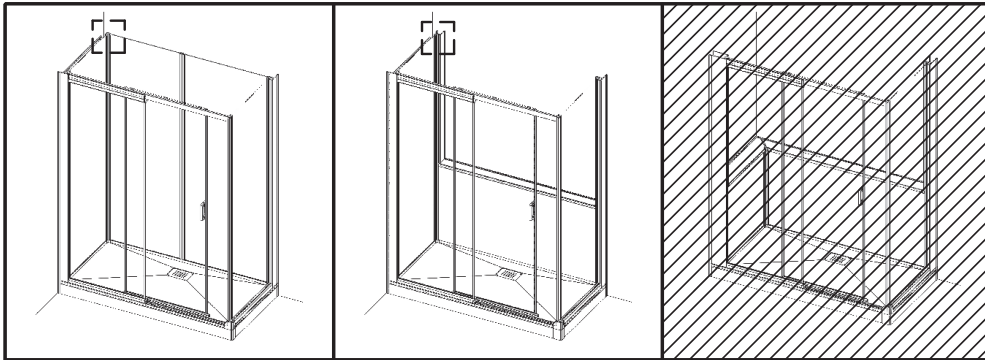

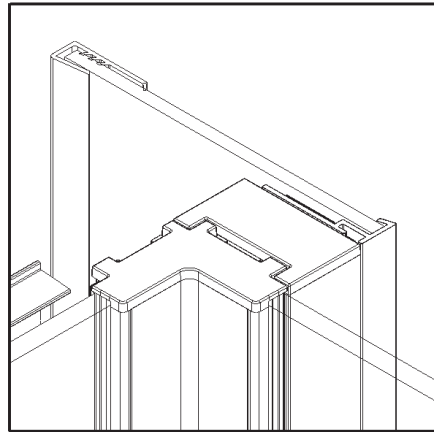
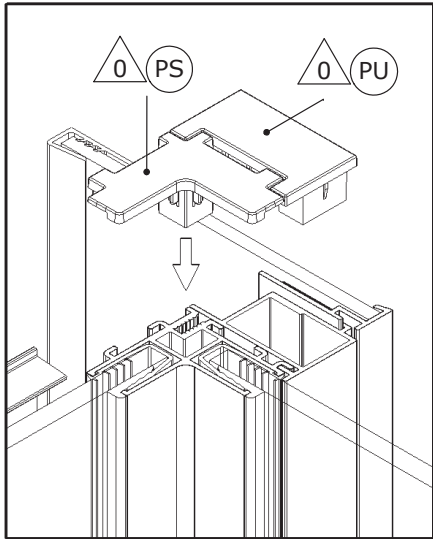
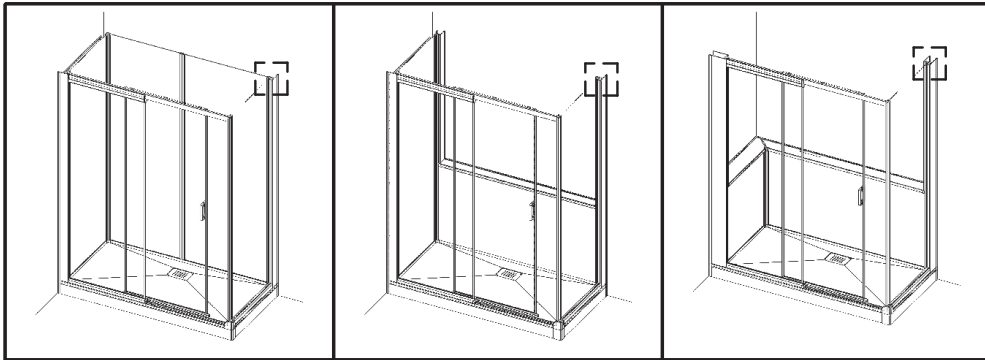

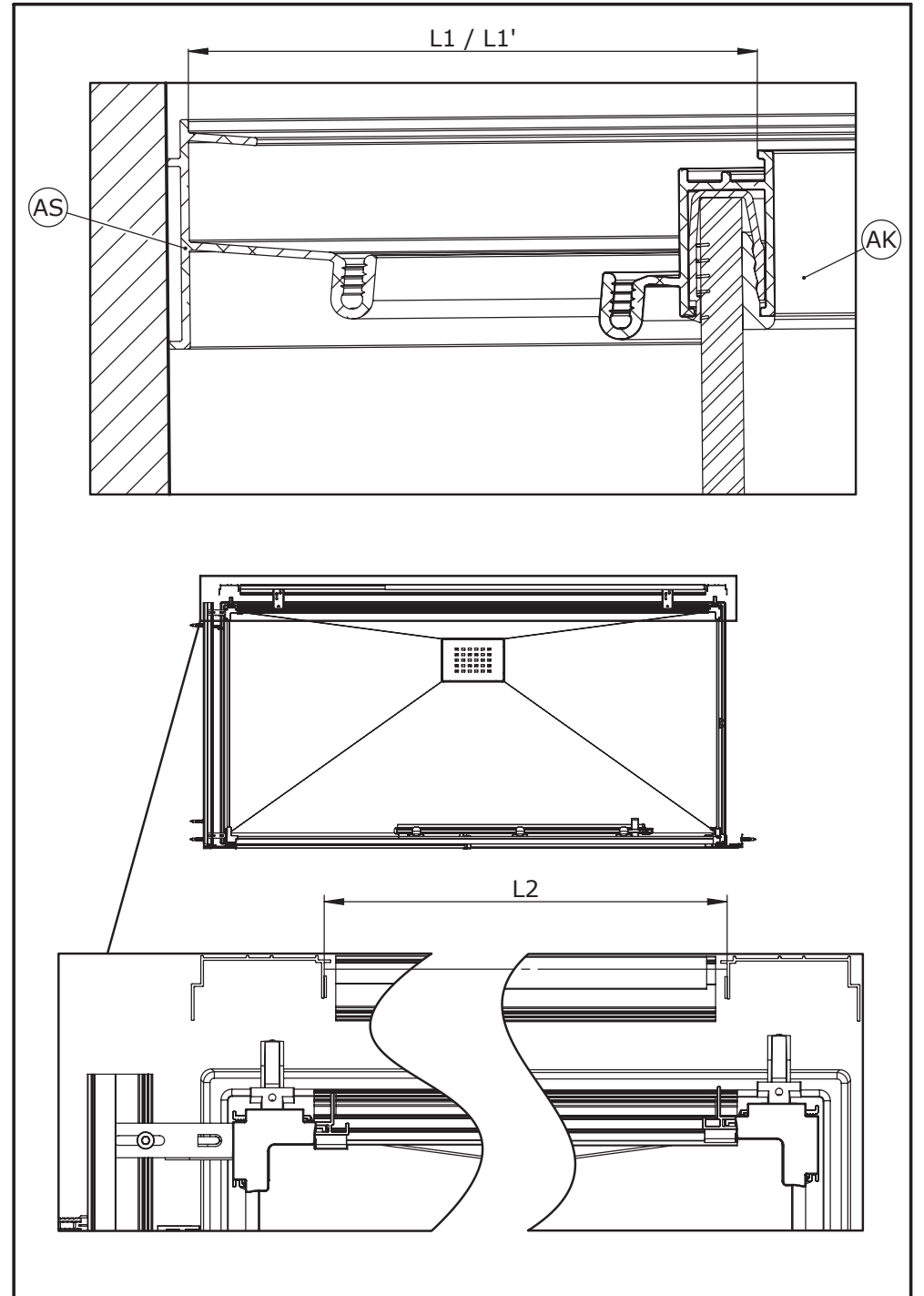
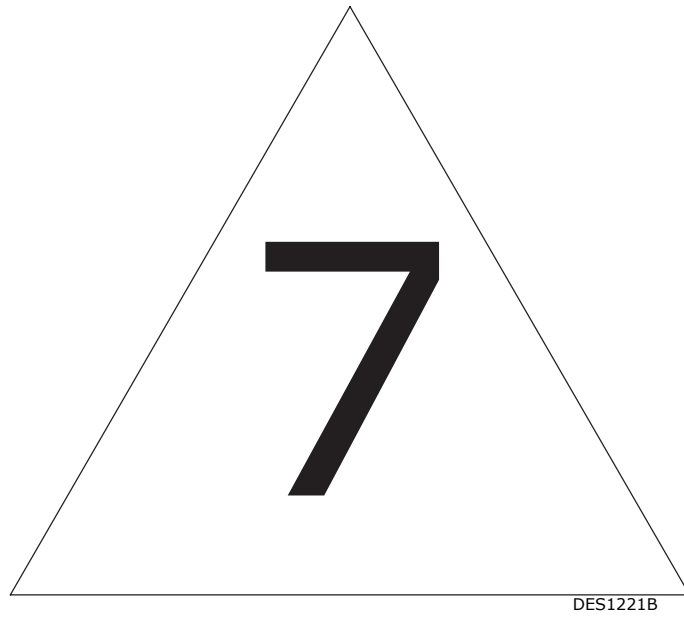

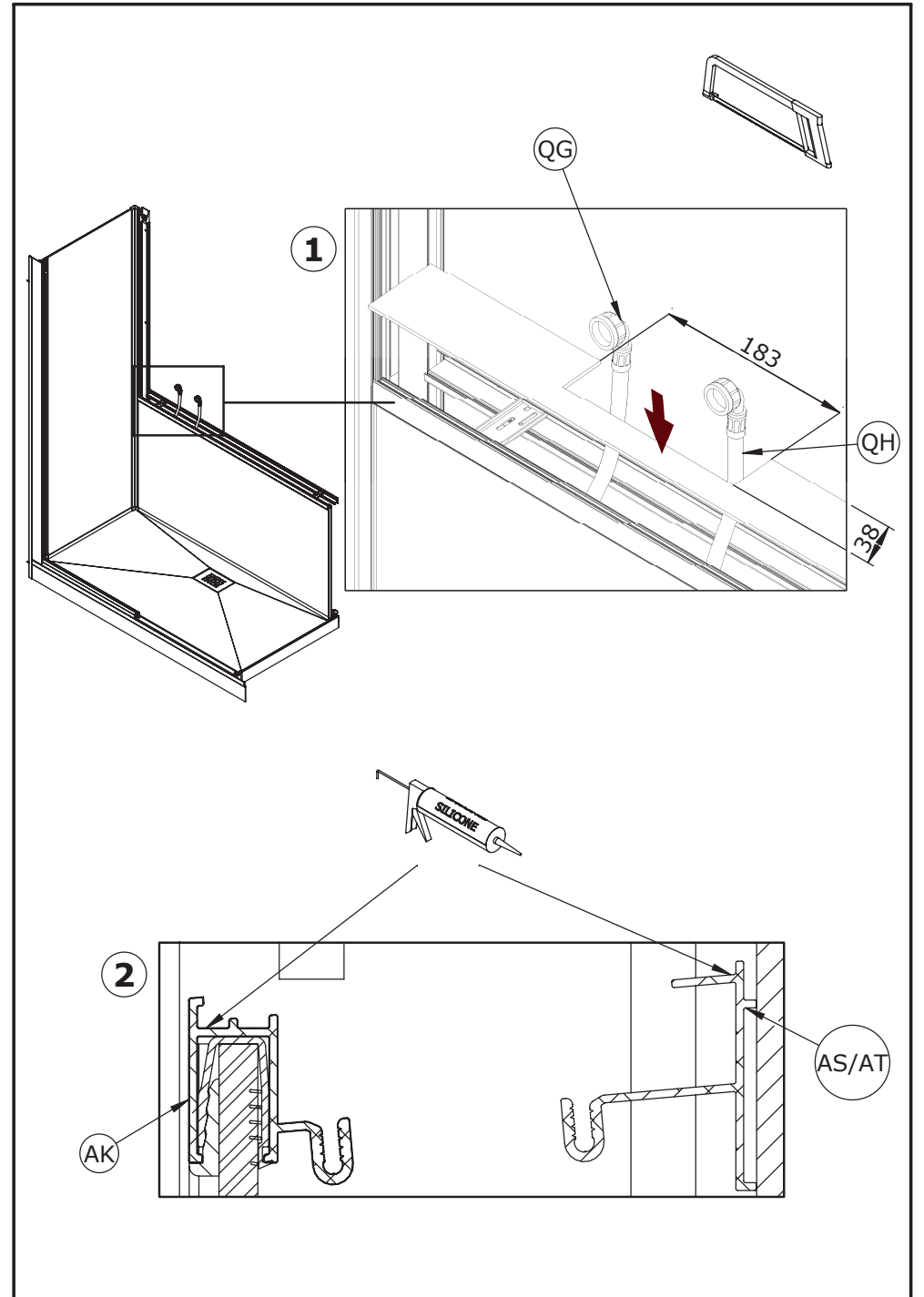
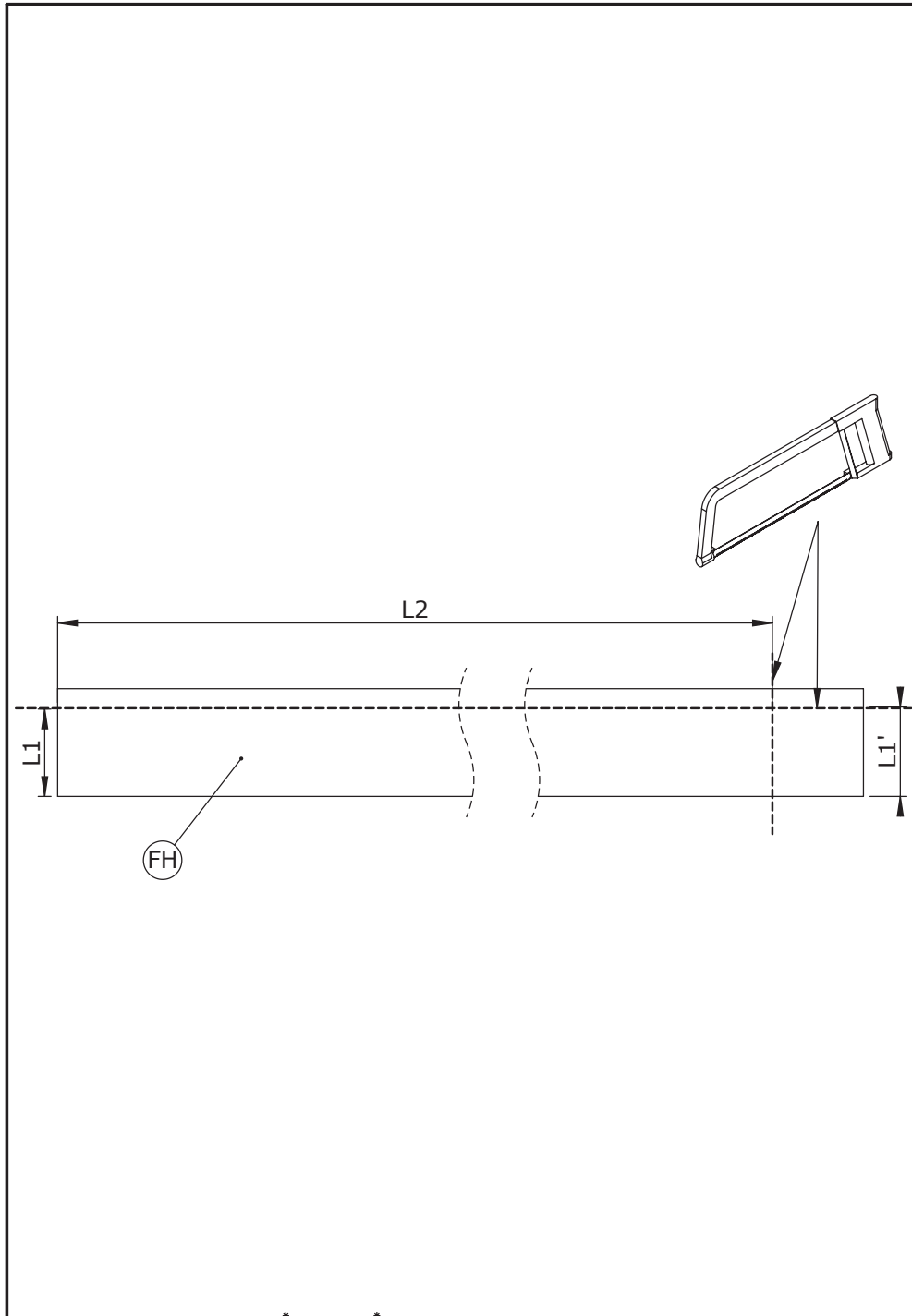

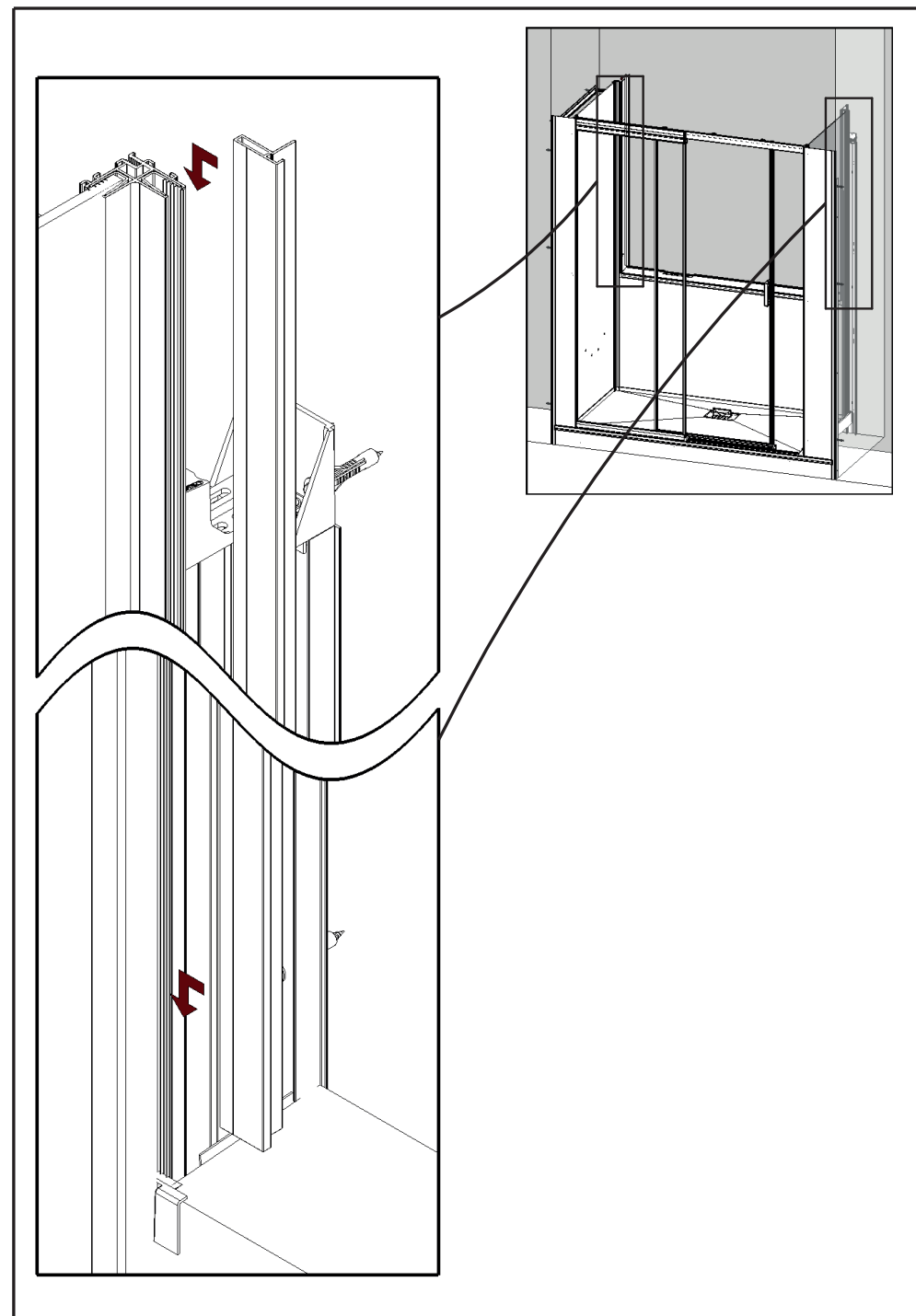
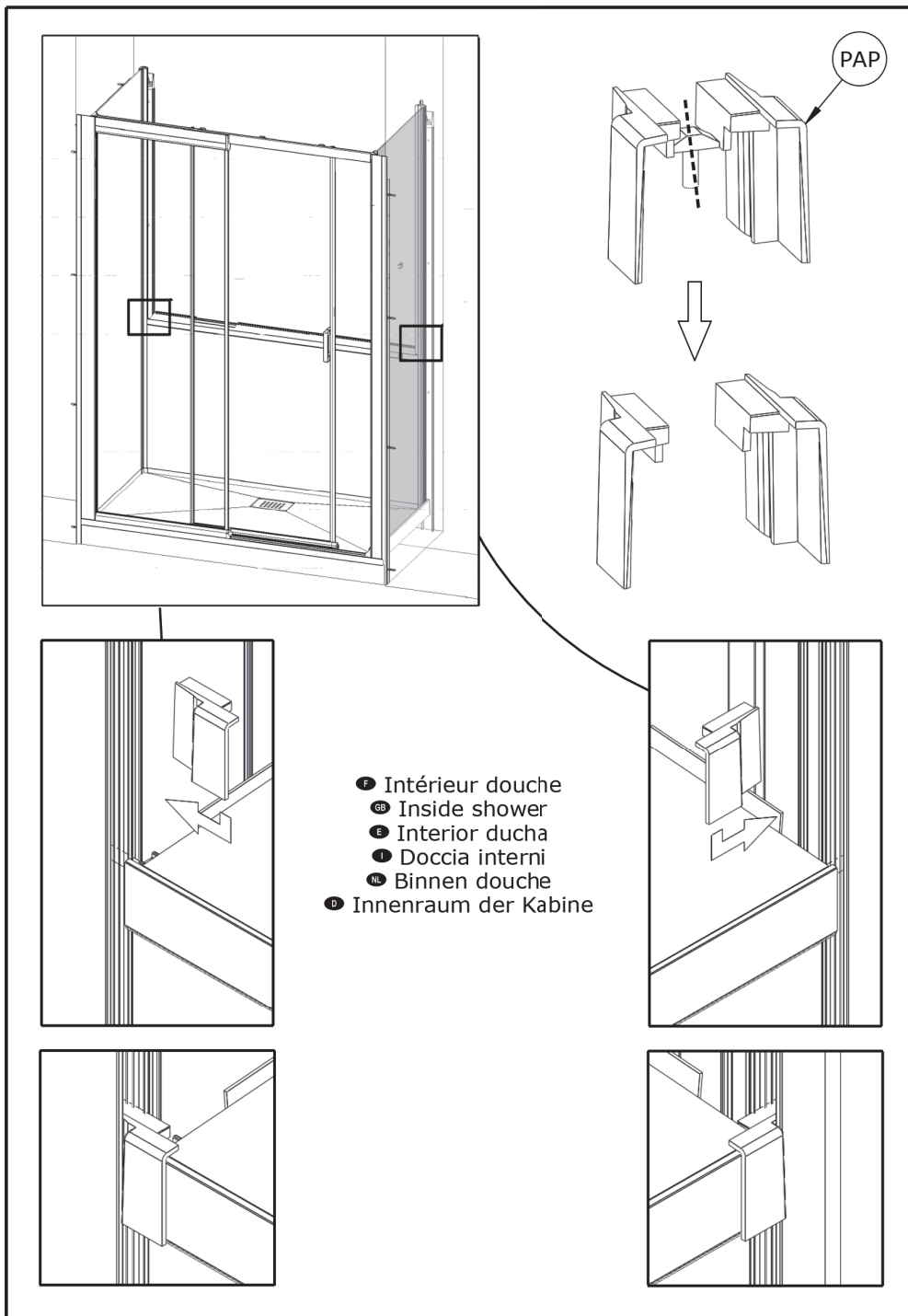

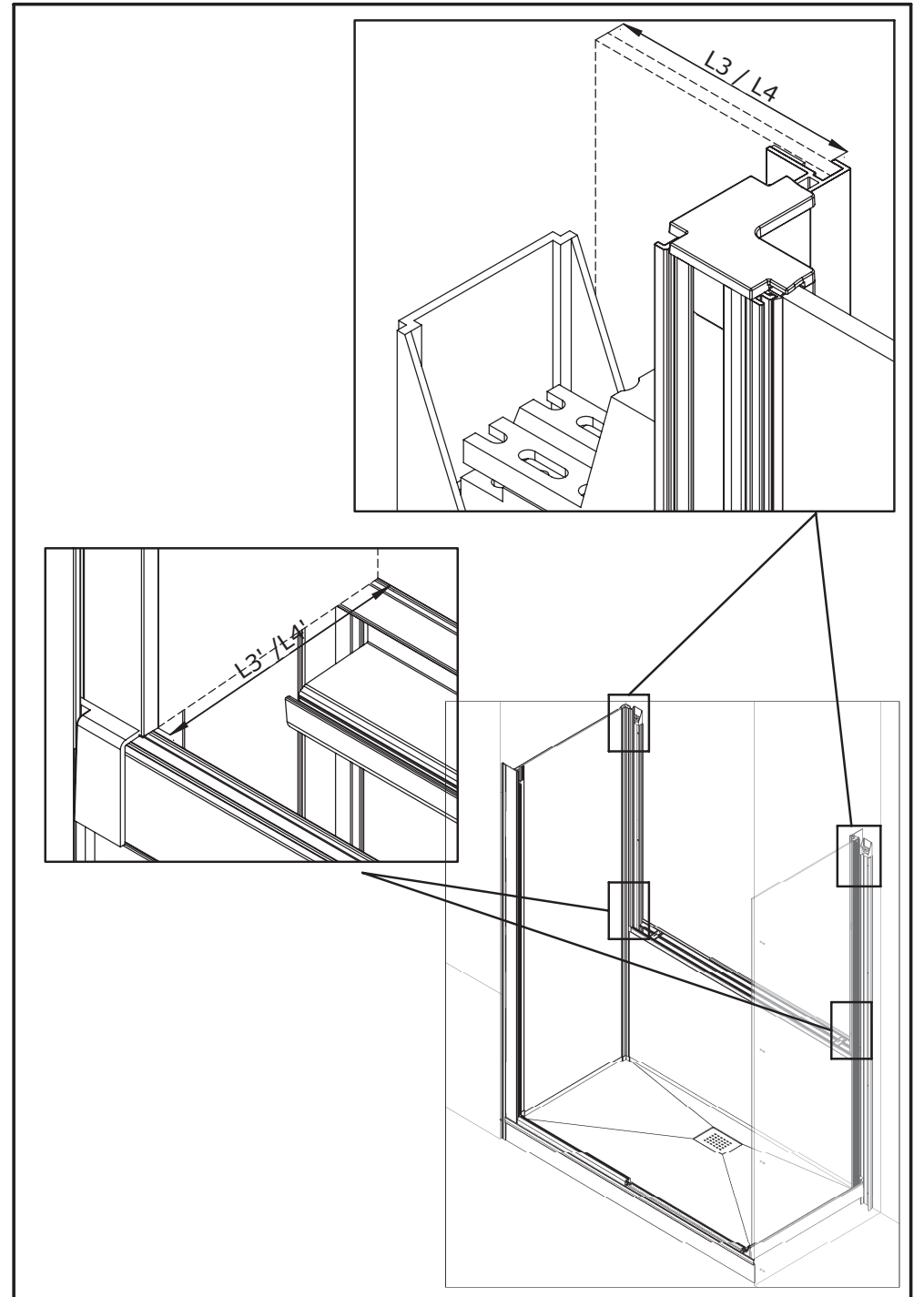
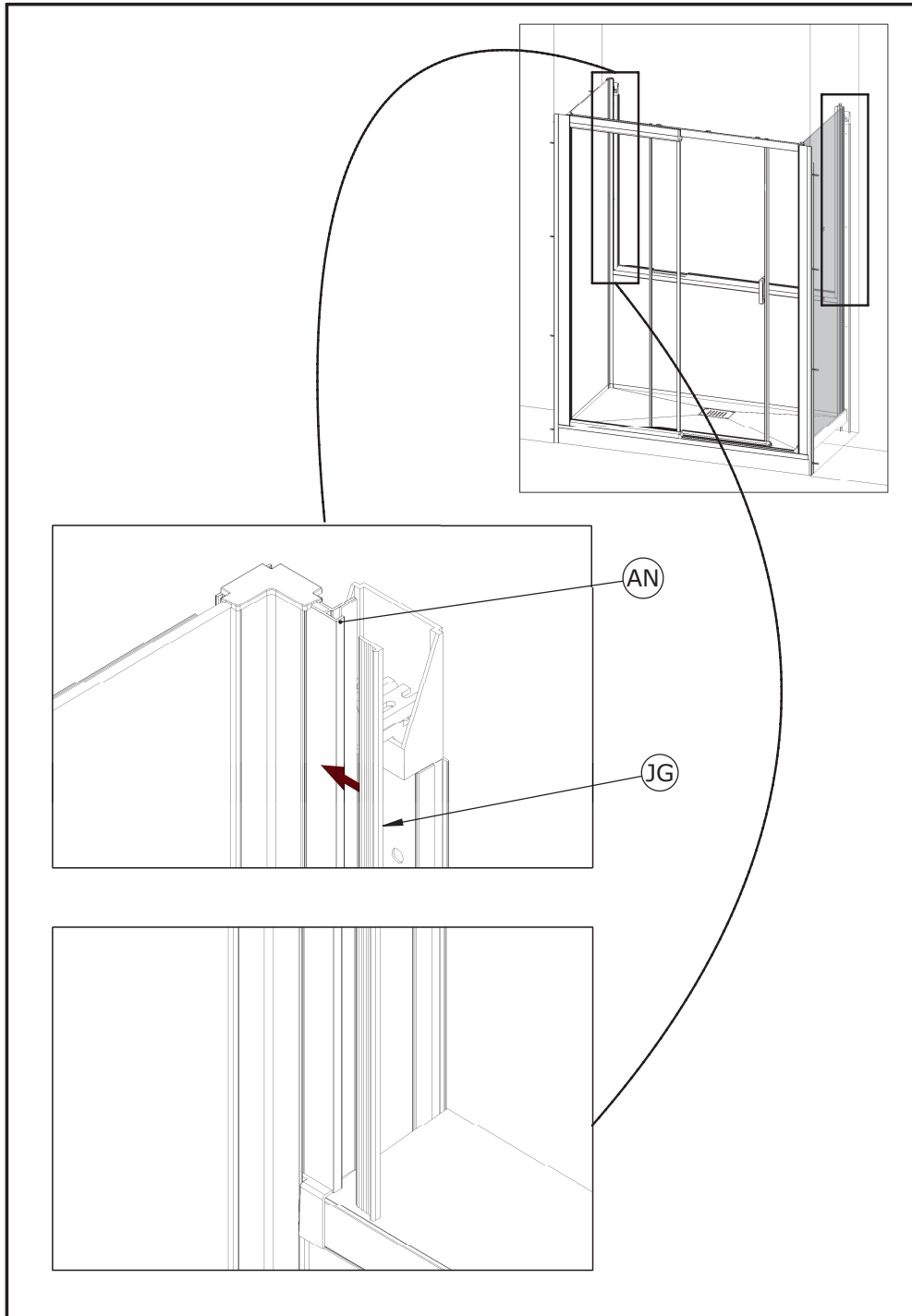

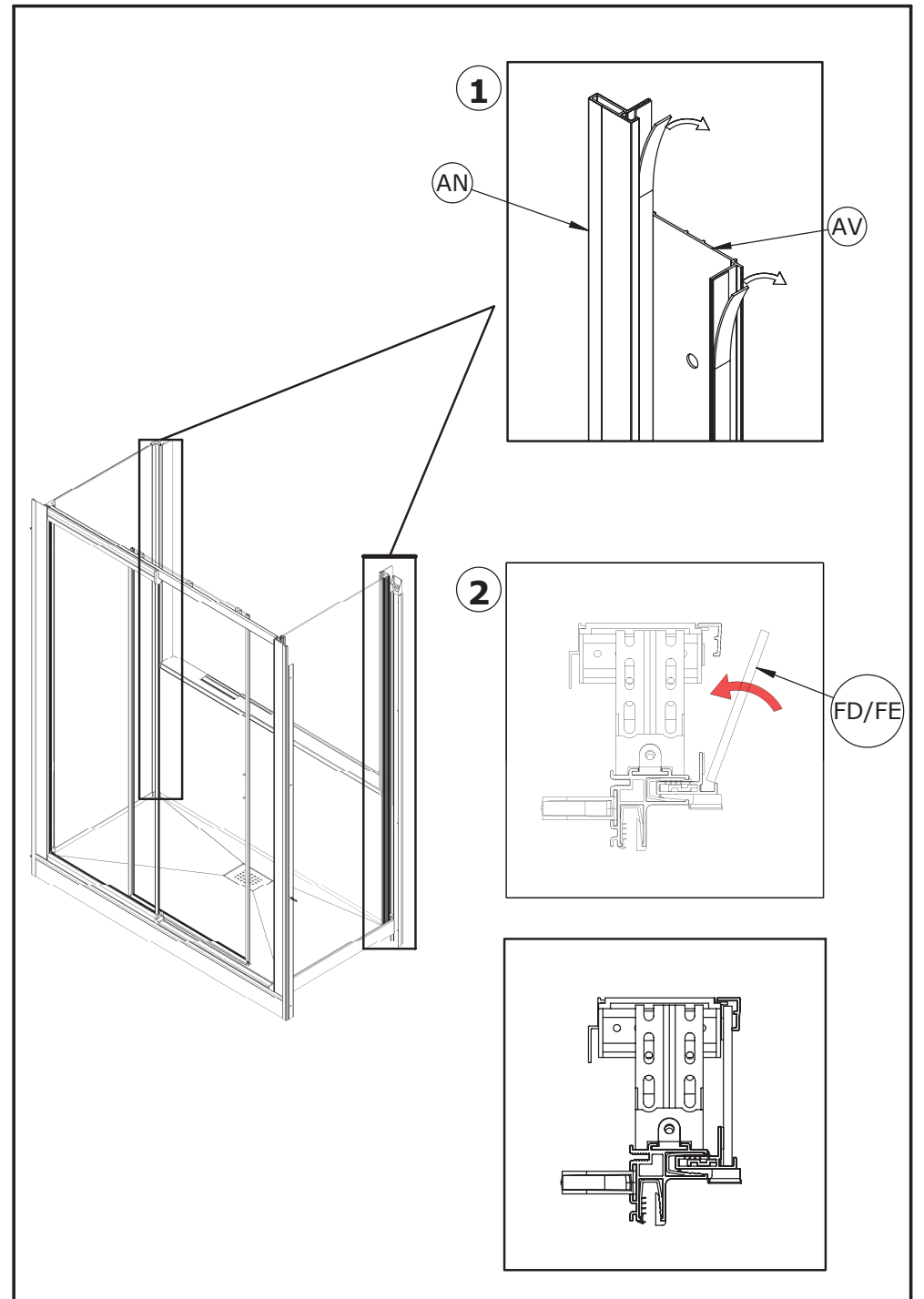
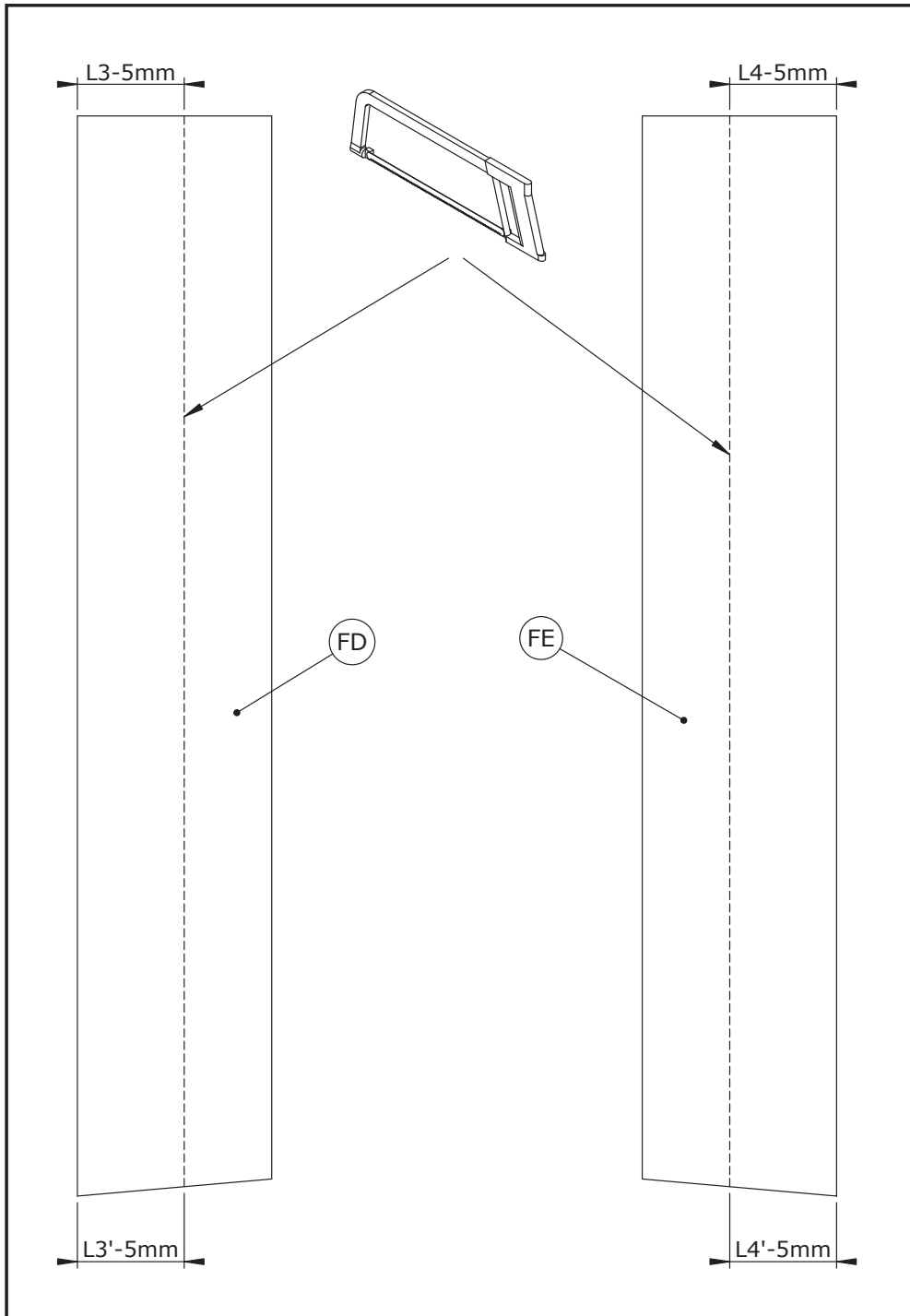

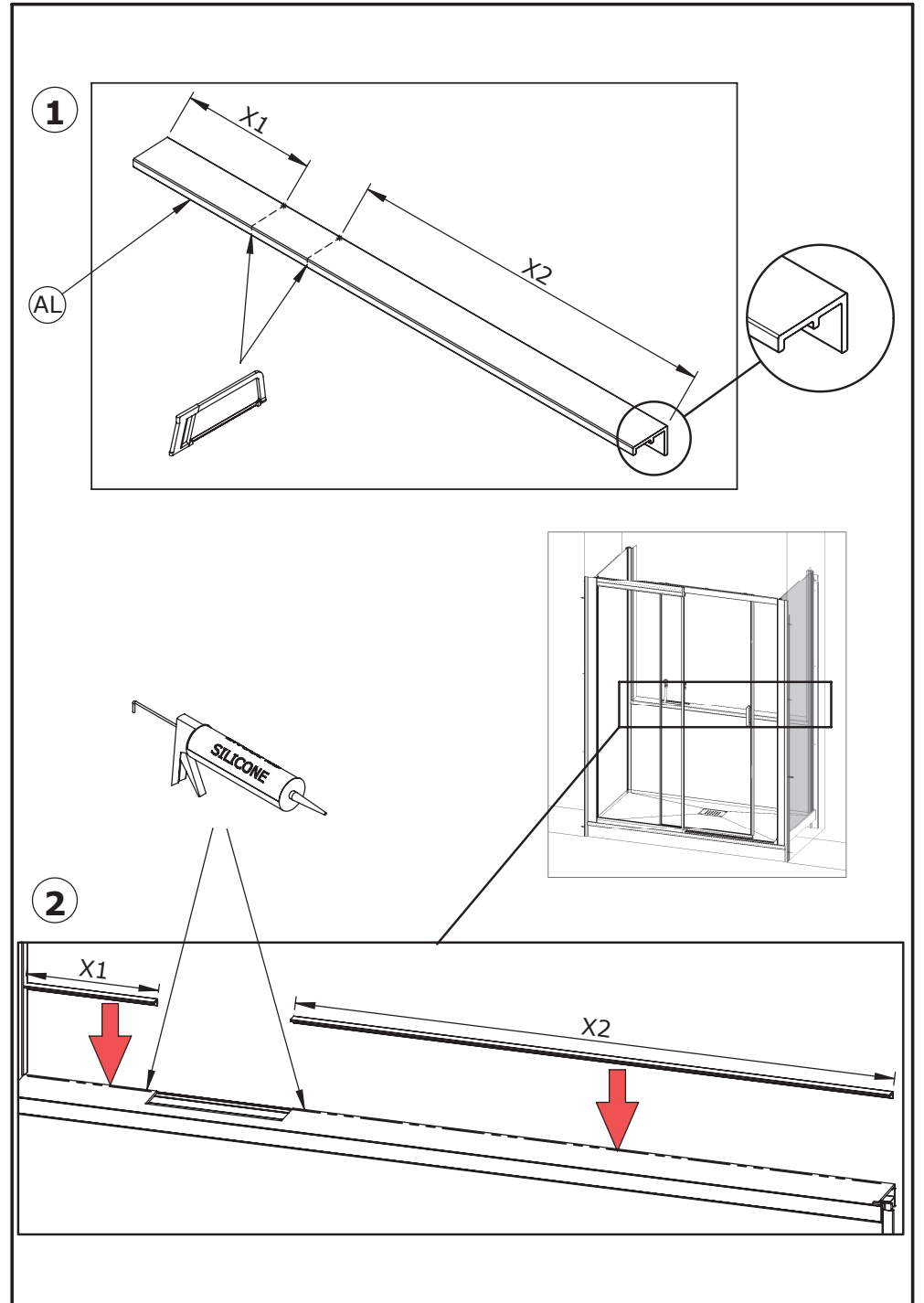
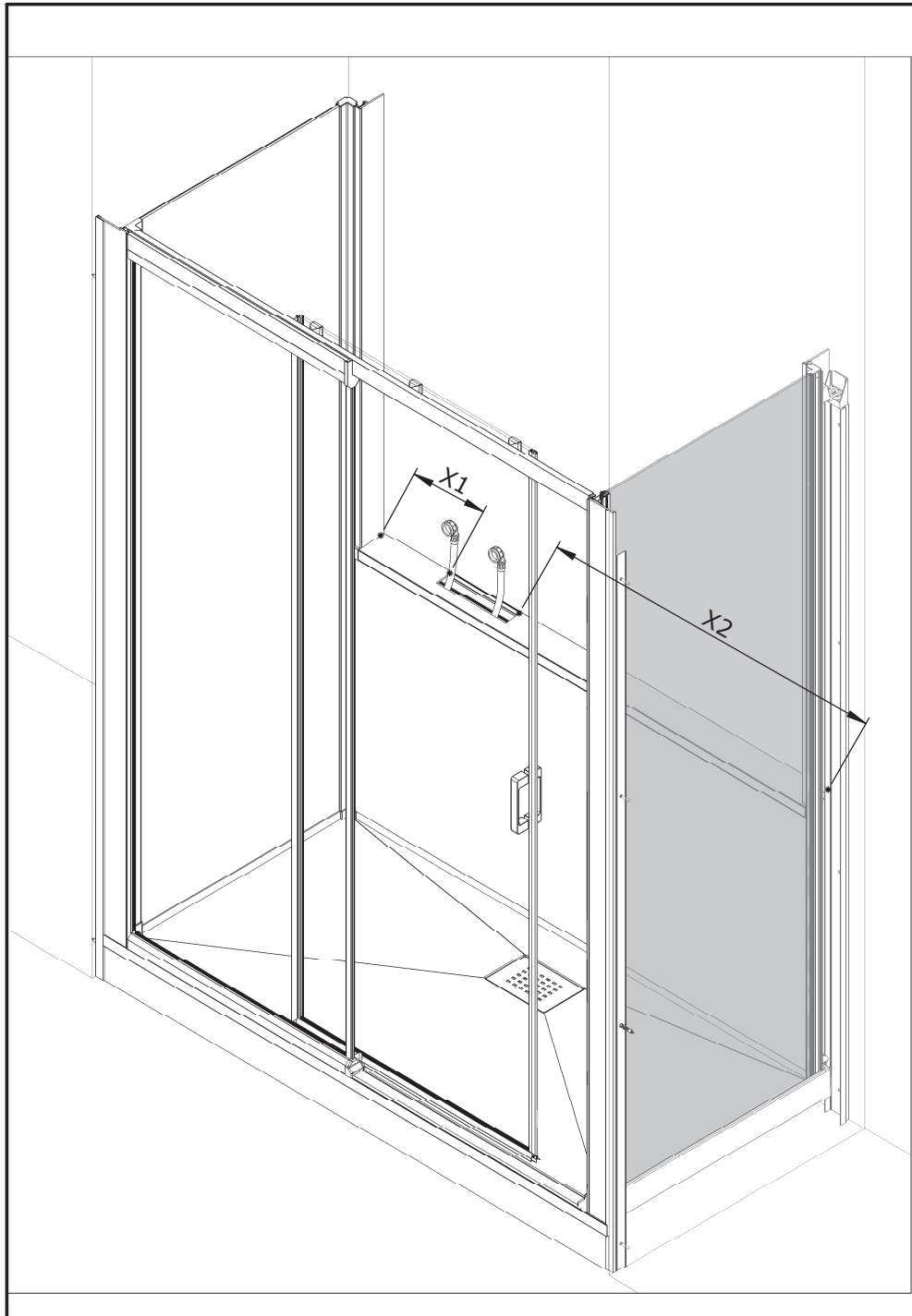

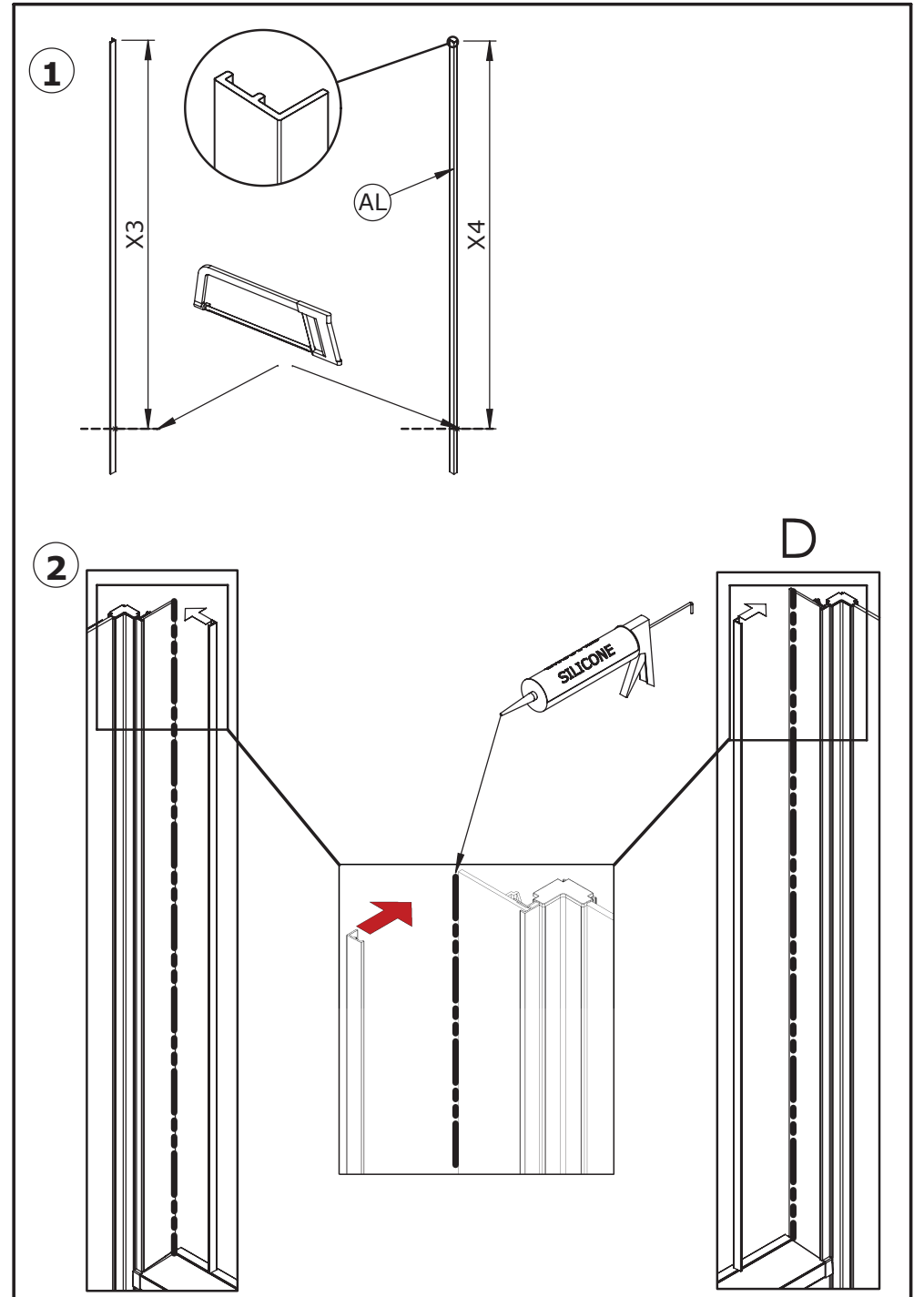
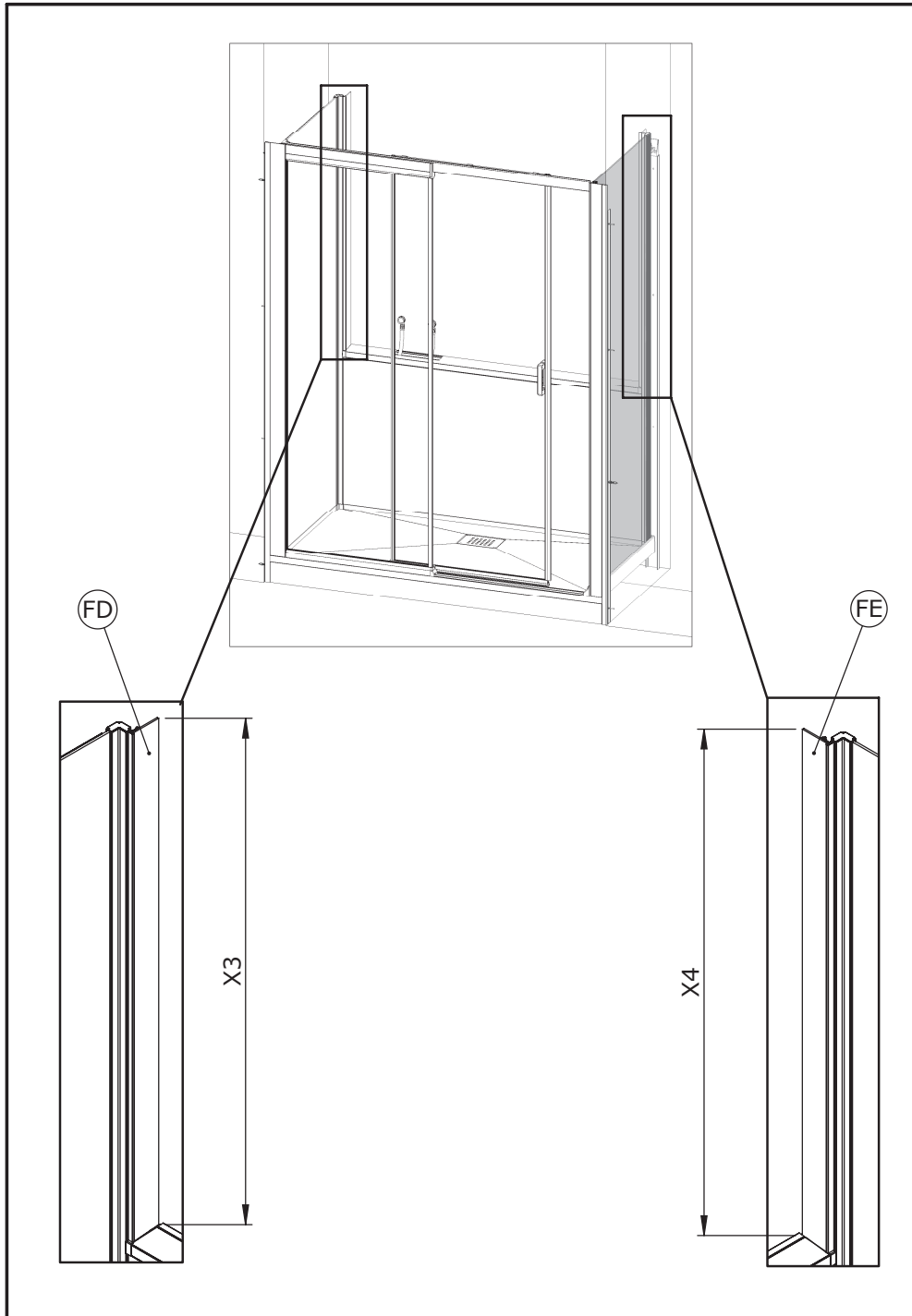

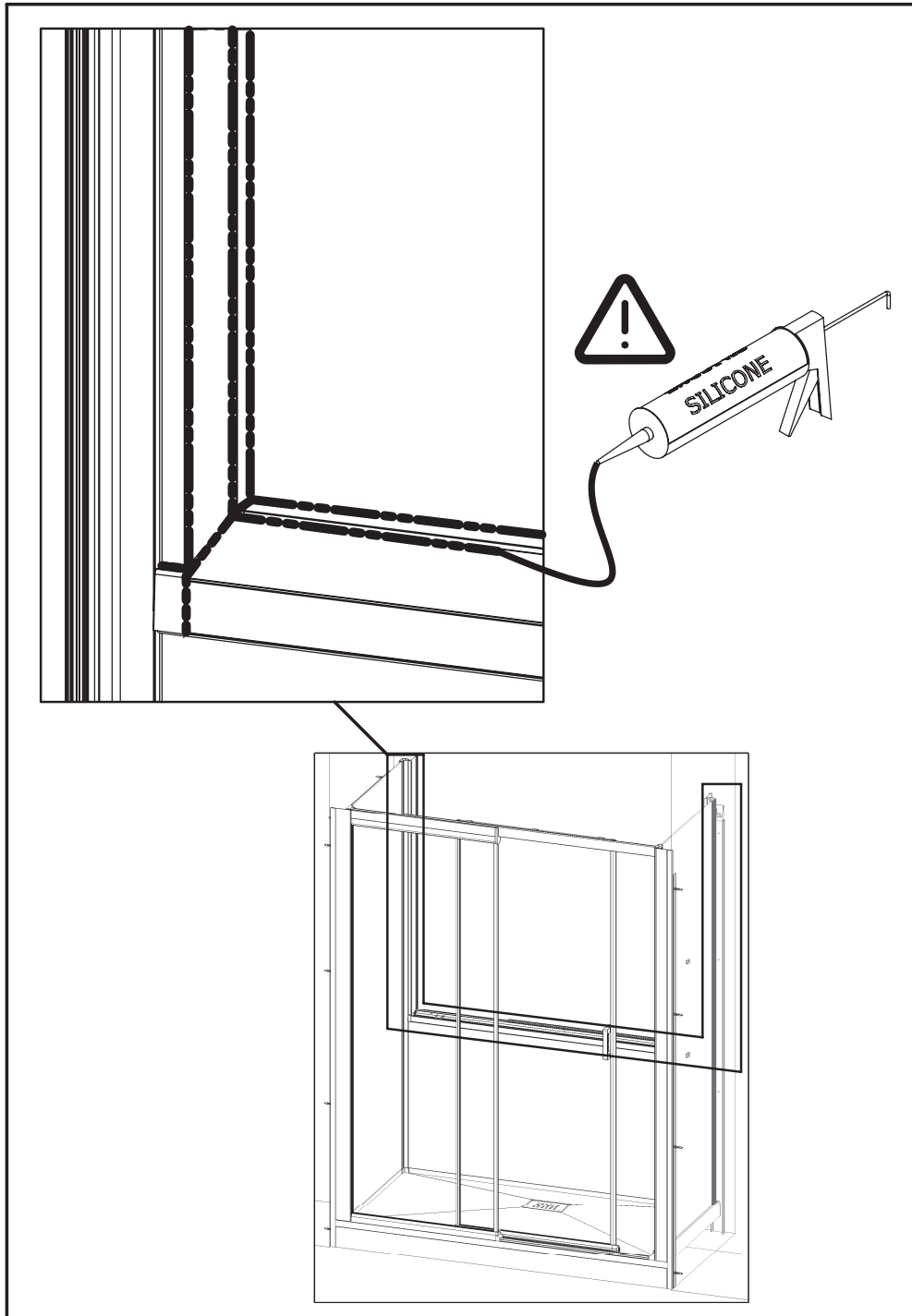



**SERVICE APRÈS-VENTE
AFTER-SALES SERVICE**

FRANCE

+33 (0)2 40 21 29 45

SUISSE/SCHWEIZ

+41 (0)32 631 04 74

UK

+44 (0)20 8842 0033

ESPAÑA

+34 93 544 60 76

IRELAND

+353 04697 33102

NEDERLAND

+31 475 487 100

DEUTSCHLAND

+49 (0) 6074 / 30928 0

BELGIQUE/BELGIË

+31 475 487 100

ITALIA

+39 02 30559420

РОССИЯ

+7 495 258-29-51

ÖSTEREICH

+43 1 710 60 70

PORTUGAL

+351 219 112 785