

# Kinedo

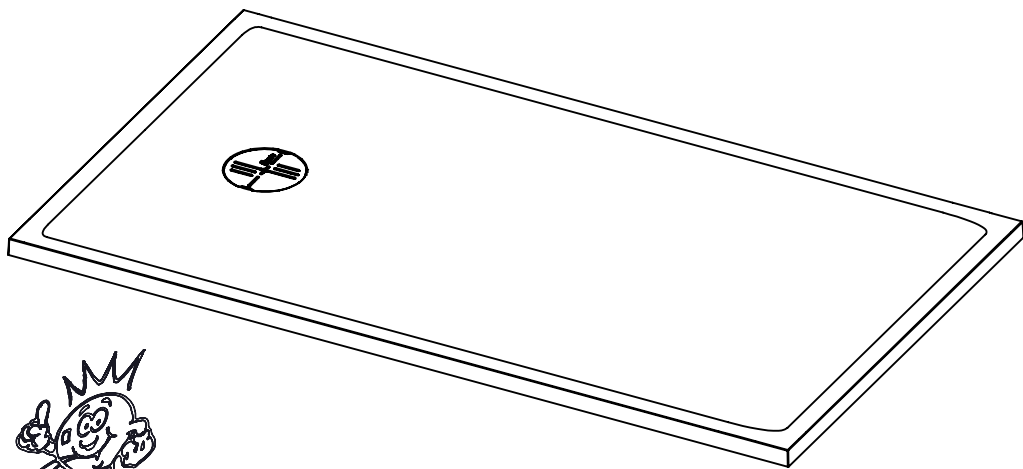

Notre service technique est  
à votre écoute aux numéros  
qui sont au dos de cette  
notice d'installation

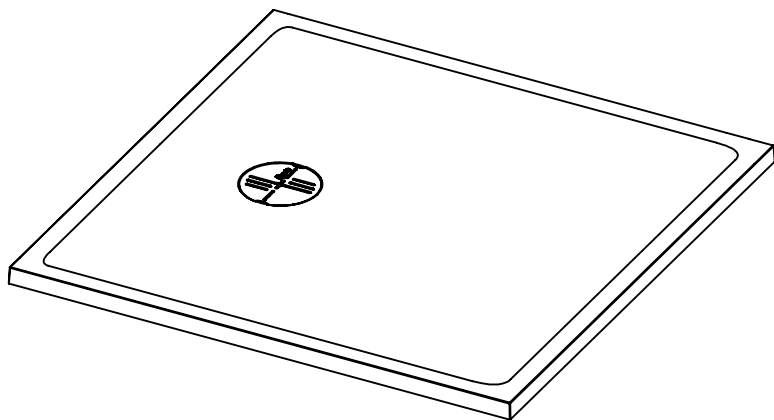
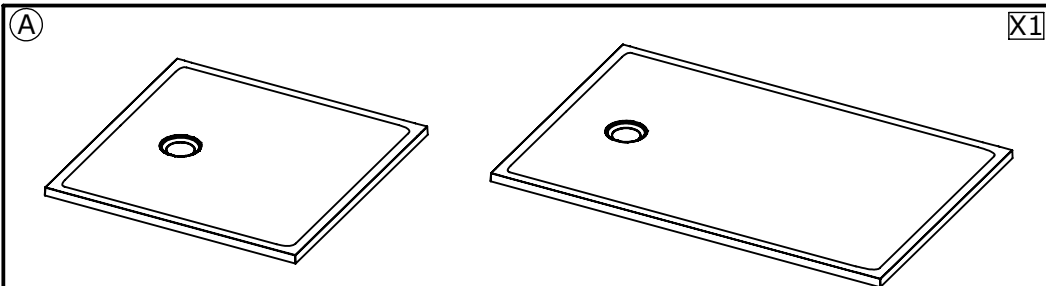

80X80	90X90							
100X70	100X80	100X90	120X70	120X80	120X90			
140X70	140X80	140X90	160X80	160X90				
170X70	180X80	180X90						

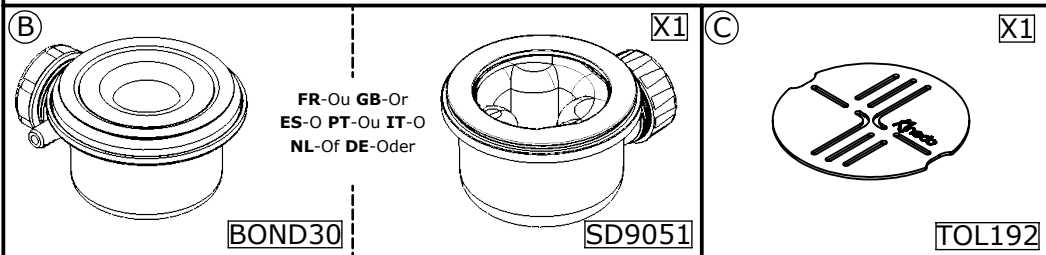

**FR**-Les quantités données sont les quantités utiles au montage. les sachets fournis contiennent des pièces supplémentaires.  
**GB**-The quantities given are what are required for the installation. There may be some surplus in the package provide.  
**ES**-Las cantidades indicadas son las cantidades necesarias para el montaje. Las bolsitas incluidas contienen piezas suplementarias.  
**PT**- A quantidade indicada é a quantidade necessária para montagem. As bolsas incluem peças adicionais.  
**IT**-Le quantità fornite sono le quantità necessarie al montaggio. I sacchetti forniti contengono pezzi supplementari.  
**NL**-De aangegeven aantallen zijn bestemd voor de montage. De bijgeleverde zakjes bevatten extra onderdelen  
**DE**-Die Mengenangaben beziehen sich auf die für die Montage benötigten Teile. Es kann eine gewisse Überzahl an Teilen in der Packung vorhanden sein.

**FR-Matériel nécessaire GB-Tools required**  
**ES-Material necesario PT-Equipamento necessário**  
**IT-Materiale necessario NL-Benodigdheden DE-Erforderliche Werkzeuge**

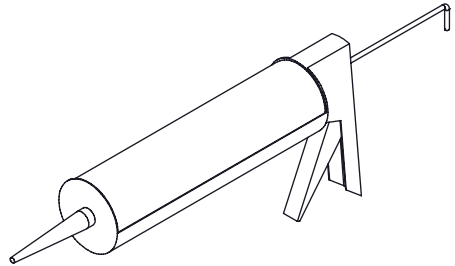
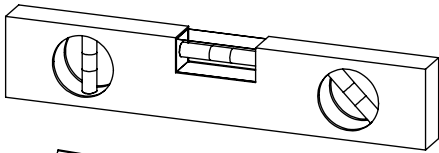

**FR-Colle polyuréthane ou MS polymère**  
**GB-Polyurethane adhesive or MS polymer**  
**ES-Pegamento poliuretano o polímero MS**  
**PT-Cola poliuretano ou polímero**  
**IT-Colla poliuretano o MS polimero**  
**NL-Polyurethaan of MS-polymeer lijm**  
**DE-Polyurethan oder MS-Polymer**  
 Montagekleber verwenden

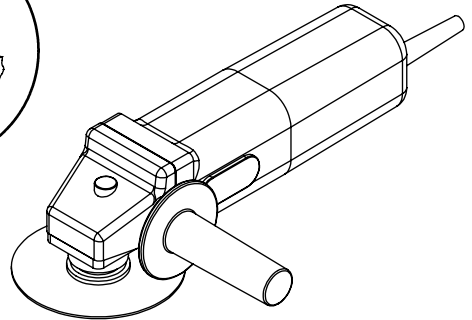
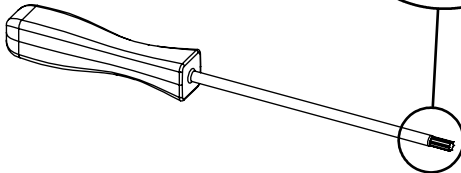
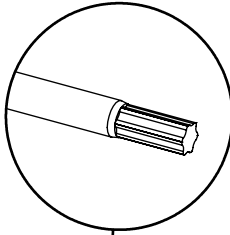
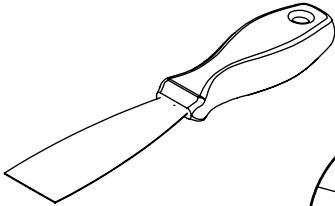

**FR-Meuleuse avec lame diamant Ø230mm min.**  
**GB-Grinder with diamond blade Ø230mm min.**  
**ES-Pulidora con disco de diamante Ø230mm min.**  
**PT-Rebarbadora com disco de diamante Ø230mm min.**  
**IT-Mola con lama diamantata Ø230mm min.**  
**NL-Diamantslijpschijf Ø230mm min.**  
**DE-Winkelschleifer mit Diamanttrennscheibe Ø230mm min.**



**FR**-DECOUPE OPTIONNELLE DU RECEVEUR **GB**-ZONE AVAILABLE FOR OPTIONAL RECUTTING  
**ES**-CORTE OPCIONAL **PT**-RECORTE OPCIONAL  
**IT**-TAGLIO OPZIONALE DEL PIATTO **NL**-ZAGEN VAN DE DOUCHEBAK, OPTINEEL  
**DE**-OPTIONALE SCHNEIDBEREICHE DER DUSCHWANNE

5cm 80x80/90x90  
 100x70/100x80/100x90  
 120x70/120x80/120x90  
 140x70/140x80/140x90

10cm 160x80/160x90/170x70  
 180x80/180x90

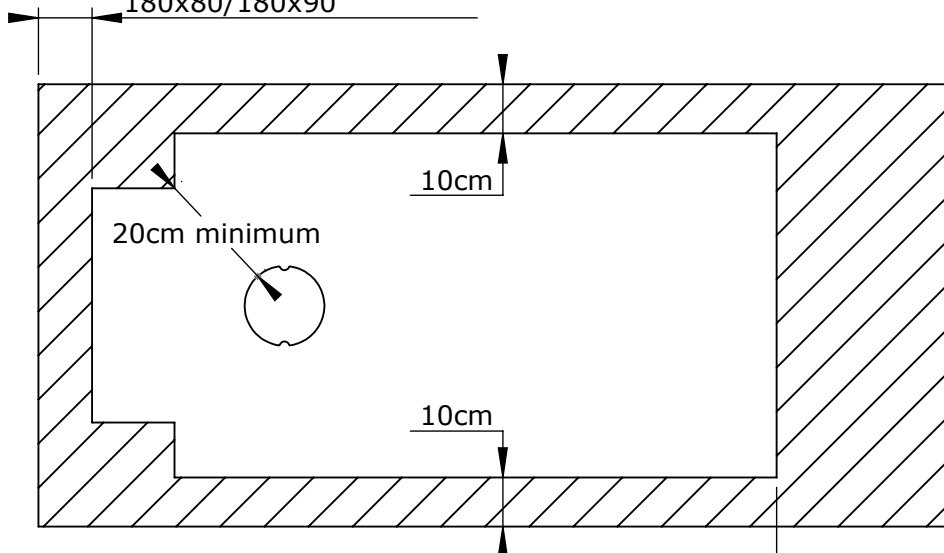

15cm 80x80/90x90  
 100x70/100x80/100x90

20cm 120x70/120x80/120x90

30cm 140x70/140x80/140x90  
 160x80/160x90/170x70  
 180x80/180x90

**FR**-Zone MAXI découpable  
**GB**-MAX cuttable area  
**ES**-Zona maxjma de recorte  
**PT**-Limite MAXIMO de corte  
**IT**-Limite MASSIMO di taglio  
**NL**-MAXIMAAL aanpasbaar deel  
**DE**-MAXIMALER Schneidbereich

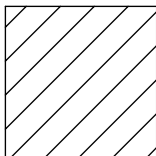

1

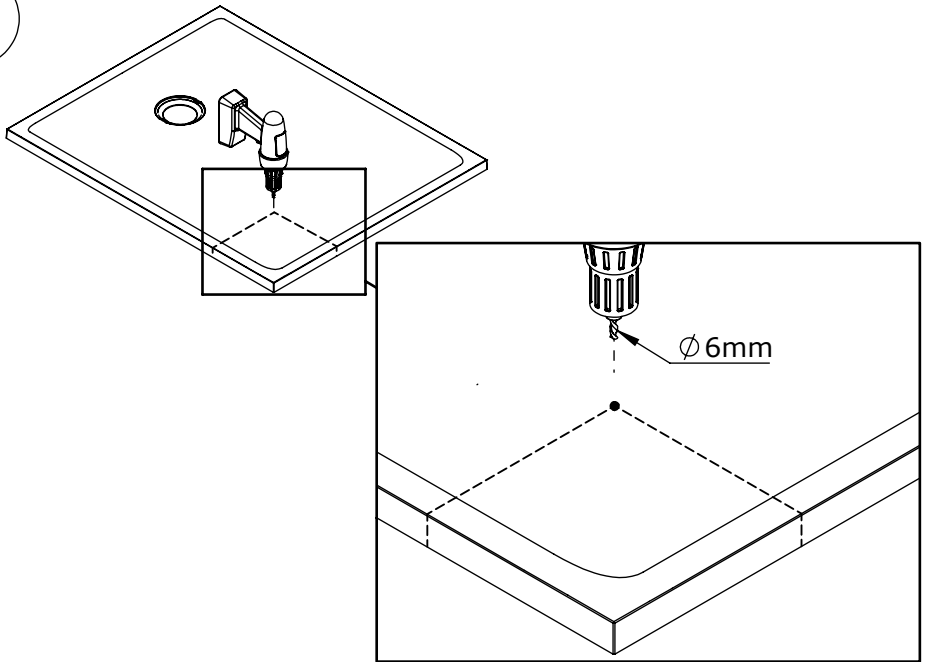

2

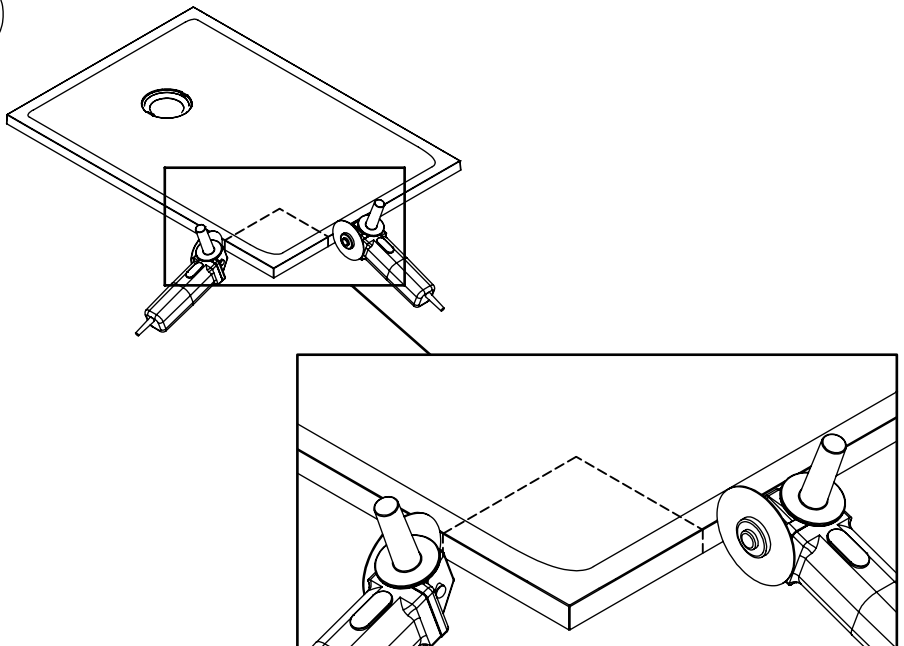

3



**FR**-Appliquer une couche de colle polyuréthane ou MS polymère à l'aide d'une spatule sur la surface coupée

et combler l'espace entre les nervures du receveur avec une couche de mortier adhésif.

**GB**-Apply a polyurethan adhesive or MS polymer layer using a spatula over the raw surface and fill the space

between the ribs of the tray with a layer of adhesive mortar.

**ES**-Aplicar una capa de pegamento poliuretano o polímero MS en la superficie recortada. Puede ayudarse de

una espátula y rellenar los espacios huecos del plato con una capa de mortero adhesivo.

**PT**-Aplique uma camada de cola de poliuretano ou polímero MS na superfície cortada com uma espátula e preencha o espaço vazio da base com uma camada de argamassa selante.

**IT**-Applicare della colla poliuretana o MS polimero con l'aiuto di una spatola sulla parte tagliato e

compensare lo spazio tra le venature del piatto con uno strato di materiale adesivo.

**NL**-Breng met een spatel een laag polyurethaan lijm of MS polymeer lijm aan op de zaagranden, en vul de

tussenliggende ruimte tot het steunoppervlak van de douchebak op met een laag cement.

**DE**-Wenn Sie ihre Duschtasse zuschneiden, müssen die Schnittkanten mittels Polyurethan- oder MS-Polymer-Klebstoff versiegelt werden.

Tragen Sie die Versiegelung mit einem Spachtel auf der Schnittfläche auf und füllen Sie den Duschwannenuntergrund im Zuschnittbereich mit dem Klebstoff zur Stabilisierung auf.

**FR**-Colle polyuréthane/MS polymère

**GB**-Polyurethane adhesive/MS polymer

**ES**-Pegamento poliuretano/polímero MS

**PT**-Cola poliuretano ou polímero

**IT**-Colla poliuretana/MS polimero

**NL**-Polyurethaan/MS polymeer lijm

**DE**-Schicht aus Polyurethan-/MS-Polymer-Klebstoff

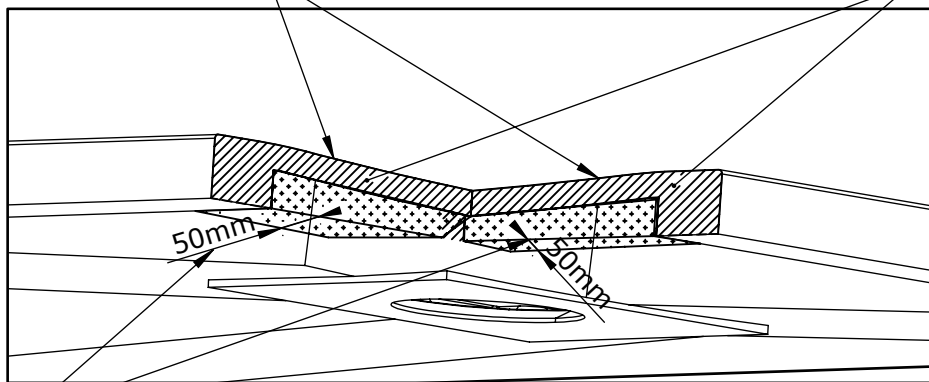

**FR**-Couche de 50mm de mortier adhésif **GB**-50mm layer of adhesive mortar

**ES**-Capa de 50mm de grosor de mortero adhesivo

**PT**-Camada de 50mm de argamassa selante

**IT**-Strato di 50mm di materiale adesivo

**NL**-Laag van 50mm lijm mortel **DE**-50mm x Schnittlänge mit Klebstoff auffüllen

**FR**-Nombre de pieds **GB**-Feet quantity **ES**-Cantidad de pies **PT**-número de pés  
**IT**-Quantità di piedini **NL**-Hoeveelheid voeten **DE**-Anzahl an FüÙe

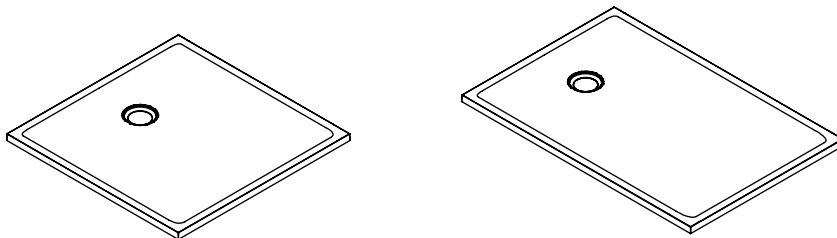

80X80	5	90X90	5	100X70	5	100X80	5	100X90	5	120X70	6	120X80	6	120X90	6
140X70	6	140X80	6	140X90	6	160X80	6	160X90	8	170X170	6	180X80	7	180X90	9

**FR**-La distance bord à bord entre deux pieds ne doit pas être de plus de 30 cm.  
 LES PIEDS DOIVENT ETRE INSTALLES SUR LES NERVURES DU RECEVEUR.

**GB**-The distance from the edge of the shower tray to the edge of a peripheral support should be no more than 30 cm.

THE FEET MUST BE INSTALLED ON THE SHOWER TRAY RIBS.

**ES**-La distancia entre cada pie no debe superar los 30 cm.

LOS PIES DEBEN ESTAR INSTALADOS SIGUIENDO LAS NERVIOS DEL PLATO.

**PT**-A distância entre cada pé não deve exceder 30 cm.

OS PÉS DEVEM SER INSTALADOS NAS NERVURAS DA BASE.

**IT**-Ladistanza tra due piedi non dovrebbe essere superiore a 30 cm.

I PIEDI DEVONO ESSERE ISTALLATI SULLE NERVATURE DEL PIATTO DOCCIA.

**NL**-De afstand tussen twee stelpoten mag niet meer dan 30 cm bedragen.

DE STELPOTEN DIENEN OP HET STEUNOPPERVLAK VAN DE DOUCHEBAK GEÏNSTALLEERD TE WORDEN.

**DE**-Der Abstand zwischen zwei verstellbaren FüÙen darf 30 cm nicht überschreiten.

DIE FÜÙE MÜSSEN AUF DEN TRÄGERN DER DUSCHTASSE MONTIERT WERDEN.

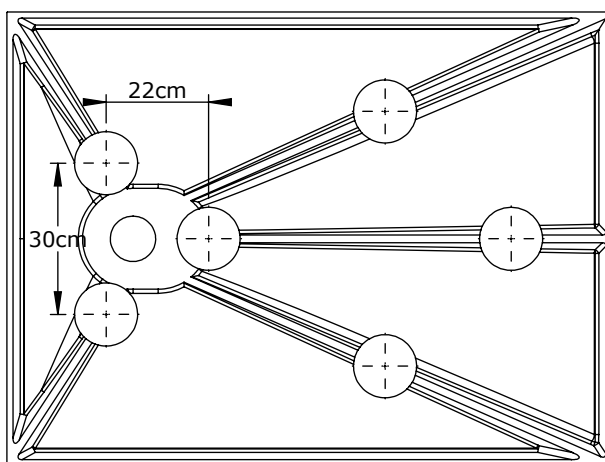

[http://tiny.cc/notice\\_pieds\\_universelle](http://tiny.cc/notice_pieds_universelle)

# FR

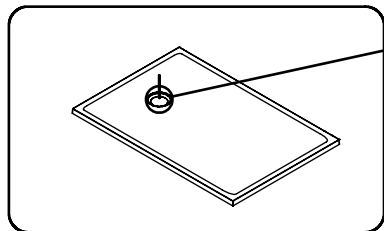

Tracer la position de la bonde et réaliser un montage à blanc de la bonde et du receveur

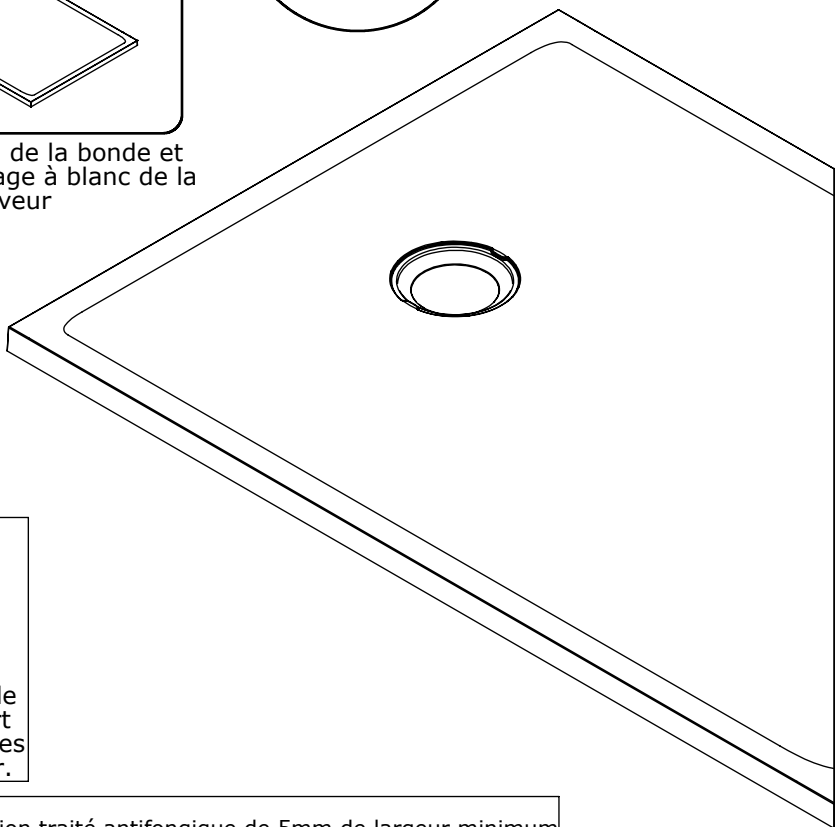

Il est indispensable d'avoir un support imputrescible sur les côtés du receveur.

- ① - silicone de finition traité antifongique de 5mm de largeur minimum
- ② - silicone d'étanchéité souple traité antifongique
- ③ - élément de soutien du joint silicone
- ④ - silicone d'appui
- ⑤ - colle polyuréthane ou MS polymère

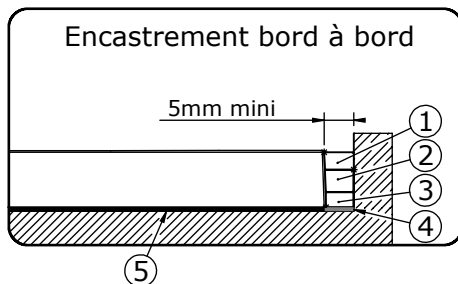
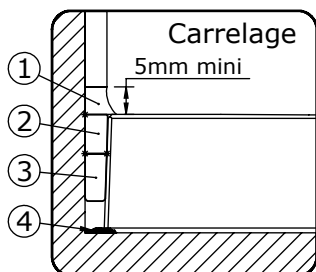





Pendant toute la durée des travaux, protéger le receveur contre toute agression : brûlures, chocs, rayures, décapants...



Le montage d'une soupape anti-vide est nécessaire pour une utilisation optimale si un autre appareil sanitaire est raccordé sur la même évacuation.

Ne pas utiliser d'acide chlorhydrique ni de dégraissant puissant

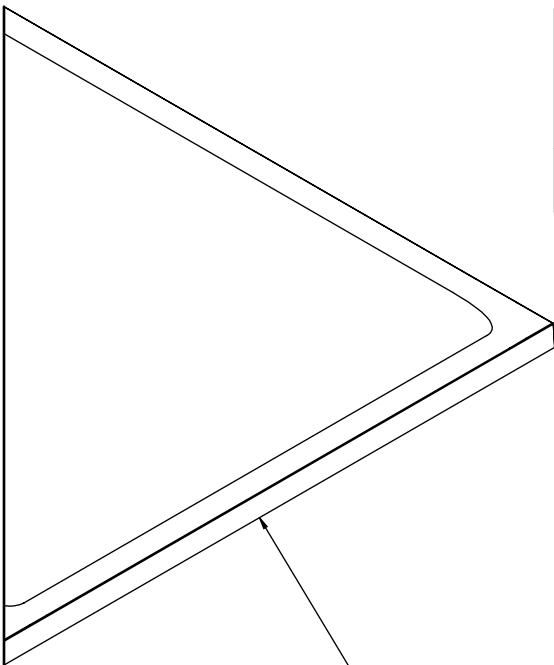

Sol rigide indispensable

Pose directe au sol

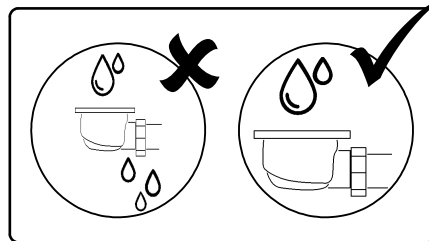
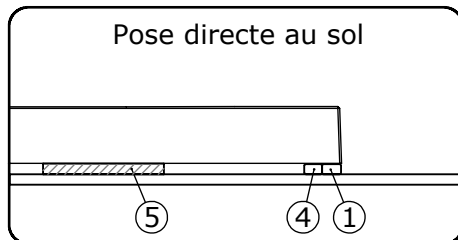

En butée contre le carrelage

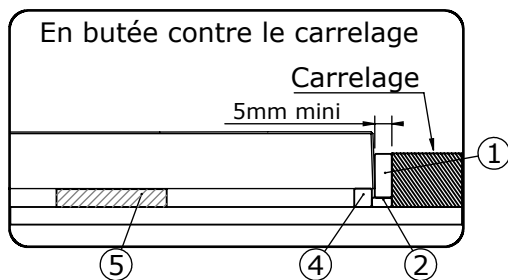

# TYPES D'INSTALLATIONS KINEMOON EVO

## CARRÉ ET RECTANGULAIRE

Posé sur pieds réglables avec habillage carrelé

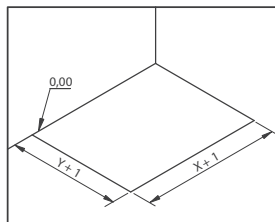
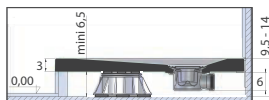
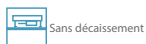

Préparation de l'implantation

X	Y	C	D
80	80	27,5	12,5
90	90	32,5	12,5
100	70	22,5	12,5
100	80	27,5	12,5
100	90	32,5	12,5
120	70	22,5	12,5
120	80	27,5	12,5
120	90	32,5	12,5
140	70	22,5	12,5
140	80	27,5	12,5
140	90	32,5	12,5
160	80	27,5	22,5
160	90	32,5	22,5
170	70	22,5	22,5
180	80	27,5	22,5
180	90	32,5	22,5

Posé en butée contre le carrelage

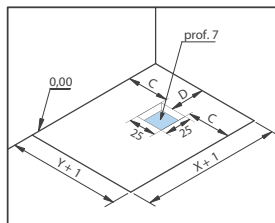
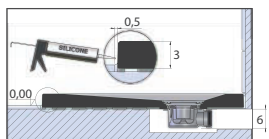
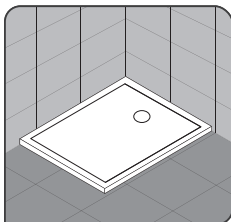

Préparation de l'implantation

Encastré et posé sur pieds réglables

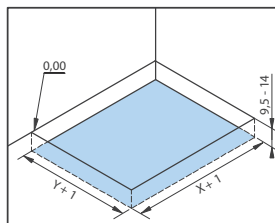
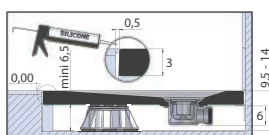

Préparation de l'implantation

Encastré et posé sans pieds réglables

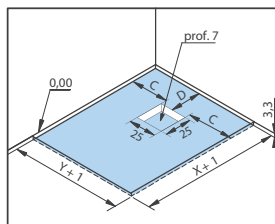
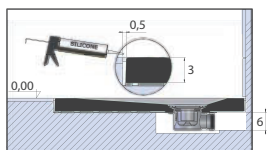
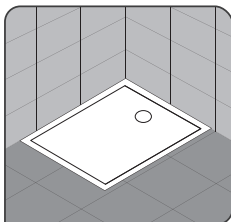

Préparation de l'implantation



# GB

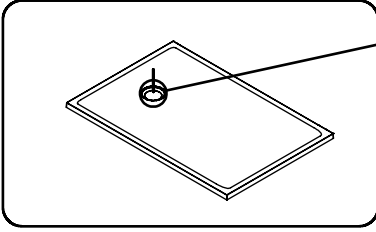

Mark the position of the waste and test-assemble the tray and waste

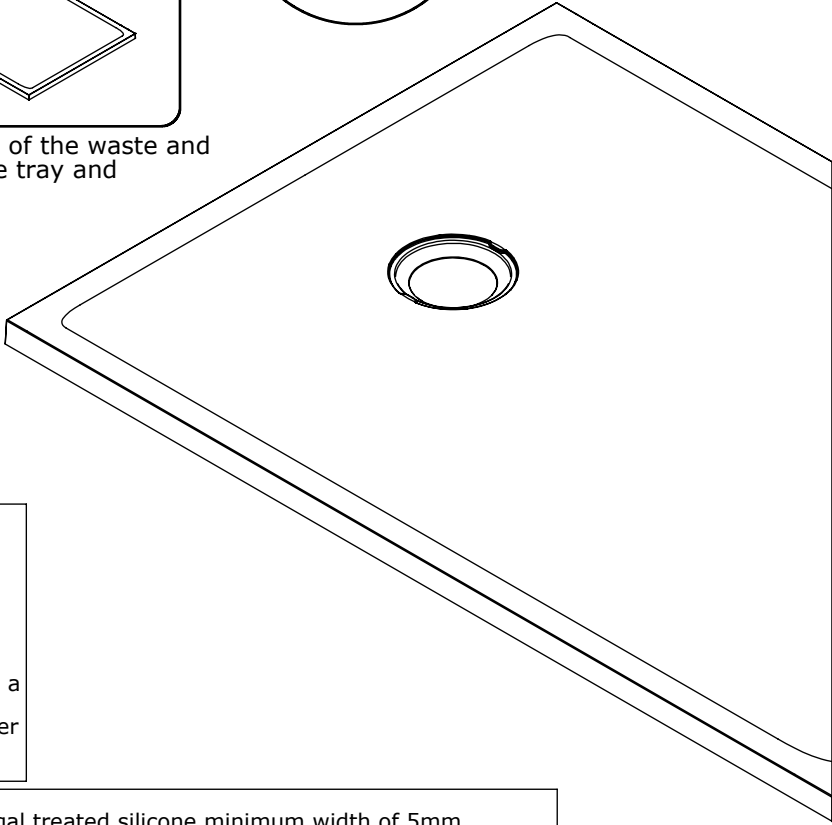

It's essential to have a rigid support on all sides of the shower tray

- ① - finishing antifungal treated silicone minimum width of 5mm
- ② - flexible sealing silicone treated antifungal
- ③ - support Element silicone seal
- ④ - silicone support
- ⑤ - polyurethane adhesive or MS polymer

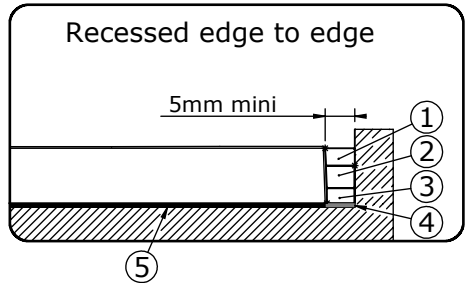
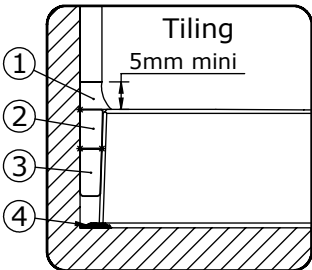



Throughout the duration of the installation, protect the recipient against any scratches, burns, shocks etc



The installation of an anti-vacuum valve is necessary for optimal use if another appliance is connected to the same discharge pipe

Do not use hydrochloric acid or powerful degreaser

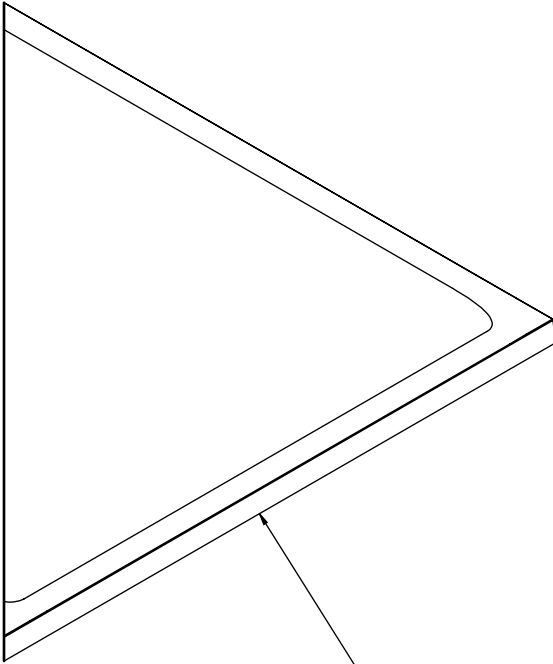

The base must be rigid, flat and dry

### Direct floor installation

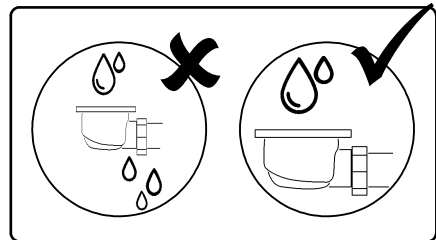
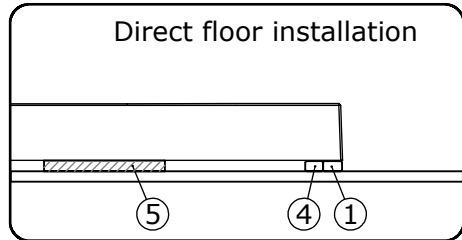

### Abutting against the tile

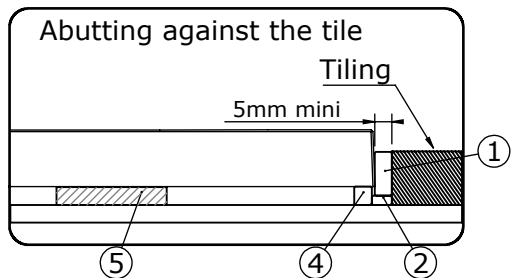

# INSTALLATIONS TYPES KINEMOON EVO

## SQUARE AND RECTANGULAR

Mounted on adjustable legs with tiled cladding

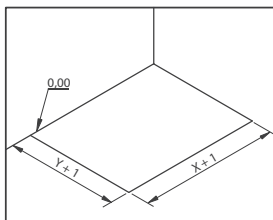
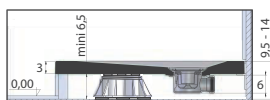
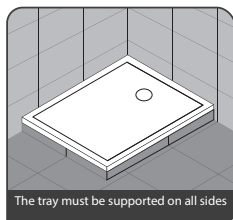

Pre-installation

X	Y	C	D
80	80	27,5	12,5
90	90	32,5	12,5
100	70	22,5	12,5
100	80	27,5	12,5
100	90	32,5	12,5
120	70	22,5	12,5
120	80	27,5	12,5
120	90	32,5	12,5
140	70	22,5	12,5
140	80	27,5	12,5
140	90	32,5	12,5
160	80	27,5	22,5
160	90	32,5	22,5
170	70	22,5	22,5
180	80	27,5	22,5
180	90	32,5	22,5

Installed in abutment against the tile

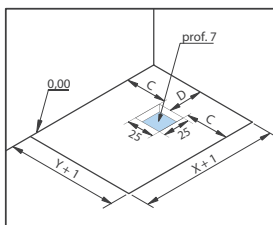
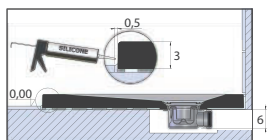
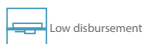
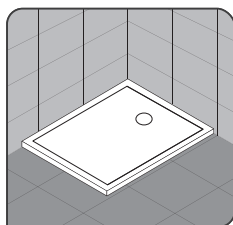

Pre-installation

Built-in and installed on adjustable feet

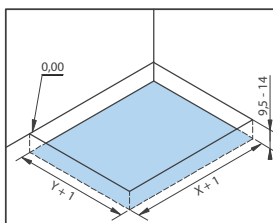
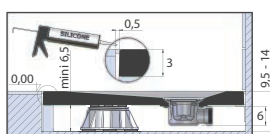
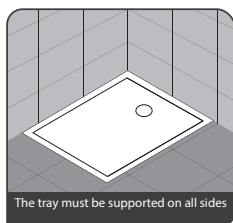

Pre-installation

Built-in and installed without adjustable feet

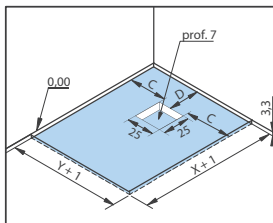
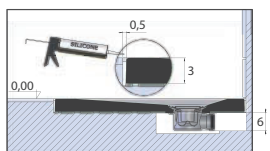
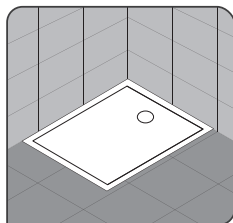

Pre-installation



# ES

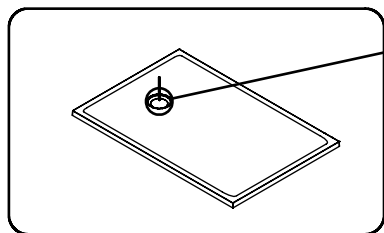

Marcar la ubicación del desagüe y montarlo con el plato para comprobar su correcta ubicación.

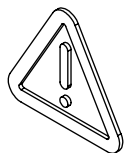
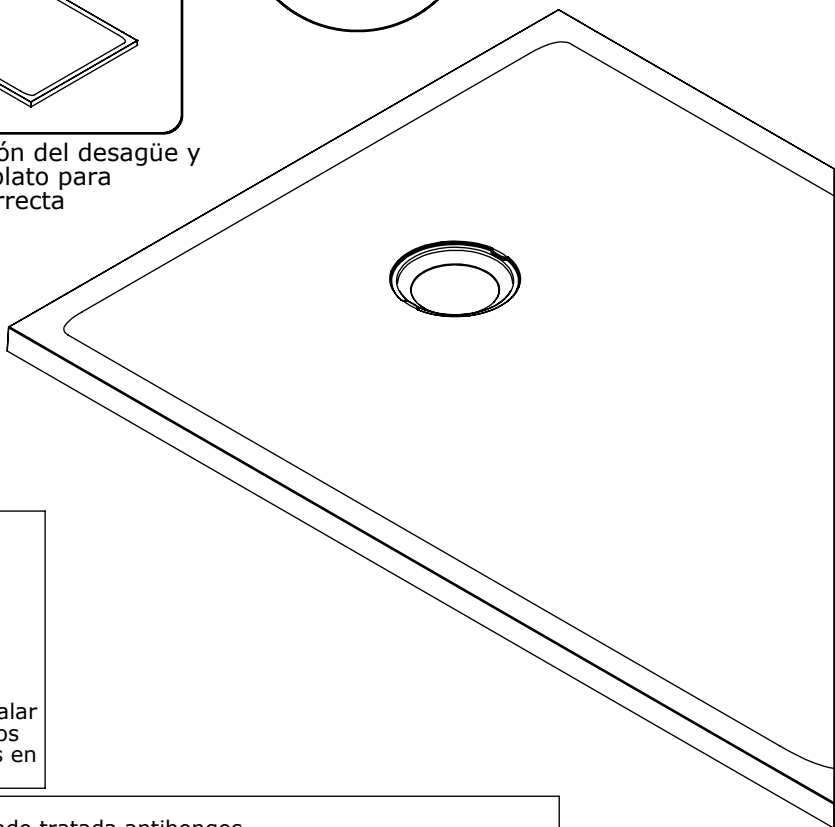

Es imprescindible instalar el plato con productos estancos y antihongos en todos sus lados

- ① - silicona de acabado tratada antihongos
- ② - silicona de estanqueidad, blanda, tratada antihongos
- ③ - soporte de la junta de silicona
- ④ - silicona de apoyo
- ⑤ - pegamento poliuretano o polímero MS

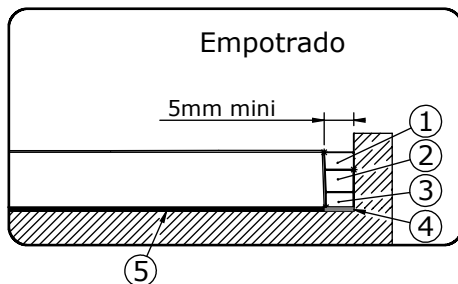
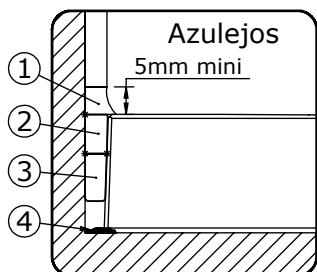





Durante las obras proteger el plato de golpes, quemaduras, rayaduras, etc...



Durante las obras proteger el plato de golpes, quemaduras, rayaduras, etc...

No utilizar ácido clorhídrico o desengrasante potente

Instalación directa al suelo

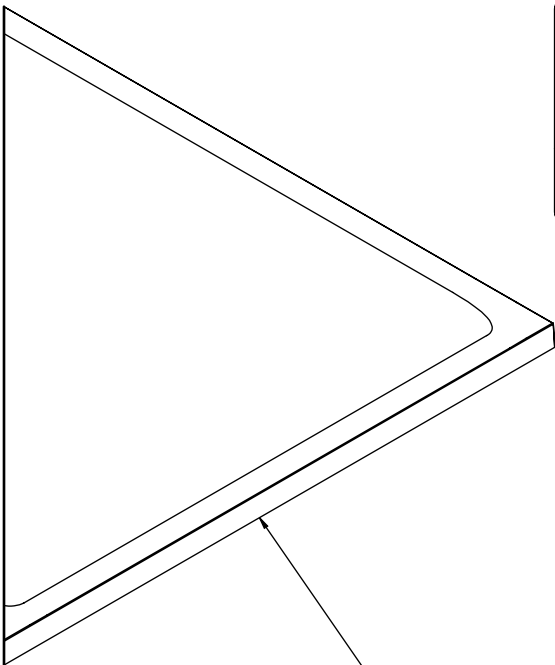
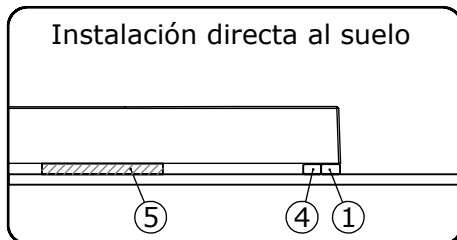

Suelo rígido, plano y seco indispensable

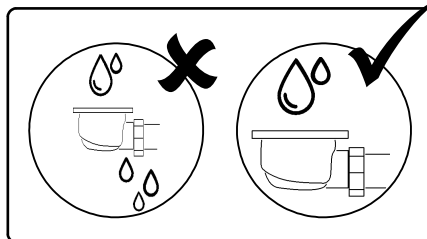

Instalación contra baldosas

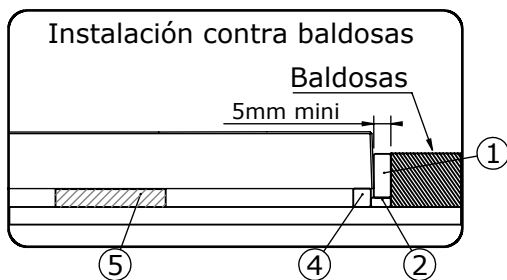

# TIPOS DE INSTALACIÓN KINEMOON EVO

## QUADRADO Y RECTANGULARES

Instalado sobre pies regulables con revestimiento de baldosas

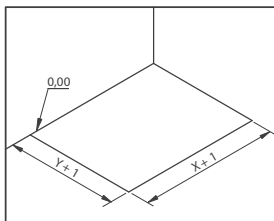
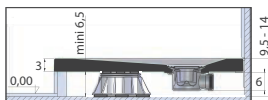

Preparación de la instalación

X	Y	C	D
80	80	27,5	12,5
90	90	32,5	12,5
100	70	22,5	12,5
100	80	27,5	12,5
100	90	32,5	12,5
120	70	22,5	12,5
120	80	27,5	12,5
120	90	32,5	12,5
140	70	22,5	12,5
140	80	27,5	12,5
140	90	32,5	12,5
160	80	27,5	22,5
160	90	32,5	22,5
170	70	22,5	22,5
180	80	27,5	22,5
180	90	32,5	22,5

Instalación directa al suelo

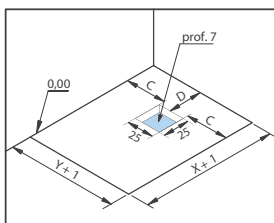
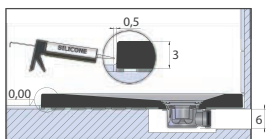
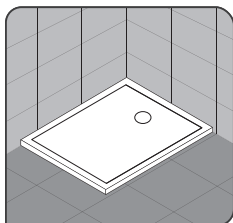

Preparación de la instalación

Instalación a ras de suelo, colocado sobre pies regulables

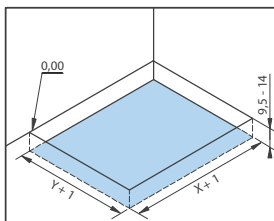
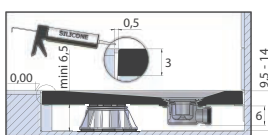

Preparación de la instalación

Instalación a ras de suelo, colocado sin pies regulables

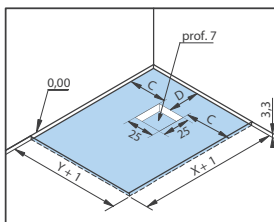
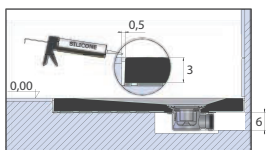
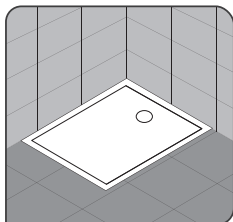

Preparación de la instalación



# PT

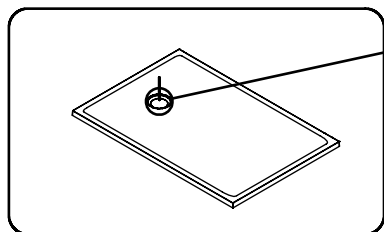

Marcar a localização da válvula e colocar a válvula na base para verificar se a localização é a correta.

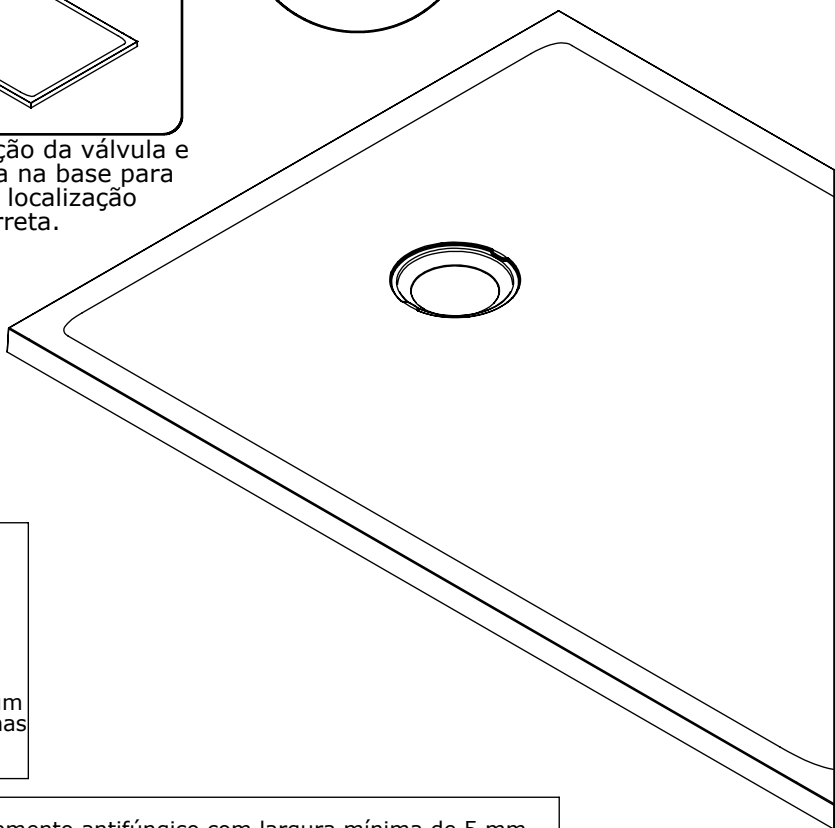

É indispensável ter um apoio imputrescível nas laterais da base.

- ① - silicone de acabamento antifúngico com largura mínima de 5 mm
- ② - selante de silicone macio com tratamento antifúngico
- ③ - elemento de suporte da junta de silicone
- ④ - suporte de silicone
- ⑤ - cola de poliuretano ou MS polímero

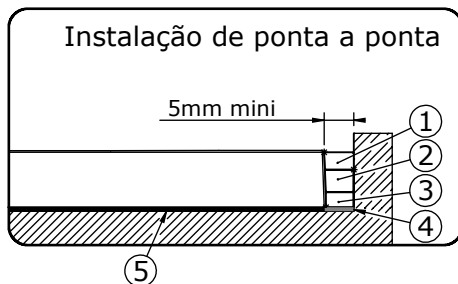
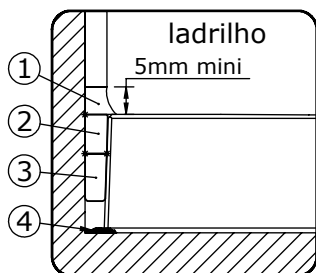



Durante toda a duração da obra, proteger a base de qualquer dano: queimadura, impacto, risco...



Instalar uma válvula anti-vácuo para um bom funcionamento, caso outro elemento sanitário esteja ligado à mesma evacuação.

Não utilizar ácido clorídrico ou desgordurante agressivos

### Instalação direta no chão

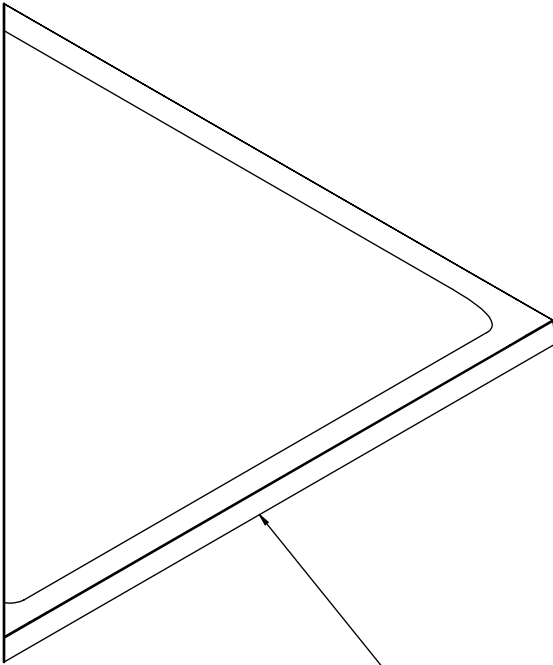
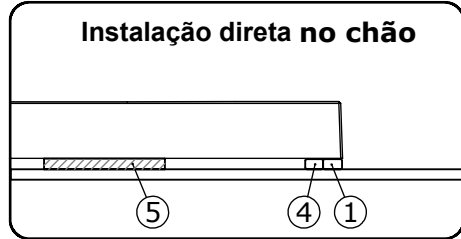

Piso rígido indispensável

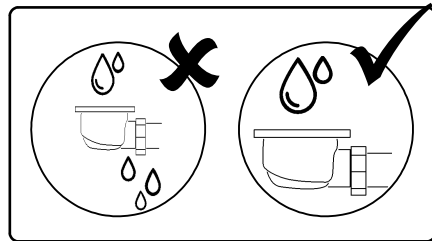

### Encostado ao ladrilho

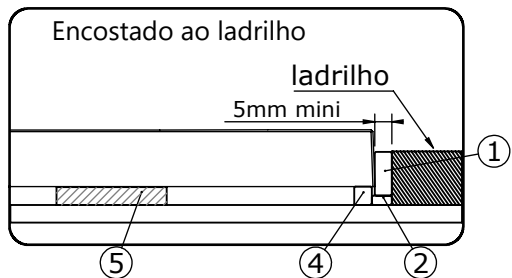

# TIPO DE INSTALAÇÕES KINEMOON EVO

## QUADRADO E RETANGULAR

Instalado em pés ajustáveis com cobertura de azulejo

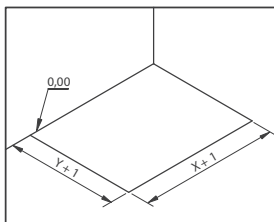
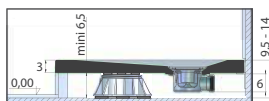

Preparação da instalação

X	Y	C	D
80	80	27,5	12,5
90	90	32,5	12,5
100	70	22,5	12,5
100	80	27,5	12,5
100	90	32,5	12,5
120	70	22,5	12,5
120	80	27,5	12,5
120	90	32,5	12,5
140	70	22,5	12,5
140	80	27,5	12,5
140	90	32,5	12,5
160	80	27,5	22,5
160	90	32,5	22,5
170	70	22,5	22,5
180	80	27,5	22,5
180	90	32,5	22,5

Instalação direta no solo

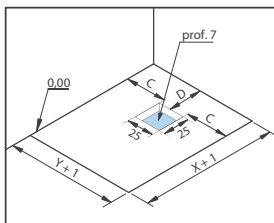
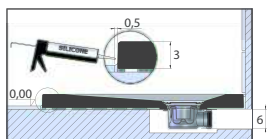
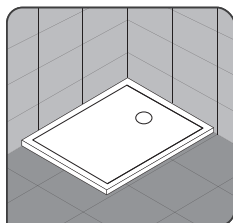

Preparação da instalação

Instalação embutida, sobre pés ajustáveis

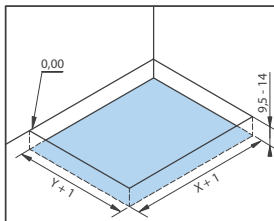
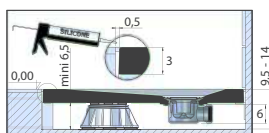

Preparação da instalação

Instalação embutida sem pés ajustáveis

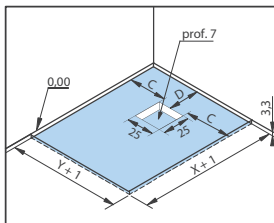
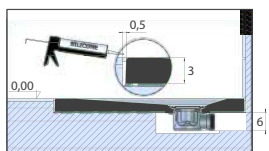
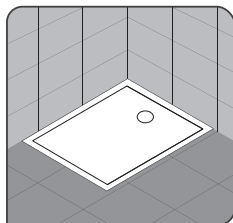

Preparação da instalação



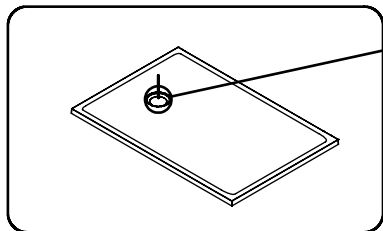

Tracciare la posizione dello scarico e realizzare un montaggio a vuoto dello scarico e del piatto

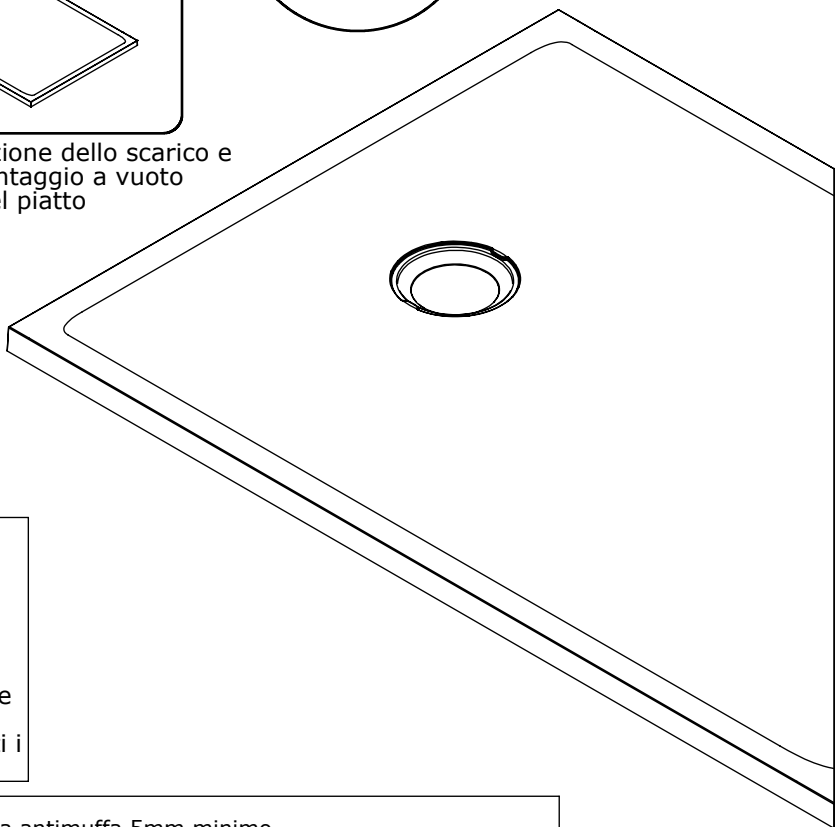

- ① - silicone di finitura antimuffa 5mm minimo
- ② - silicone di tenuta antimuffa
- ③ - elemento di tenuta del silicone
- ④ - supporto in silicone
- ⑤ - colla poliuretanica o MS polimero

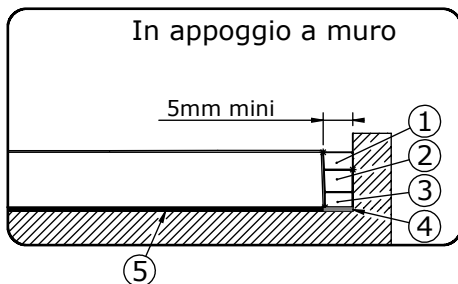
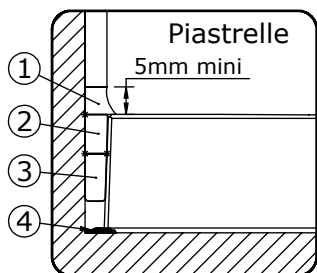





Durante la posa proteggere  
il piatto da graffi, colpi,  
attrezzi, bruciature ...



Il montaggio di una valvola di  
sicurezza è richiesto per un uso  
ottimale se un altre utenze sono  
collegate allo stesso scarico.

Non utilizzare acido cloridrico o forti  
sgrassatori

### Posa diretta al suolo

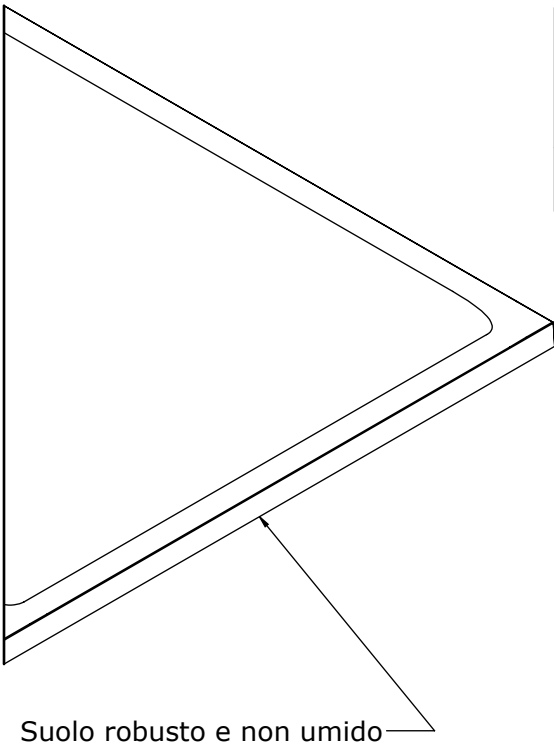
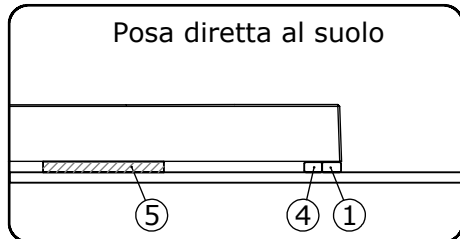

Suolo robusto e non umido

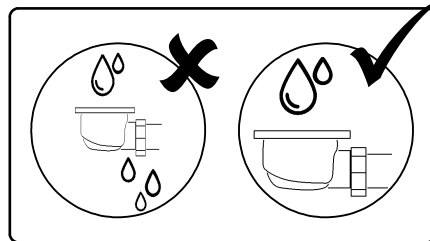

### Battuta contro la piastrella

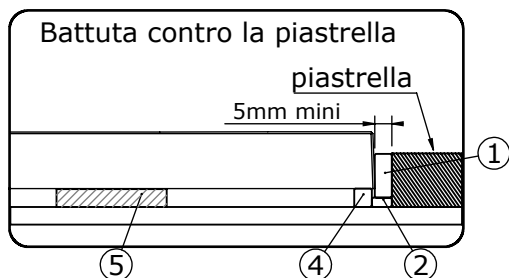

# TIPI DI INSTALLAZIONE DI KINEMOON EVO

## QUADRATO E RETTANGOLARE

Montato su piedini regolabili con rivestimento in piastrelle

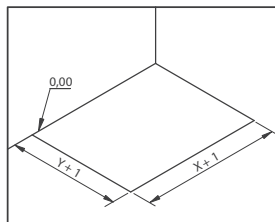
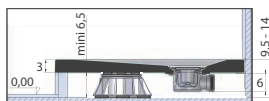

predisposizione impianto

X	Y	C	D
80	80	27,5	12,5
90	90	32,5	12,5
100	70	22,5	12,5
100	80	27,5	12,5
100	90	32,5	12,5
120	70	22,5	12,5
120	80	27,5	12,5
120	90	32,5	12,5
140	70	22,5	12,5
140	80	27,5	12,5
140	90	32,5	12,5
160	80	27,5	22,5
160	90	32,5	22,5
170	70	22,5	22,5
180	80	27,5	22,5
180	90	32,5	22,5

Installato in appoggio a pavimento

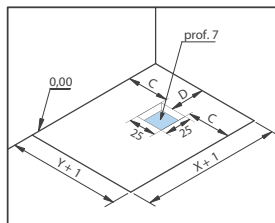
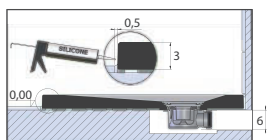
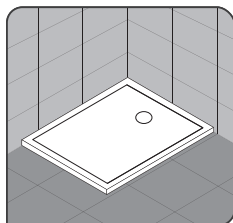

predisposizione impianto

Incassato e posizionato su piedini regolabili

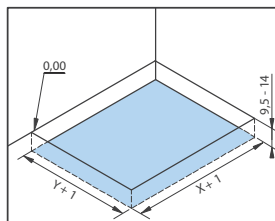
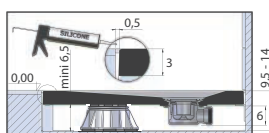

predisposizione impianto

Incassato e posizionato senza piedini regolabili

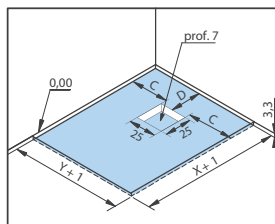
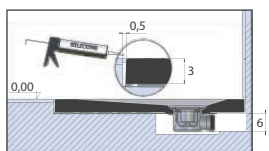
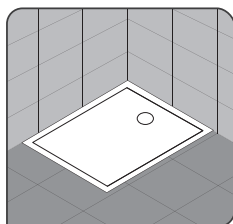

predisposizione impianto



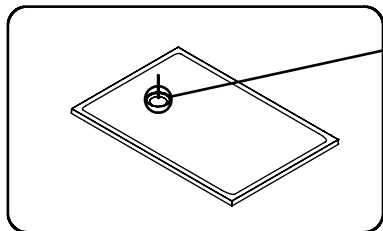

Markeer de positie van de afvoer en situeer de afvoer en de douchebak op de gewenste plaats

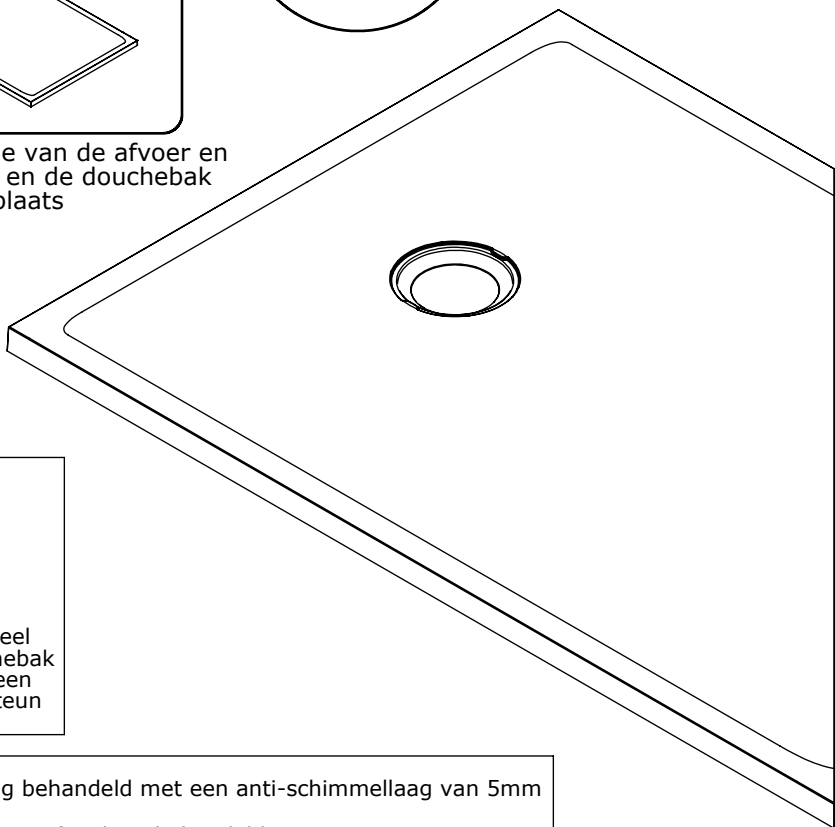

- ① - siliconenafwerking behandeld met een anti-schimmellaag van 5mm mino
- ② - waterdichte siliconenafwerking behandeld met een anti-schimmellaag
- ③ - element ter ondersteuning van de siliconenstrip
- ④ - aanbrengen van siliconenkit
- ⑤ - polyurethaan lijm of MS ployleer

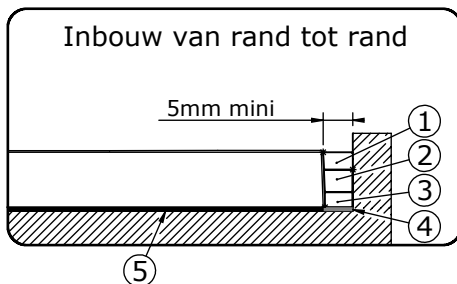
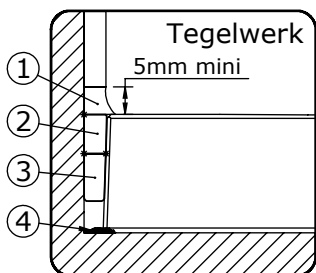



Bescherm de douchebak tijdens de werkzaamheden tegen brandplekken, schokken en beschadigingen door krassen etc...



De Montage van een afdichtingsklep/ventiel is noodzakelijk voor optimaal gebruik indien men een ander sanitair product wil aansluiten op dezelfde afvoer.

Geen chloorhoudende producten en ontvetters gebruiken!

Plaatsing direct op de vloer

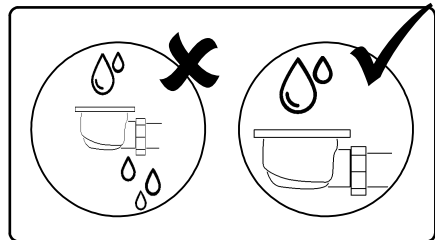
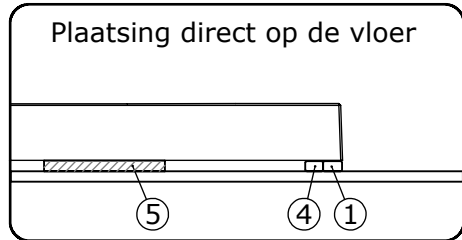

Vlakke niet-vochtige vloer is essentieel

Plaatsing tegen het tegelwerk

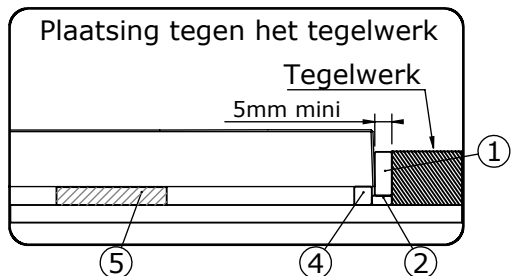

# KINEROCK EVO-INSTALLATIEMOGELIJKHEDEN

## VIERKANT EN RECHTHOEKIG

Geïnstalleerd op in hoogte verstelbare poten en afgewerkt met tegels

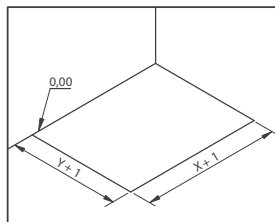
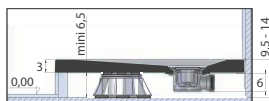

Vorbereitung montage

X	Y	C	D
80	80	27,5	12,5
90	90	32,5	12,5
100	70	22,5	12,5
100	80	27,5	12,5
100	90	32,5	12,5
120	70	22,5	12,5
120	80	27,5	12,5
120	90	32,5	12,5
140	70	22,5	12,5
140	80	27,5	12,5
140	90	32,5	12,5
160	80	27,5	22,5
160	90	32,5	22,5
170	70	22,5	22,5
180	80	27,5	22,5
180	90	32,5	22,5

Geïnstalleerd half verzonken tegen de tegels

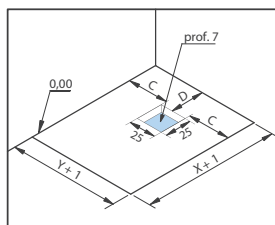
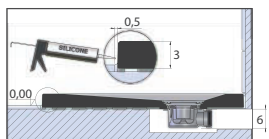
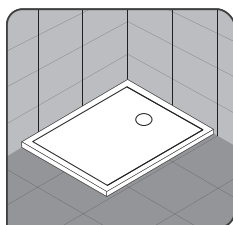

Vorbereitung montage

Ingebouwd met in hoogte verstelbare poten

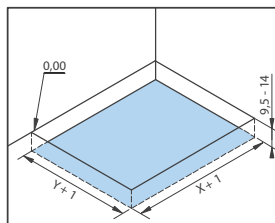
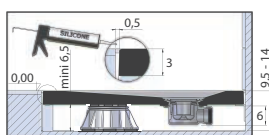

Vorbereitung montage

Ingebouwd zonder in hoogte verstelbare poten

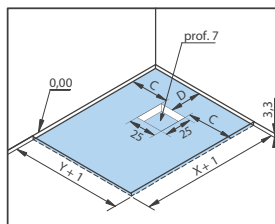
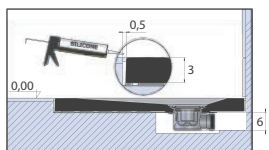
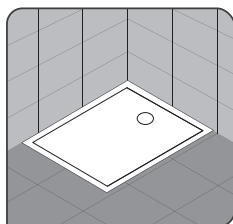

Vorbereitung montage



# DE

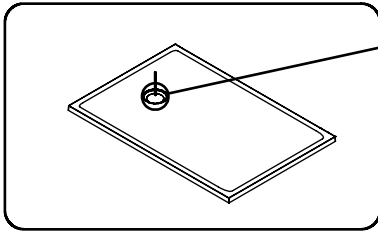

Position für den Ablauf anzeichnen und vormontieren.

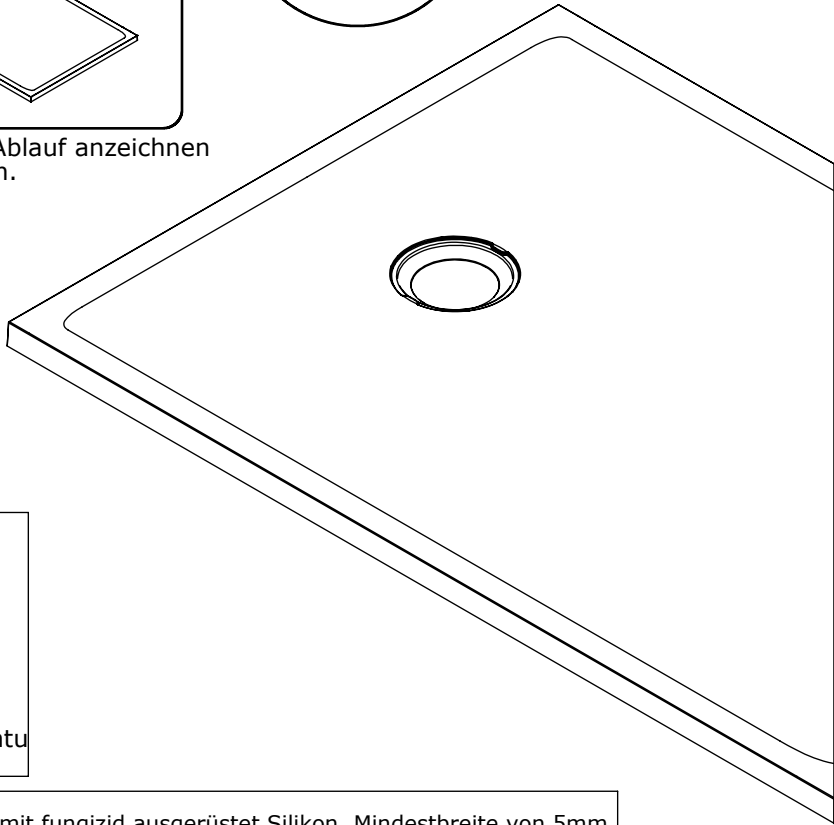
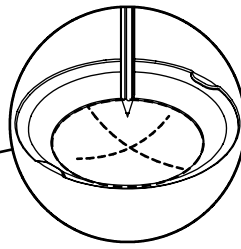

Wandanschlüsse umlaufend mit Wannensrandabdichtung  
gesehen.

- ① - Fugenabschluss mit fungizid ausgerüstet Silikon, Mindestbreite von 5mm
- ② - flexible Silikonabdichtung
- ③ - Träger Element/Unterbau Silikonabdichtung
- ④ - Silikonträger
- ⑤ - Polyurethan-Klebstoff oder MS-Polymer

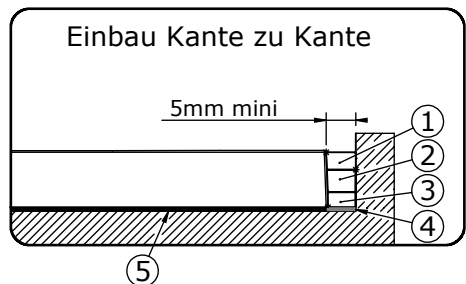
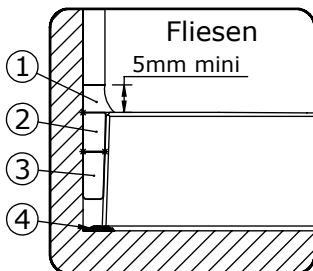





Montage eines Rohrbelüfters einplanen, wenn die Anschlussleitung als Sammelschlussleitung mehrerer Entwässerungsgegenstände geplant wurde.

Während den Installationsarbeiten auf ausreichenden Schutz gegen aggressive Mittel achten:  
Verbrennungen, Stöße, Kratzer oder Abbeizmittel...

Verwenden Sie keine säurehaltigen oder andere aggressive Entfetter.

freie Aufstellung auf Fertigfußboden

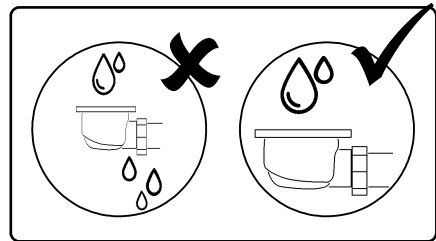
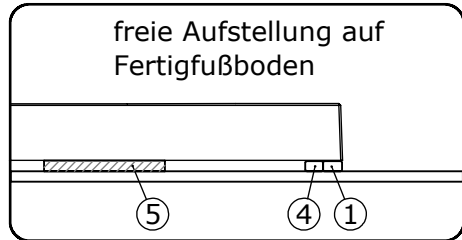

Auf festen, planen und nicht feuchten Boden achten.

einseitiger Wannenanschluß

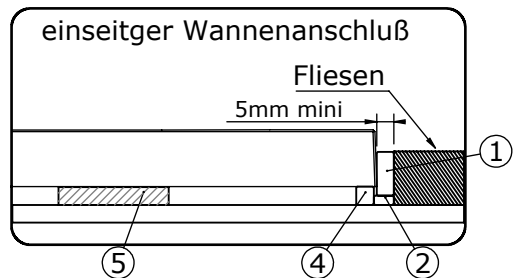

# KINEMOON EVO-INSTALLATIONSARTEN

## QUADRATISCH UND RECHTECKIG

Montage auf Fertigfußboden mit Wannenfüßen und Fliesensockel

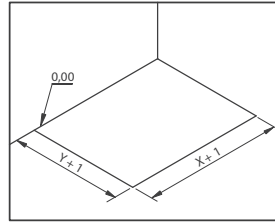
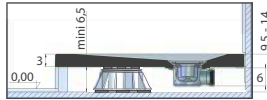
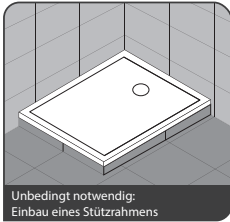

Montagevorbereitung

X	Y	C	D
80	80	27,5	12,5
90	90	32,5	12,5
100	70	22,5	12,5
100	80	27,5	12,5
100	90	32,5	12,5
120	70	22,5	12,5
120	80	27,5	12,5
120	90	32,5	12,5
140	70	22,5	12,5
140	80	27,5	12,5
140	90	32,5	12,5
160	80	27,5	22,5
160	90	32,5	22,5
170	70	22,5	22,5
180	80	27,5	22,5
180	90	32,5	22,5

Montage auf Fliesenboden aufliegend

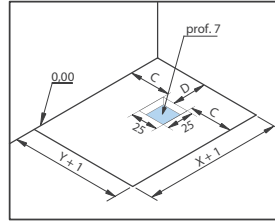
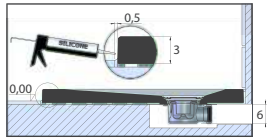
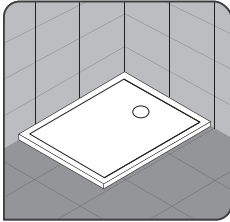

Montagevorbereitung

Bodengleiche Montage mit Wannenfüßen

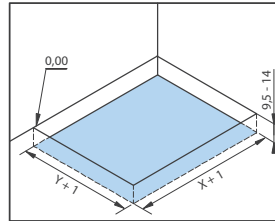
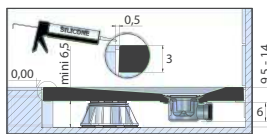

Montagevorbereitung

Bodengleiche Montage ohne Wannenfüße

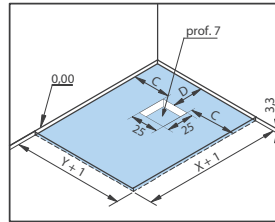
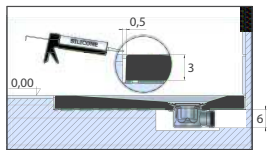
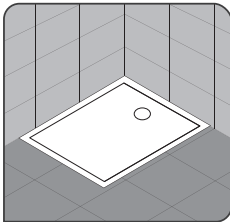

Montagevorbereitung



**FR**-Mise en place des plots de colle polyuréthane ou MS polymère

**GB**-Loading the plots glue polyurethane or MS polymer

**ES**-Ubicación de los puntos de pegamento poliuretano o polímero MS

**PT**-Localização dos pontos de cola de poliuretano ou polímero MS

**IT**-Posizione dei punti di colla poliuretanica o MS polimero

**NL**-Brenge de polyurethaan lijm of MS polymeer aan op de juiste plaats

**DE**-Bringen Sie den Polyurethan-/MS-Polymere-Kleber auf

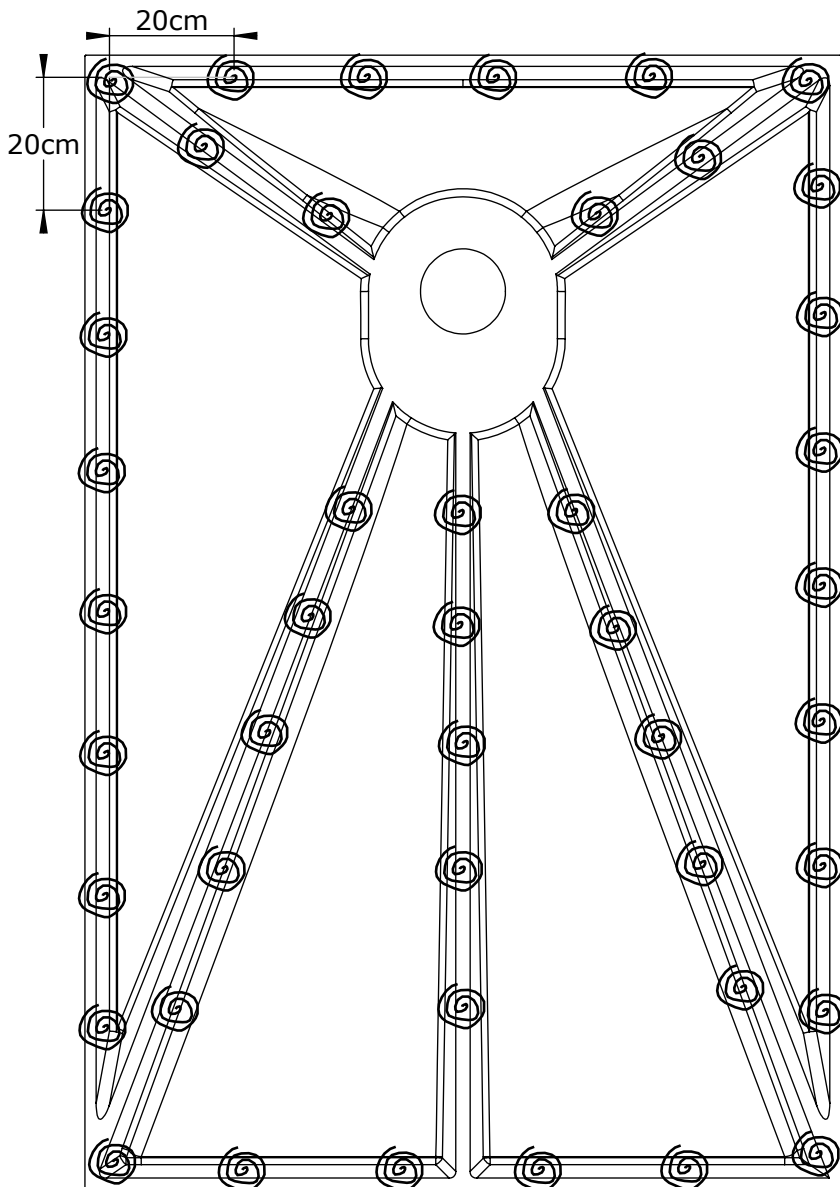



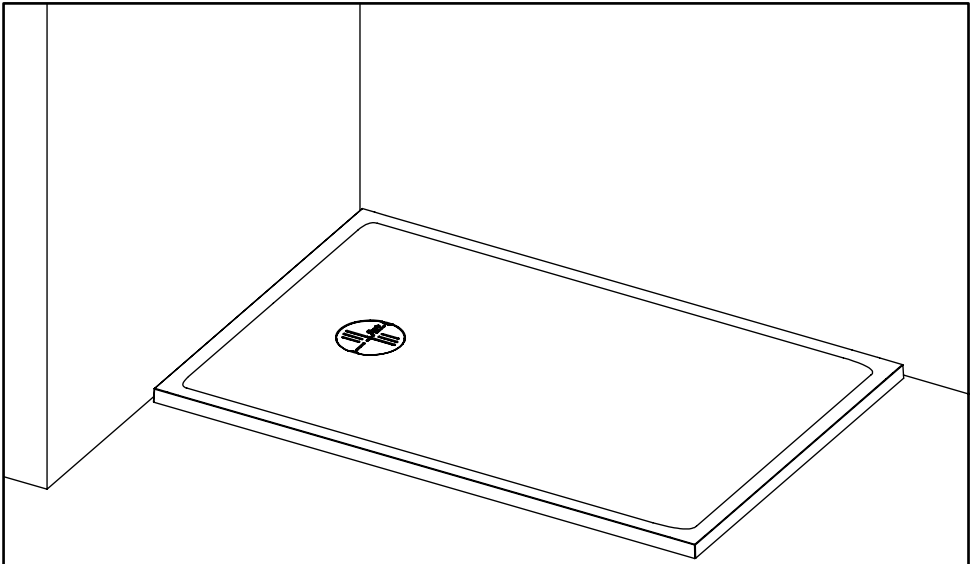

24h



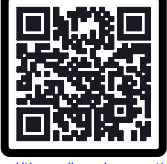

<p><b>FR</b></p> <p>Bon de garantie</p> <p><b>SCANEZ MOI</b></p>  <p><a href="http://tiny.cc/bon-de-garantie-fr">http://tiny.cc/bon-de-garantie-fr</a></p>	<p><b>GB</b></p> <p>Guarantee</p> <p><b>SCAN ME</b></p>  <p><a href="http://tiny.cc/bon-de-garantie-gb">http://tiny.cc/bon-de-garantie-gb</a></p>
<p><b>DE</b></p> <p>Garantiekarte</p> <p><b>SCAN MICH</b></p>  <p><a href="http://tiny.cc/bon-de-garantie-de">http://tiny.cc/bon-de-garantie-de</a></p>	<p><b>NL</b></p> <p>Garantievoorwaarden</p> <p><b>SCAN MIJ</b></p>  <p><a href="http://tiny.cc/bon-de-garantie-nl">http://tiny.cc/bon-de-garantie-nl</a></p>
<p><b>ES</b></p> <p>Garantía</p> <p><b>ESCANÉAME</b></p>  <p><a href="http://tiny.cc/bon-de-garantie-es">http://tiny.cc/bon-de-garantie-es</a></p>	<p><b>IT</b></p> <p>Garanzia</p> <p><b>SCANSIONAMI</b></p>  <p><a href="http://tiny.cc/bon-de-garantie-it">http://tiny.cc/bon-de-garantie-it</a></p>
<p><b>PT</b></p> <p>Garantia</p> <p><b>ESCANEEI-ME</b></p>  <p><a href="http://tiny.cc/bon-de-garantie-pt">http://tiny.cc/bon-de-garantie-pt</a></p>	<p><b>CH</b></p> <p>Garantiekarte</p> <p><b>SCAN MICH</b></p>  <p><a href="http://tiny.cc/bon-de-garantie-ch">http://tiny.cc/bon-de-garantie-ch</a></p>
<p><b>BE</b></p> <p>Garantievoorwaarden</p> <p><b>SCAN MIJ</b></p>  <p><a href="http://tiny.cc/bon-de-garantie-be">http://tiny.cc/bon-de-garantie-be</a></p>	<p><b>AT</b></p> <p>Garantiekarte</p> <p><b>SCAN MICH</b></p>  <p><a href="http://tiny.cc/bon-de-garantie-at">http://tiny.cc/bon-de-garantie-at</a></p>



# Kinedo

**FR**

Conseils  
d'entretien

SCANEZ MOI



<http://tiny.cc/conseils-entretien-fr>

**GB**

Maintenance  
instructions

SCAN ME



<http://tiny.cc/conseils-entretien-gb>

**DE**

Wartungstipps

SCAN MICH



<http://tiny.cc/conseils-entretien-de>

**NL**

Onderhoudstips

SCAN MIJ



<http://tiny.cc/conseils-entretien-nl>

**ES**

Consejos de  
mantenimiento

ESCANÉAME



<http://tiny.cc/conseils-entretien-es>

**IT**

Consigli per la  
manutenzione

SCANSIONAMI



<http://tiny.cc/conseils-entretien-it>

**PT**

Dicas de  
manutenção

ESCANEEI-ME



<http://tiny.cc/conseils-entretien-pt>

**CH**

Wartungstipps

SCAN MICH



<http://tiny.cc/conseils-entretien-ch>

**BE**

Onderhoudstips

SCAN MICH



<http://tiny.cc/conseils-entretien-be>

**AT**

Wartungstipps

SCAN MICH



<http://tiny.cc/conseils-entretien-at>



## SERVICE APRÈS-VENTE AFTER-SALES SERVICE

### FRANCE

+33 (0)2 40 21 29 45

### UK

+44 020 8842 0033

### IRELAND

+353 04697 33102

### DEUTSCHLAND

+49 (0) 6074 / 30928 0

### ITALIA

+39 02 30559420

### ÖSTEREICH

+43 1 710 60 70

### SUISSE/SCHWEIZ

+41 (01) 748 17 44

### ESPAÑA

+34 93 544 60 76

### NEDERLAND

+31 475 487 100

### BELGIQUE/BELGIË

+31 475 487 100

### РОССИЯ

+7 495 258-29-51

### PORTUGAL

+351 219 112 785



AQUAPRODUCTION, Site industriel,  
F - 44680 Chaumes-en-Retz

24

EN 14527 - CL2

Aptitude au nettoyage :

satisfaisant

Durabilité :

satisfaisant